



Operation & Installation Manual

BEARING REPEATER COMPASS

NGC-519



NOTICE TO USERS

- Thanks for purchasing this product NGC-519 Bearing Repeater Compass.
- The copyright of this manual is owned by the manufacturer, NEW SUNRISE CO., LTD (NSR). Prior written permission is required for copying or reproducing the manual or any part of the manual.
- NSR reserves the right of continuous improvement on products, both in software and in hardware, without any prior notice.
- NSR will assume no responsibility for the damage caused by improper use or modification of the product or claims of loss of profit by a third party.
- NSR does not make any representations or warranties (implied or otherwise) regarding the accuracy and completeness of this document and shall in no event be liable for any loss of profit or any commercial damage, including but not limited to special, incidental, consequential, or other damage.
- Please read this manual carefully to ensure proper use before installation and use of the product.
- Please keep the manual for your future reference.

MODIFY RECORD

No	Modify by	Date	Paragraph	Version	Reason
1	Q/A	2025/12/08		01	First edition
2	Q/A	2026/01/21	All	02	Some modification

SAFETY INSTRUCTIONS FOR THE OPERATOR

	<p>Warning Keep away from heat sources or direct sunshine. For the safety of the ship, it is prohibited to interrupt or arbitrarily the power supply to the compass during navigation.</p>
	<p>Prohibition Don't open the equipment. Don't disassemble or try to modify the equipment.</p>
	<p>Dangerous Turn off the power immediately when smoke or fire is emitted.</p>

SAFETY INSTRUCTIONS FOR THE INSTALLER



	<p>Warning Connect the earthing cord to the ship's body. Observe the compass safe distance to prevent deviation of an onboard magnetic compass.</p>
	<p>Prohibited Don't open the equipment. Only authorized or qualified personnel should install the equipment. Don't disassemble or try to modify the equipment.</p>
	<p>Dangerous Turn off the power at the power distribution board before installation.</p>

TABLE OF CONTENTS

1. PRODUCT OVERVIEW	1
1.1 Product Features.....	1
1.2 Equipment List	2
2. INSTALLATION AND OPERATION	3
2.1 Installation	3
2.2 Basic Operation	3
2.2.1 Startup indication	3
2.2.2 Self-check	4
2.2.3 Enter the normal working condition	4
2.2.4 Brightness adjustment	4
2.2.5 Close the compass	4
2.3 Settings and Calibration.....	4
2.3.1 Manually start self-check	4
2.3.2 Enter the setting mode	5
2.3.3 Check mode	5
2.3.4 Calibration mode	6
2.3.5 Scan mode	6
2.3.6 Exit the setting mode	6
3. MAINTENANCE AND REPAIR	7
4. TECHNICAL SPECIFICATIONS	8
APPENDIX I DATA FORMAT	9
APPENDIX II INSTALLATION DRAWINGS.....	11

1. PRODUCT OVERVIEW

1.1 Product Features

NGC-519 is a bearing repeater compass. After receiving the heading information from the compass (FOG/GYRO/magnetic compass/GNSS Compass), it can be used to display the heading and bearing of the ship.



The main features of NGC-519 are:

- Compass card and digital tube are both supported.
- Could be fitted with an azimuth reading device (NGC-519A).
- A gimbal mechanism is provided to enable the compass card to be held horizontally against the ship's motion.
- IP56 for use on an open deck.
- Resolution 0.1°.
- A button for dimming is provided to read the compass card at all times.
- A highlight lubber line to indicate the ship's heading.
- Multiple protocols are supported for heading information.

1.2 Equipment List

Model		Description
Standard	NGC-519	Bearing Repeater Compass
Options	NGC-519A	Azimuth Reading Device
	NGC-519B	Wall Mounting Bracket
	NGC-519J	Junction Box
	NGC-519S	Floor-Standing Mounting Bracket

2. INSTALLATION AND OPERATION

2.1 Installation

There is one data interface (IEC 61162-1/NMEA 0183) for receiving heading information. The parameters for this interface of RS422:

- baud rate: 4800bps
- 1 start bit
- 8 data bits
- no polarity check
- 1 stop bit

The data formats THS, HDT, HDG and HDM are all supported automatically. For details, refer to Appendix I.

For the connection with the compass, for example:

NGC-519 Repeater Compass Unit		NGC-512 Interface Unit of NGC-50X0	
PIN NO.	DESCRIPTION	PIN NO.	DESCRIPTION
Green	RX-	31	TX-
White	RX+	32	TX+
Black	GND (24V-)	33	GND
Red	DC24V (24V+)	34	24V

2.2 Basic Operation

When the equipment is powered on, it will automatically perform a self-check. After the self-check is completed, it will indicate the heading information.

2.2.1 Startup indication



: The power supply is on, perform a self-check.

2.2.2 Self-check

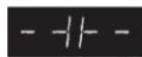

: After the self-check, the automatic calibration is matched. At the beginning, the compass card slowly rotates, stops at a certain position and the 000.0 position, and then enters the normal working state, indicating the heading of the ship.

Note: After automatic calibration and matching, the compass card reading should be basically consistent with the digital display reading.



: If this symbol appears, it indicates: self-check, automatic matching correction failed.

Err 1: The set signal was not received within 30 seconds.

Err 2: Adjustment button is on.

2.2.3 Enter the normal working condition



: After automatic matching correction, enter the normal operation.



: If this symbol appears, it indicates that no effective heading signal was received within 3s.

2.2.4 Brightness adjustment



Press  or  button to adjust the brightness of the digital display and the compass card.

2.2.5 Close the compass

Disconnect the power supply.



2.3 Settings and Calibration

2.3.1 Manually start self-check

Press the buttons   together to start the self-check. When the compass card stops at a specific position, the self-check is complete.

Note: After the automatic self-check, the compass card should be basically consistent with the digital display reading.

2.3.2 Enter the setting mode

Press the buttons   together and hold for more than 5 seconds until the  appears. Then release the buttons.

Press  or  button to select setting items:

 (CHEC): Check mode.





 ([-|-]): Calibration mode.

 (Scan): Dynamic scan mode.





 (Quit): Exit the setting mode.

Then press the buttons   together to select the item.

2.3.3 Check mode







Select check mode . Then press the buttons   together to enter the check mode: the dial returns to 000.0, and the digital display shows 000.0. Press  or  button will increase or decrease the indicated step distance by 0.1 degrees. When keeping pressing the up/down buttons, the compass card will keep rotating. Releasing the button to stop. Press these two buttons together to set. Check if the digital display and dial reading change in sync. If the deviation exceeds 0.2 degrees, return to calibration mode to adjust.

2.3.4 Calibration mode





Select Calibration mode . Then press the buttons   together to enter the calibration mode. Use  or  button to adjust the compass card until it matches the digital display.

Press these two buttons together to confirm the calibration of the compass card. After calibration, enter Check mode to verify calibration results and ensure digital display changes in sync with dial readings.

2.3.5 Scan mode

Select scan mode . Then press the buttons   together to enter the scan mode. After the compass card turns to its specific position, the digital display starts at 000.0 and rotates back and forth continuously in a 5-degree advance and 3-degree retreat manner to check if there is any step loss during the scanning process. If a lost step is detected, the scan results will be shown: . Press the buttons   together to exit the scan mode. The compass will return to normal operation after 5s.

2.3.6 Exit the setting mode

In the setting mode, press  or  button until the  appears. Then press the buttons   together to exit the setting mode. After exiting, the compass will enter automatic correction matching mode.

3. MAINTENANCE AND REPAIR

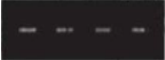
Display	Probable Reason	Remedy
	Mistakes in sentence	Check input sentences. Refer to Appendix I.
	Connection error	Check the connection. Refer to Section 2.1.
	Heading is invalid	Check the heading source.

Note: NGC-519 cannot be repaired and needs to be replaced entirely.

4. TECHNICAL SPECIFICATIONS

No.	Item	Description
1	Mechanical parameters	Resolution: 0.1° Reading accuracy: 0.05° IP grade: IP56
2	Electrical parameters	Voltage: 24V Power Consumption: About 6W Interface: RS422, 4800bps (IEC61162-1, 2024)
3	Ambient temperature	-25°C to + 70°C
4	Compass Safe Distance	Standard: 0.45m, Steering: 0.25m
5	Size	Ø254 x 170 mm Refer to the appendix drawings.
6	Weight	About 6kg

APPENDIX I DATA FORMAT

HDT - Heading true

```
$--HDT,x.x,T*hh<CR><LF>
  |  |
  +-+-----1
```

1. Heading, degrees true

Note: "--" could be HE/HC/GP

HDG - Heading, deviation and variation

```
$--HDG,x.x,x.x,a,x.x,a*hh<CR><LF>
  |  |  |
  |  |  +-+-----3
  |  +-+-----2
  +-+-----1
```

1. Magnetic sensor heading, degrees

2. Magnetic deviation, degrees E/W

3. Magnetic variation, degrees E/W

Note: Talker ID "--" should be HC

THS - True heading and status

```
$--THS,x.x,a*hh<CR><LF>
  |  |
  |  +-+-----2
  +-+-----1
```

1. Heading, degrees true

2. Mode indicator, A: Autonomous, E: Estimated, M: Manual input, S: Simulator mode,
N: Data not valid

Note: "--" could be HE/HC/GP

HDM - Heading, Magnetic

\$--HDM,x.x,M*hh<CR><LF>

| |
| +-----2
+-----1

1. Heading, degrees

2. Magnetic

Note: "--" should be HC

APPENDIX II INSTALLATION DRAWINGS

Drawing No.	Description
NGC519-ID-001	NGC-519 BEARING REPEATER SIZE&MOUNTING DRAWING
NGC519-ID-002	NGC-519J JUNCTION BOX SIZE DRAWING
NGC519-ID-003	NGC-519A AZIMUTH READING DEVICE SIZE&MOUNTING DRAWING

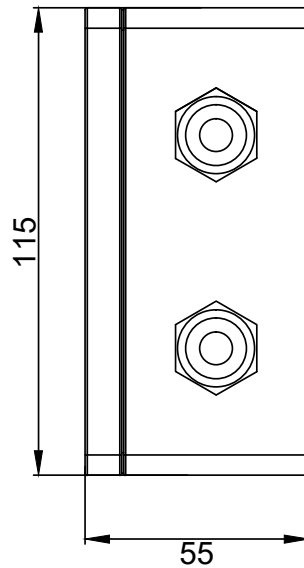
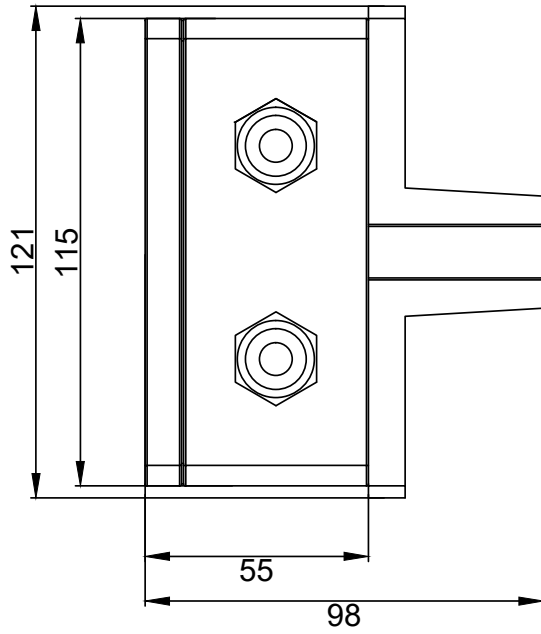
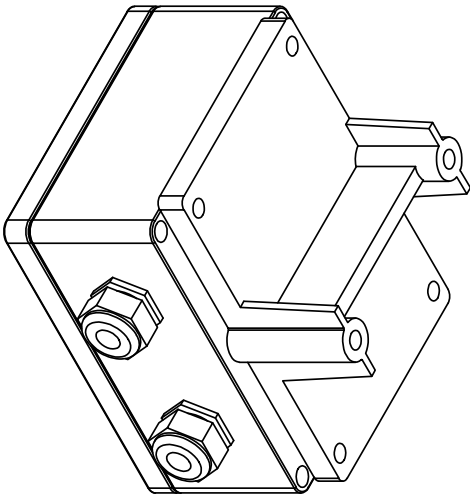
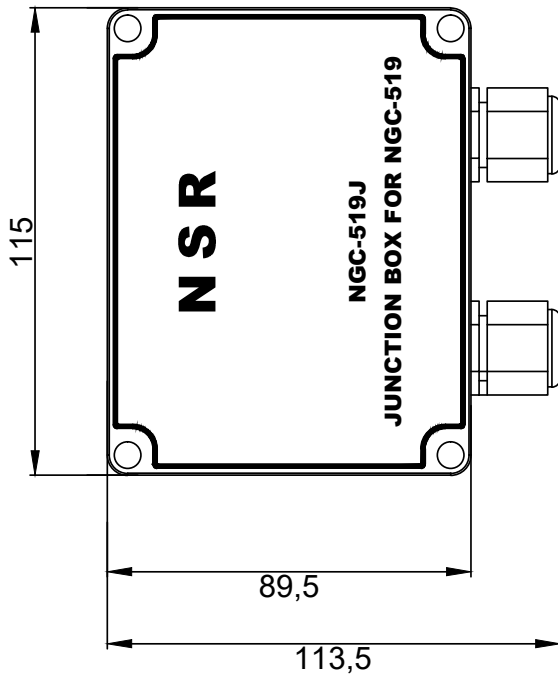

NO.	DATE	REVISION & DESCRIPTION	CHECKED	SIGNATURE

APPLICATION: NGC-519J JUNCTION BOX SIZE DRAWING									
DATE	ITER	SCALE	UNIT	PROJ. NO.	DATE	SITE	HA		
APPROVAL	CHECKED	DRAWING	DATE						
NSR NEW SUNRISE CO., LTD.									
<small>NSR ID: NGC519-ID-002</small>									

(Optional)

NO.	DATE	REVISION & DESCRIPTION	CHECKED	SIGNATURE

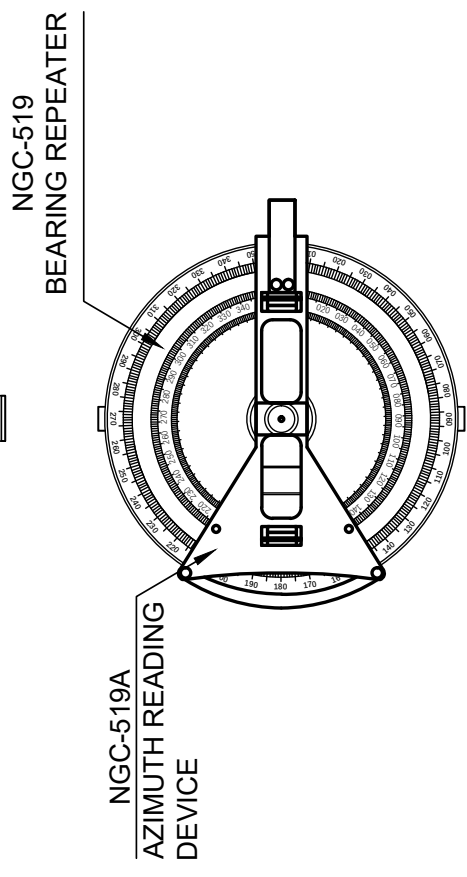
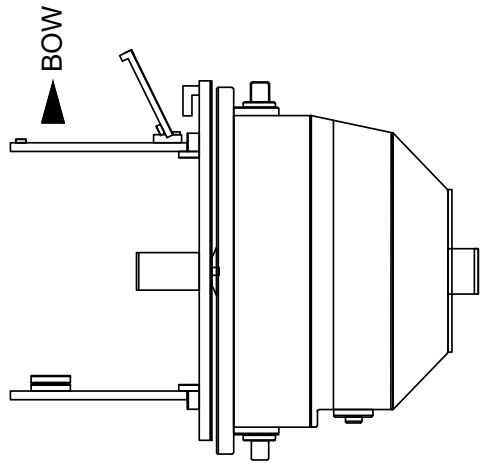
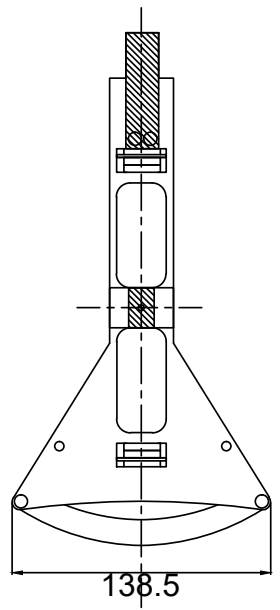
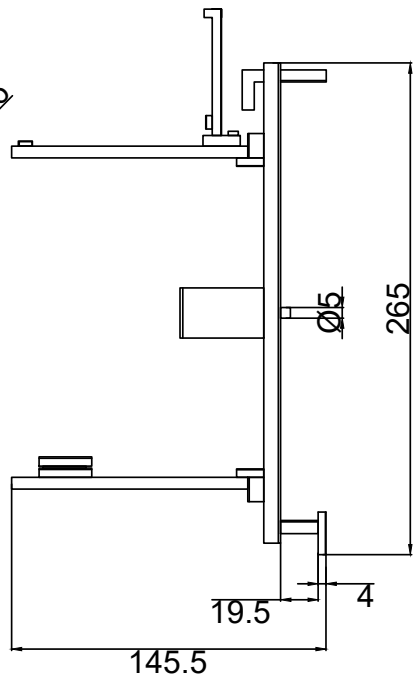
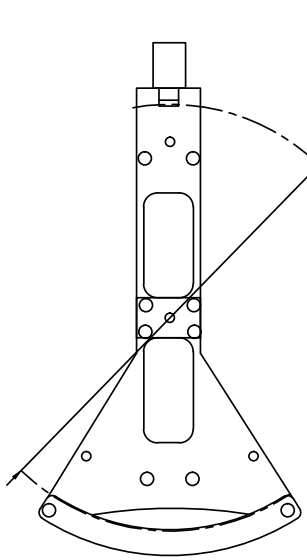

APPLICATION: NGC-519A AZIMUTH READING DEVICE SIZE & MOUNTING DRAWING									
DATE	ITER	SCALE	UNIT	PROJ.	DESIGN	CHECKED	DATE	SITE	NO.
DRAWING NO.: NGC519-ID-003									

(Optional)

Copyright by NEW SUNRISE CO., LTD. (NSR)

www.nsrmarine.com

info@nsrmarine.com

January, 2026