



USER MANUAL

AIS/GNSS PLOTTER

NSI-1000 MKD

NAB-1000 MKD

NES-3010/ NES-3010G

SAFETY NOTICE

Thank you for using our NES-3010(G) AIS/GNSS Plotter.

Before installation and use, please read this Manual carefully in order to use properly and keep it fully functioned. This Manual is supplied with the equipment, so please keep it properly for future operation and maintenance reference.

Don't try to modify the equipment

This equipment is a complicated system, so any modification or replacement of any part may need to adjust the equipment accordingly, otherwise the performance may be affected.

Use the equipment properly

Set and use the equipment by following this manual. This equipment is a device to assist navigation only. Users shouldn't rely on this device to make judgment, so as to avoid the unnecessary damage when sailing or fishing.

Power Supply

This equipment is powered by DC24V.

When used with NSR AIS, the equipment is connected to AIS with the connection cable supplied.

When used as an independent GNSS potter, the equipment can be powered with built-in power supply circuits. Make sure about proper voltage and positive/negative terminal before connecting. Wrong connection may damage the equipment.

IMPORTANT NOTICE

1. Charts in this Plotter is only for navigation reference. Users cannot rely on it without using paper charts.
2. The Manual may not match the equipment exactly due to different setting or software version, which will not affect the performance.
3. NSR will assume no responsibility for the damage caused by improper use or modification of the equipment or claims of loss of profit by a third party.

MODIFY RECORD

No.	Modify by	Date	Paragraph	Version	Reason
1	Q/A	2022/03/08		01	First edition

TABLE OF CONTENTS

1. GENERAL	1
2. EQUIPMENT DESCRIPTION	2
2.1 MAIN PANEL	2
2.2 FUNCTION KEYS.....	2
2.3 POWER ON/OFF.....	3
2.4 BRIGHTNESS ADJUSTMENT	4
2.5 MAIN MENUS	4
3. NAVIGATION OPERATION	7
3.1 ABOUT CHART/MAP	7
3.1.1 BASIC FUNCTIONS	8
3.1.2 CHART BROWSE AND HELP	8
3.1.3 CHART MODE	9
3.1.4 KEY ELEMENTS ON CHART/MAP	10
3.1.5 OPERATION ON CHART/MAP MENU	12
3.2 WAY POINT	12
3.2.1 ADD WAY POINT	13
3.2.2 GOTO WAY POINT	15
3.2.3 EDIT WAY POINT.....	15
3.2.4 DELETE WAY POINT	15
3.3 ROUTE	16
3.3.1 NEW ROUTE	17
3.3.2 EDIT ROUTE.....	20
3.3.3 DELETE ROUTE	21
3.3.4 ROUTE NAVIGATION.....	22
3.4 NAVIGATION MODES	25
4. AIS OPERATION	26
4.1 ABOUT AIS	26
4.1.1 WHAT'S AIS	26
4.1.2 SHIP'S DATA.....	27
4.2 AIS TARGETS ON CHART/MAP	27
4.2.1 TARGET ICON.....	27
4.2.2 AIS LIST	29
4.2.3 DANGEROUS LIST	30
4.3 MENU OPERATION.....	30
4.3.1 AIS LIST	31
4.3.2 FAVORITES.....	36
4.3.3 VIEW OWN SHIP INFORMATION.....	39
4.3.4 VOYAGE DATA (NSI-1000 MKD).....	40
4.3.5 VOYAGE SETTING.....	45
4.3.6 LONGRANGE SETTING (NSI-1000 MKD)	48

4.3.7 DESTINATION LIST (NSI-1000 MKD)	50
4.3.8 AIS MESSAGE.....	52
4.3.9 AIS DIAGNOSTICS.....	58
5. SETTING	62
5.1 SYSTEM SETTING	62
5.2 SOFTWARE UPGRADE.....	65
5.3 VERSION	67
6. ADVANCED	68
6.1 COM MONITOR.....	68
6.2 I/O BAUDRATE (NSI-1000 MKD).....	69
6.3 STATIC DATA SETTING	70
6.4 FORWARDING (NSI-1000 MKD).....	73
6.5 ADVANCED SETTING (NSI-1000 MKD)	74
6.6 FACTORY SETTING	76
7. INSTALLATION	77
7.1 EQUIPMENT INSTALLATION	77
7.2 GNSS ANTENNA INSTALLATION	77
7.3 CONNECTION	77
8. MAINTENANCE	78
8.1 ROUTINE MAINTENANCE	78
8.2 TROUBLESHOOTING	78
8.3 COMMUNICATION WITH AIS TRANSPONDER.....	79
APPENDIX 1 TECHNICAL SPECIFICATIONS	80
APPENDIX 2 MENU TREE	81
APPENDIX 3 LIST OF SHIP TYPE	83
APPENDIX 4 ABBREVIATIONS	84
APPENDIX 5 INSTALLATION DRAWINGS	86

1. GENERAL

NES-3010(G) AIS/GNSS plotter is designed for vessel navigation, which can work together with AIS as an AIS MKD for NSR NSI-1000 and NAB-1000, or can also work independently as a GNSS navigator.

This equipment consists of CPU Board, 10.1' LCD display, power supply module and Interface etc. It conforms to the regulations of IMO MSC 112 (73) , IEC 60945, IEC 61108-1, IEC 61162-1 etc.

The equipment adopts high-resolution color LCD display, together with knob & touch screen operation, in Android system.

The equipment has the basic ECS navigational function, includes auto navigation, route planning, etc.

When connected with AIS as a MKD, the equipment has AIS display function, displaying AIS targets in real time and alerting for approaching vessels. AIS searching function is helpful to locate a target vessel efficiently. AIS Friend function is useful for vessel group management.

There are two models:

NO.	Models	Descriptions	Applications
1	NES-3010	Plotter for AIS A, AIS B DC24V	NSR NSI-1000 MKD NSR NAB-1000 MKD
2	NES-3010G	Standalone GNSS plotter DC24V With built-in GNSS receiver	

The system configuration (connected with AIS) is as follows:

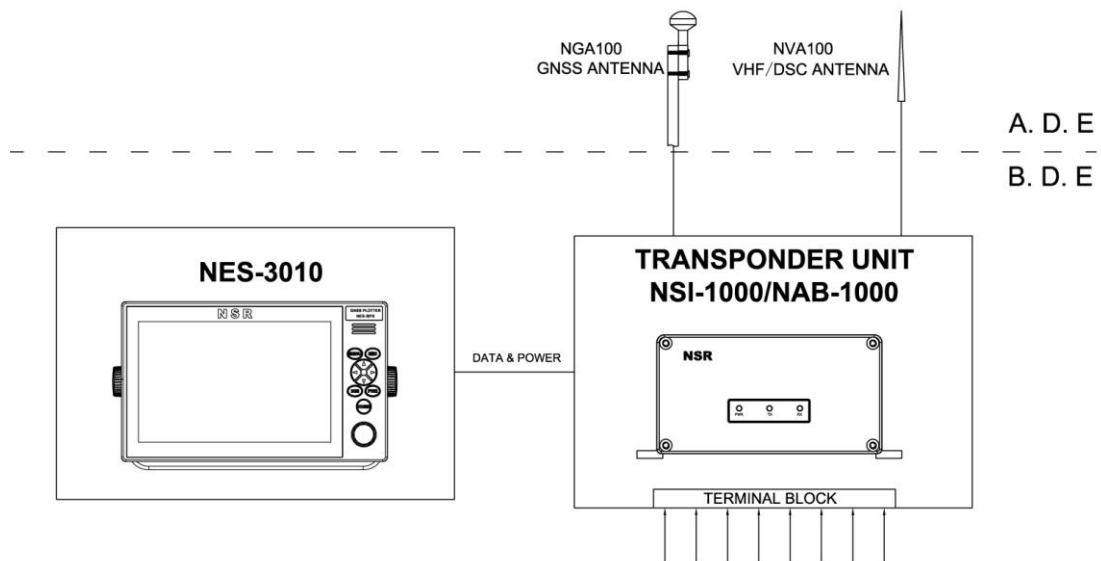





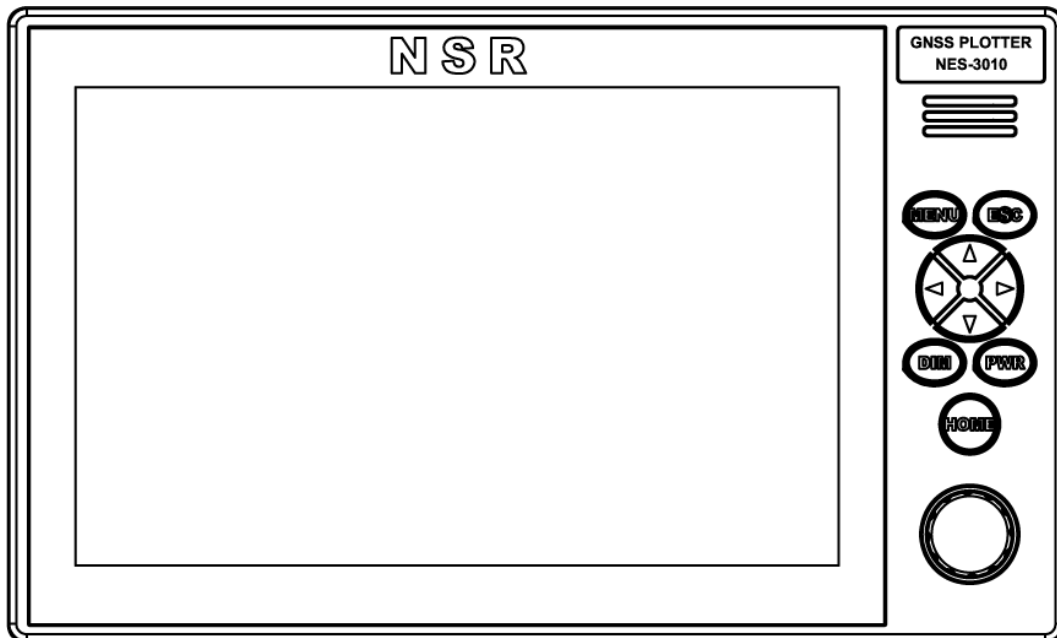

2. EQUIPMENT DESCRIPTION

2.1 MAIN PANEL



2.2 FUNCTION KEYS

The plotter can be operated by key & knob on panel or touch-screen operation.

Panel key of NES-3010(G)	Description
	Turn to select an item. Press to confirm the selection or input.
	Switch between the menu items in CHART screen.
	Cancel current task and return to Main screen; Close the menu item in CHART screen.
	Up, Down, Left, Right Key, move cursor to choose sub-menu items; Move chart/point in Chart screen.
	Brightness key to control LCD brightness.
	Power ON/OFF, Restart. To power OFF, press and hold this key for 3 seconds.
	Return to Main screen.

2.3 POWER ON/OFF

- **Power On**

Press to power on the equipment, Main screen appears (take NSI-1000 MKD as sample):

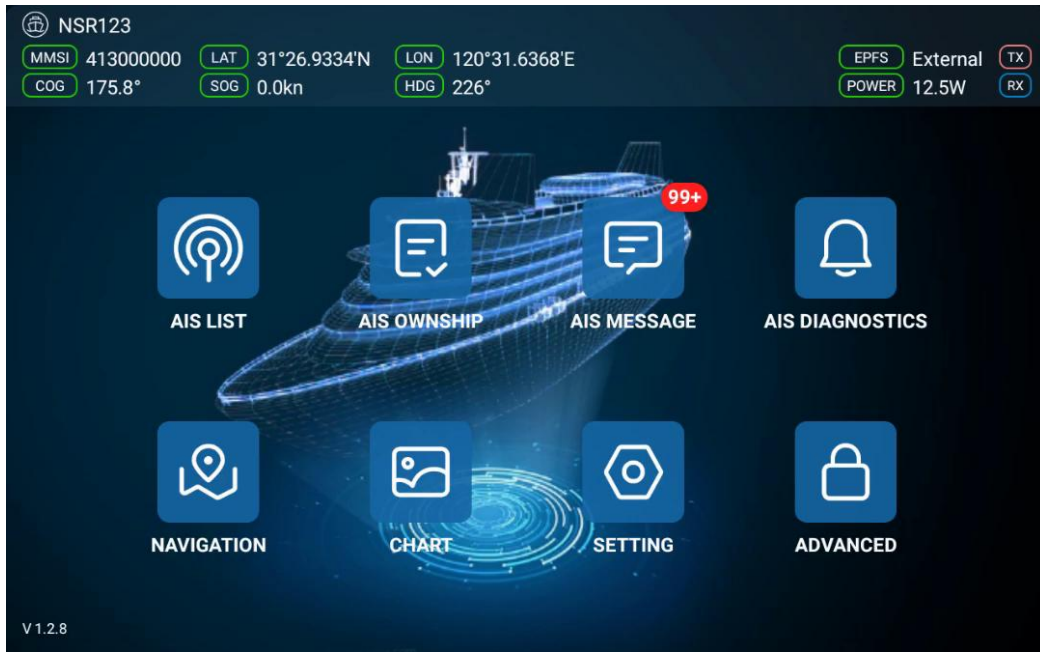

- **Power Off / Restart**

Press and hold for 3 seconds and choose **[Power off]** to power off the equipment.

If system has no response due to mis-operation etc., press for 3 seconds and choose **[Restart]** to restart the equipment.

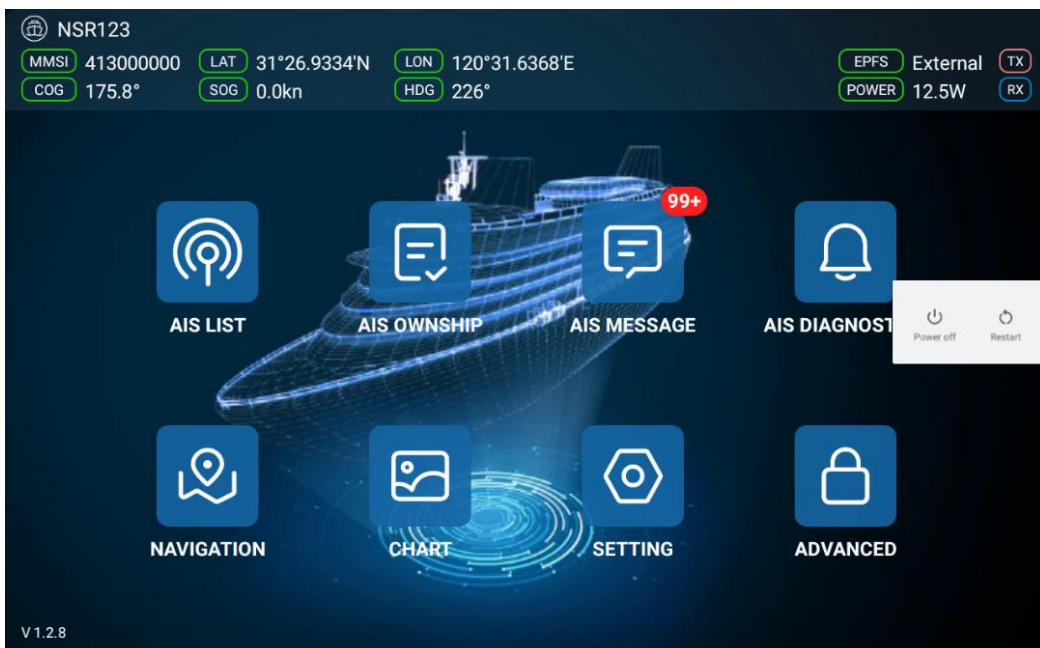

2.4 BRIGHTNESS ADJUSTMENT





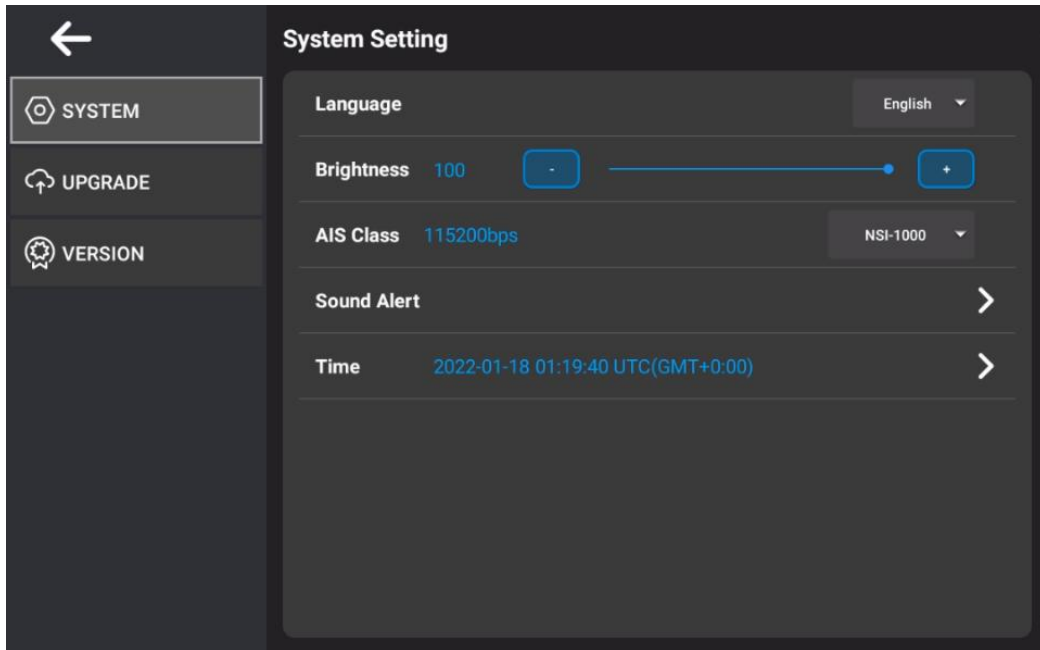



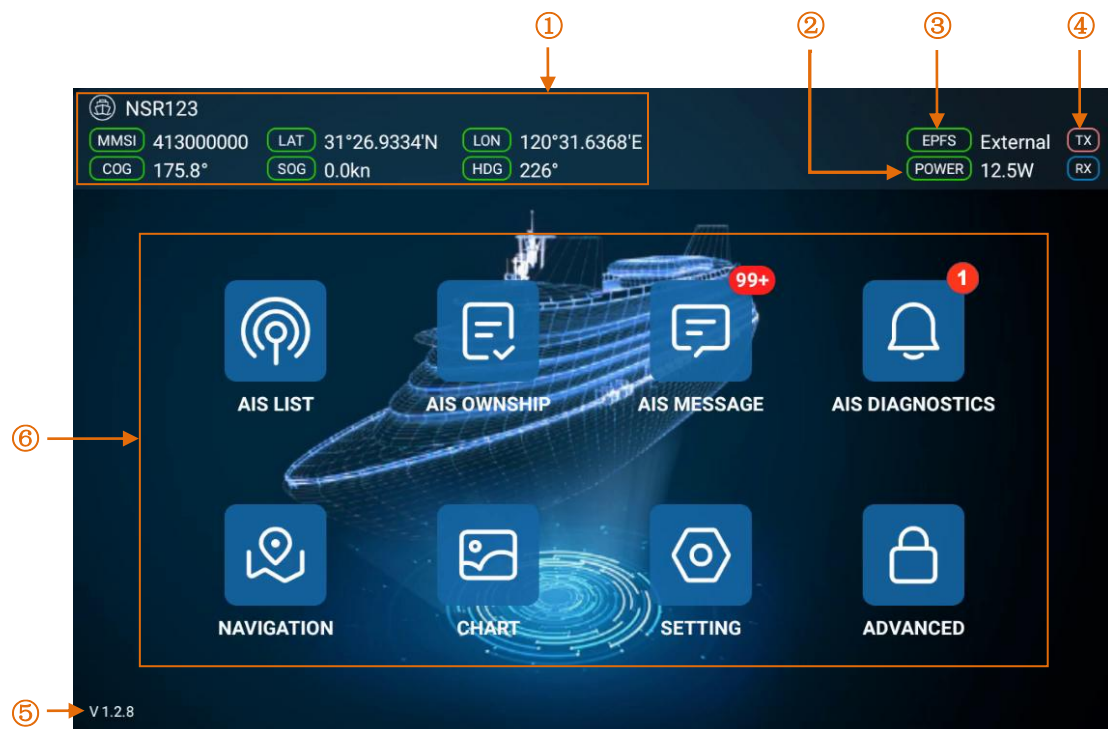













There are two ways to adjust the brightness of screen.

- ① Press **DIM** on panel to adjust the brightness, or
- ② Adjust the brightness in [SETTING]-[SYSTEM]-[Brightness]. Refer to **Section 5.1**.



2.5 MAIN MENUS



No.	Item	Symbol	Meaning
1	Own ship data		Own ship's name (For example: NSR123).
			Own ship's ID (9 digits).
			Position, latitude.
			Position, longitude.
			Course Over Ground.
			Speed Over Ground.
			Heading.
2	TX power (NSI-1000 MKD)		Current output power of NSI-1000: 12.5W/5W/ 1W/NULL.
3	EPFS (NSI-1000 MKD)		External: The external EPFS valid, regardless of internal EPFS. Internal: Only internal EPFS valid, while external EPFS invalid. No GPS: No GPS data. N/A: The plotter is not connected to NSI-1000.
4	TX/RX status	 	AIS TX/RX status. Transmitting:  , Receiving: 
5	Version	v1.2.8	MKD version, for example.
6	Function buttons		Check [AIS List] and [Favorites List]. Refer to Section 4.31 & 4.3.2 .
			Quickly view own ship status, voyage and long range setting etc. Refer to Section 4.3.3~4.3.7 .
			Messages received.  99+: The number of messages unread. New message editing and sending (NSI-1000 MKD). Refer to Section 4.3.8 .
			Alarm list, Power ON/OFF history, etc. Refer to Section 4.3.9 .  1: The number of alarms unchecked.
			Enter [NAVIGATION] screen. Refer to Section 3 .
			Chart management.
			System setting, software upgrade and version. Refer to Section 5 .
			Advanced function. Refer to Section 6 .

Note: The above screen is the example when NSR AIS NSI-1000 is connected. The following is the example when NSR AIS NAB-1000 is connected.

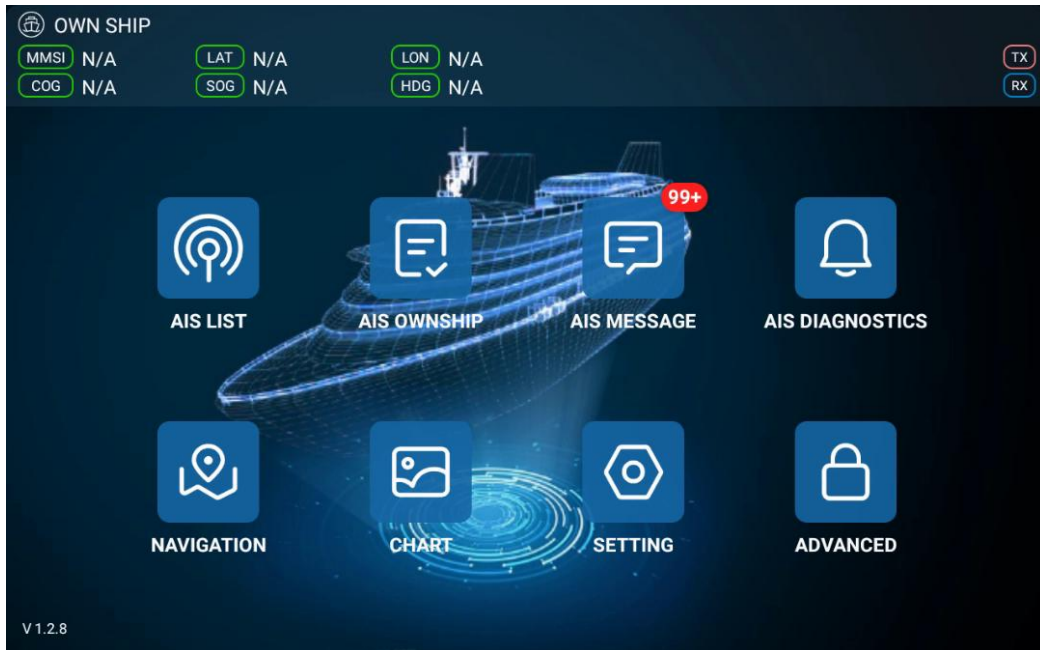









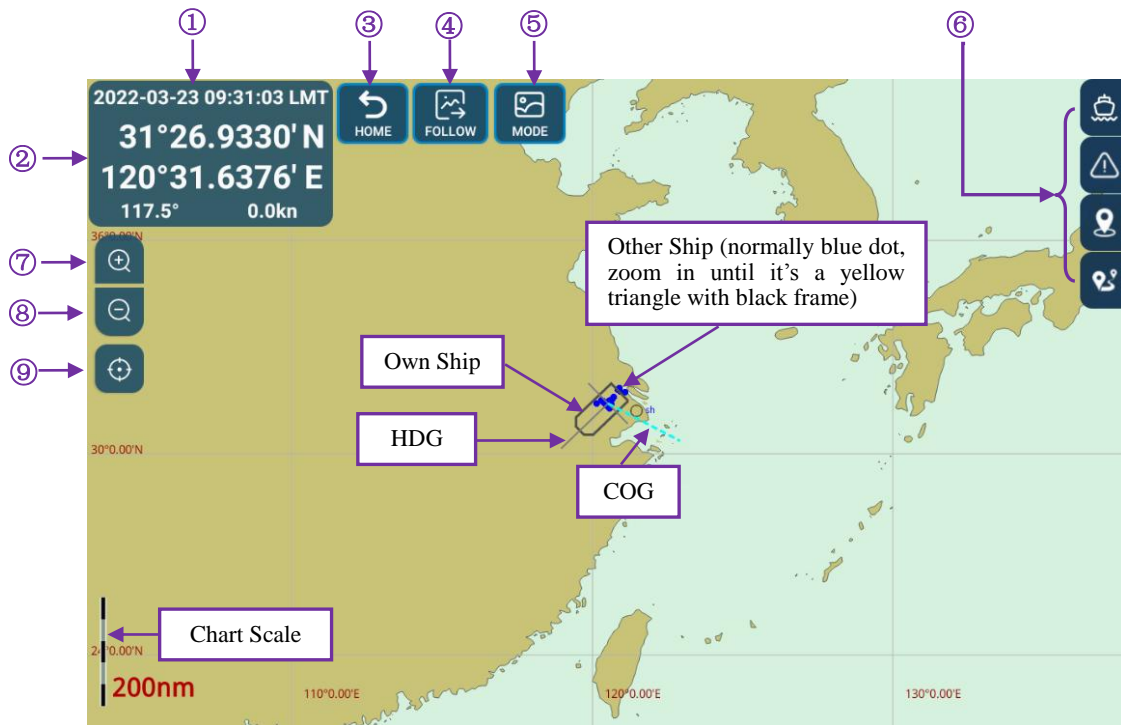

Note: Unless specified otherwise, the following description is an example of NSI-1000 MKD.

3. NAVIGATION OPERATION

3.1 ABOUT CHART/MAP

Click  on main screen, the following [NAVIGATION] screen appears:



No.	Symbol	Meaning
1		Current Date & Time (UTC / LMT).
2		Own ship information.
3		Return to Main screen.
4		Chart browse mode. Click to change as FOLLOW or FREE .
5		Chart mode setting. Refer to Section 3.1.3 .
6		Chart/Map menu buttons. Refer to Section 3.1.5 .
7		Zoom in.
8		Zoom out.
9		Centralize: Press the key to keep own ship in the centre of screen.



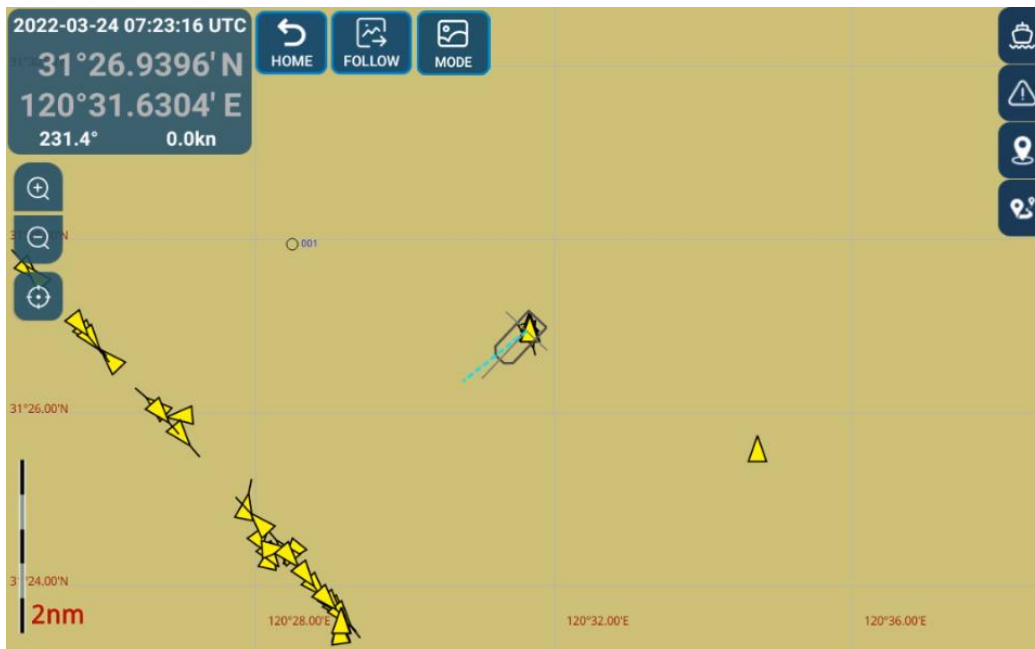



Note: The font color of latitude/longitude will turn gray while the position information is lost. The last position data will be displayed on the screen.



3.1.1 BASIC FUNCTIONS

- Display own vessel position and provide necessary information;
- Receive surrounding AIS targets;
- Marking in particular position.
- Set new Way Points;
- Plan voyage route, etc.

3.1.2 CHART BROWSE AND HELP

- **Browse Chart:** Press Up, Down, Left, Right Key (), move Cursor to browse chart.
- **Follow mode** (): Own ship will be in the centre of screen automatically after 10 seconds of inactivity.
- **Free mode** (): Own ship will not be in the centre of screen automatically. You can move the chart by your finger.
- **Zoom:** Click  key to zoom in and  key to zoom out.
- **Centralize:** Click  key to keep own vessel in the centre of screen.

3.1.3 CHART MODE



Click **MODE**, then the following **[Chart Settings]** screen appears:

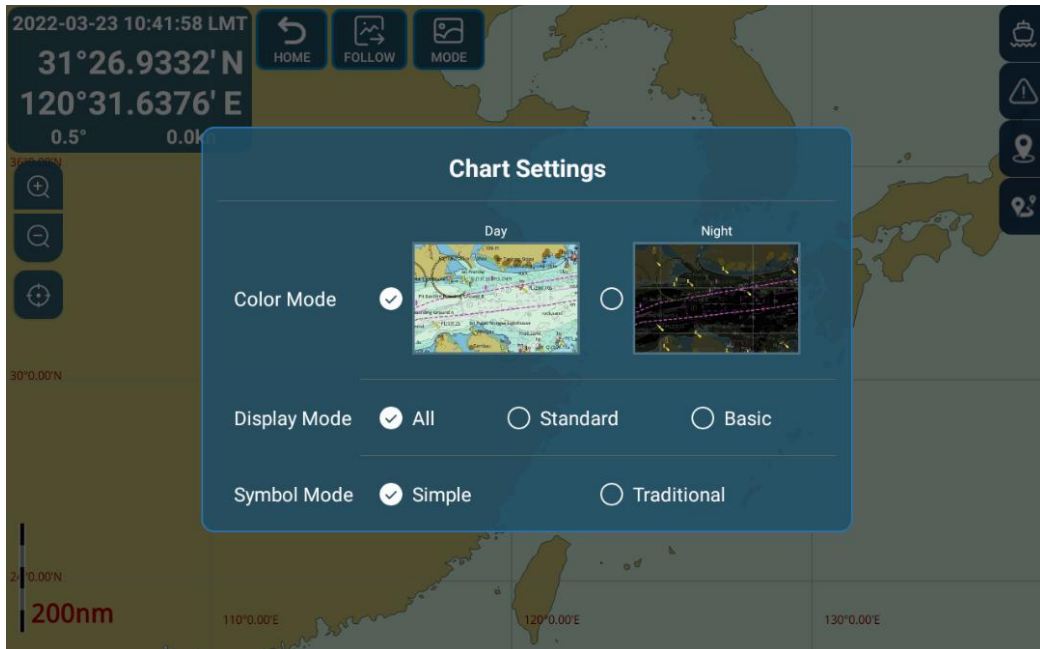

You can set **Color Mode / Display Mode / Symbol Mode**.

For example, **Night** mode is selected:

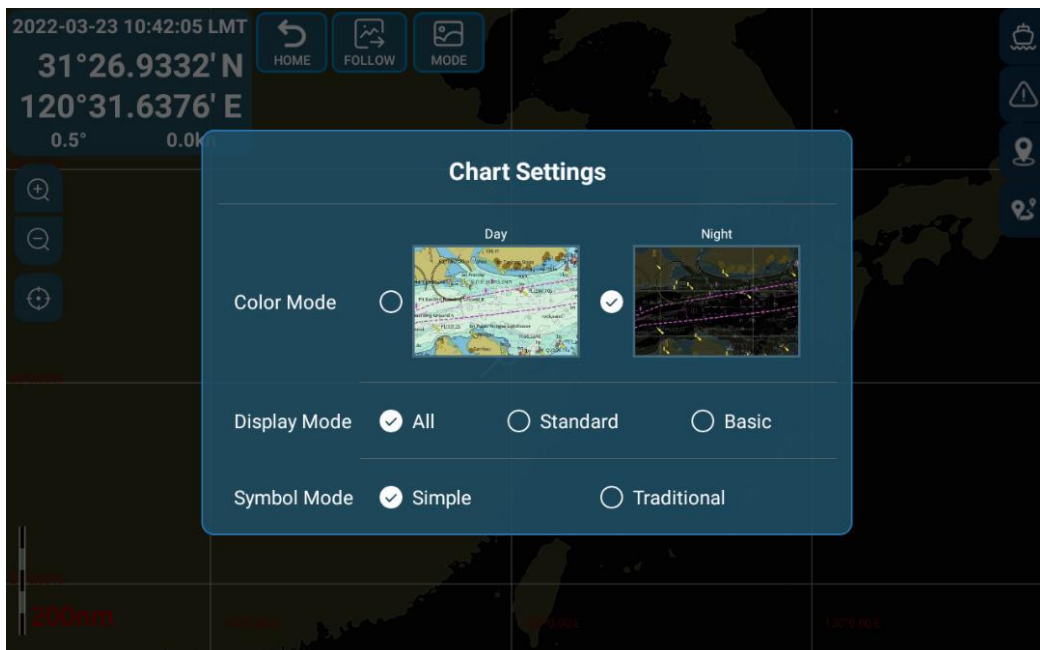

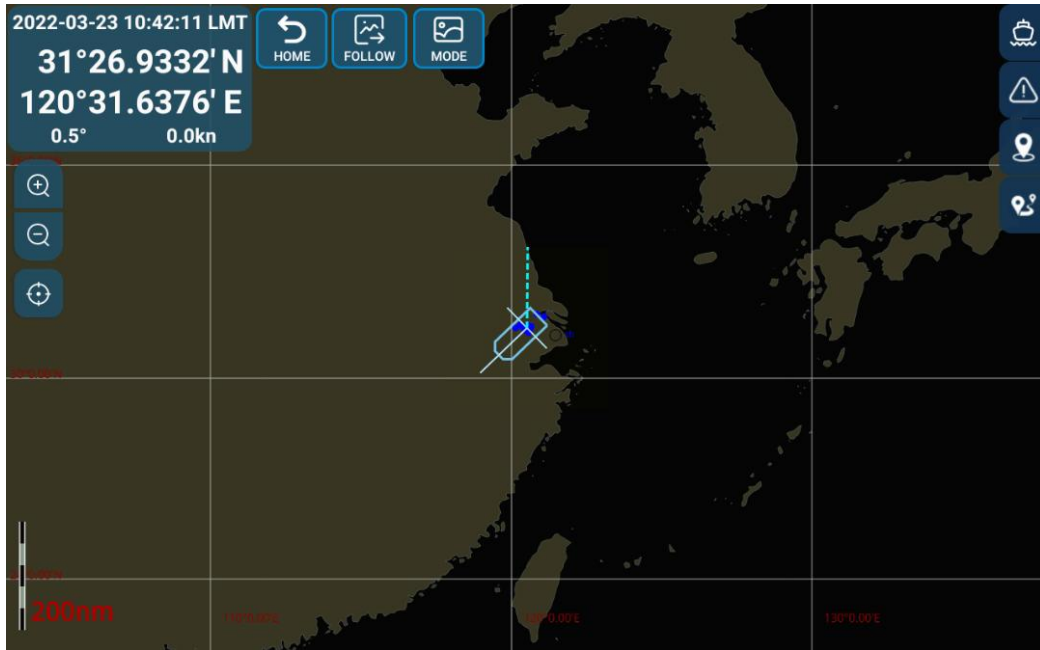





3.1.4 KEY ELEMENTS ON CHART/MAP

Click the empty area, then the following menu will appear.





-  : Press Up, Down, Left, Right key () to move the cross position.
-  : Click to go to the selected waypoint quickly. It'll draw a blue line between own ship and the waypoint as bellow. Refer to **Section 3.2.2**.

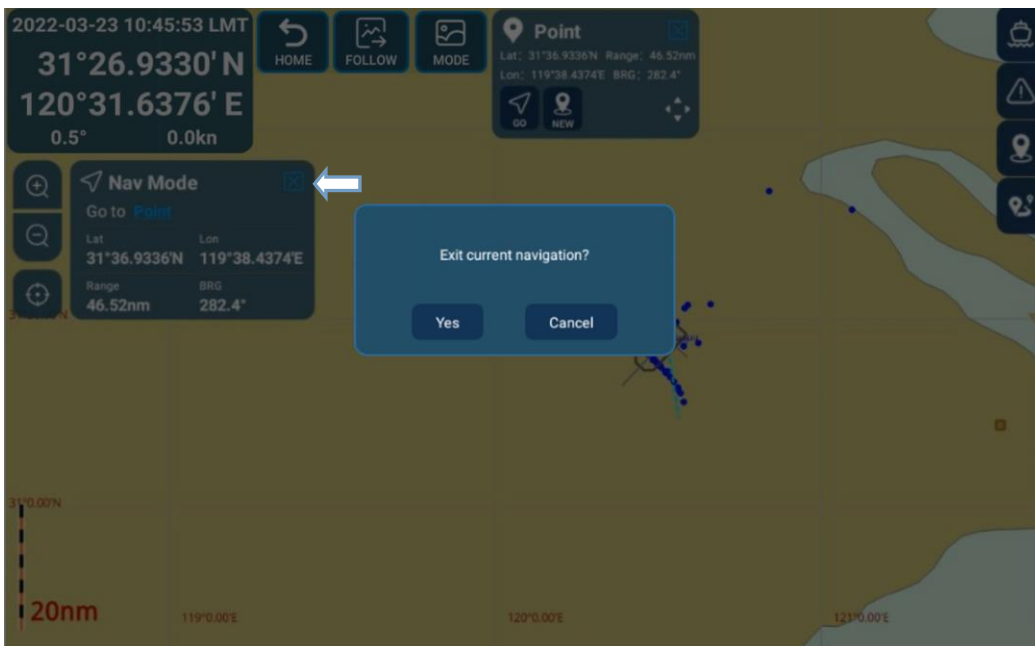

Click  and choose “Yes” in the pop-up window to exit current navigation.



-  : Click to create the selected point as a new waypoint. Refer to **Section 3.2.1**.

If current cursor pointing on AIS target, click it and then the following AIS target detailed information will appear. Click  can close the information.

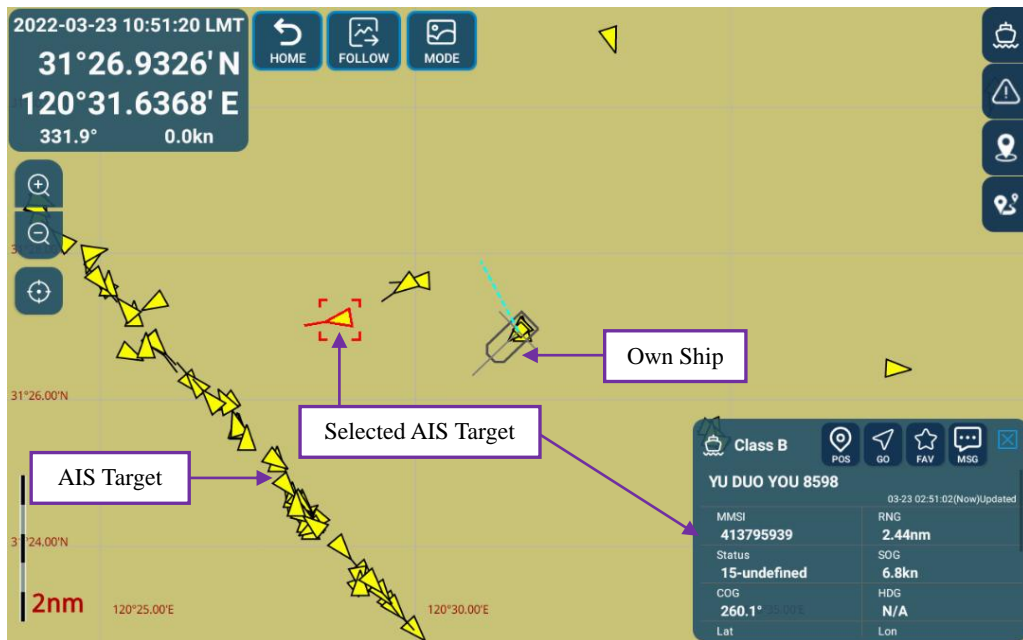

3.1.5 OPERATION ON CHART/MAP MENU

Operation on Chart/Map Menu includes:
Click each item to enter into its sub menu.

	AIS List
	Dangerous List
	Way Point
	Route

3.2 WAY POINT

Waypoints are key points on route. Normally they are turning points and important points. This equipment can keep many waypoints. The kept Points can be used for “Navigational Points” or for planning new routes.



3.2.1 ADD WAY POINT

To add way point, click  , then the “New Way Point” window is shown as below:

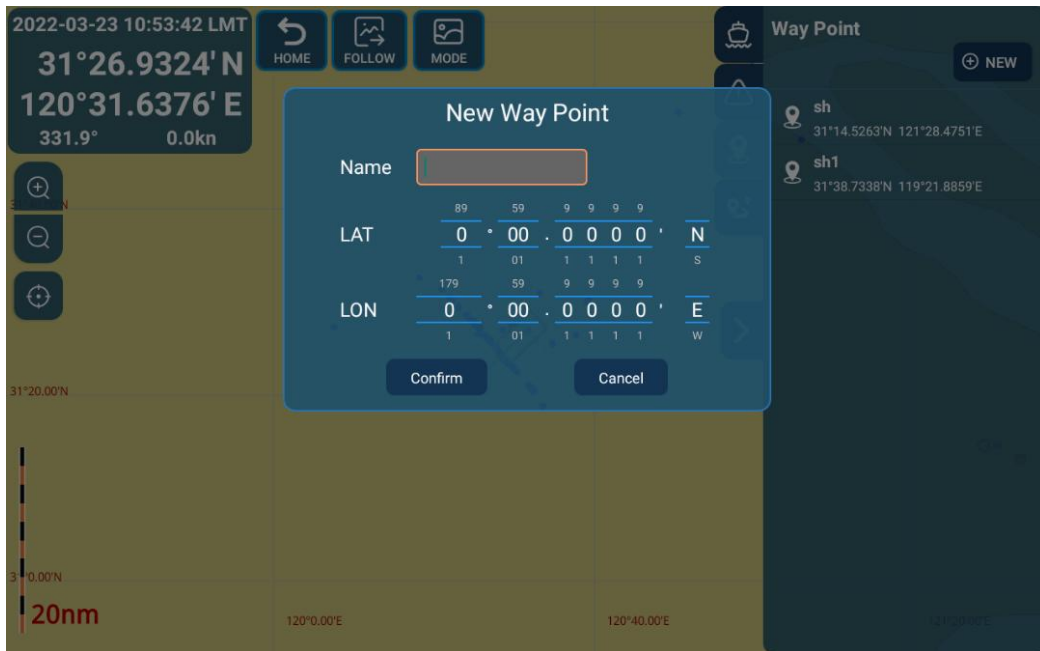

You can edit the name by the pop-up soft keypad ( to confirm). Swipe up and down to select latitude and longitude, then choose “Confirm” to add the point. If you want to switch latitude between N and S, Longitude between E and S, you can also swipe up or down to choose. **In particular, this can be used at all places where latitude and longitude need inputting.**

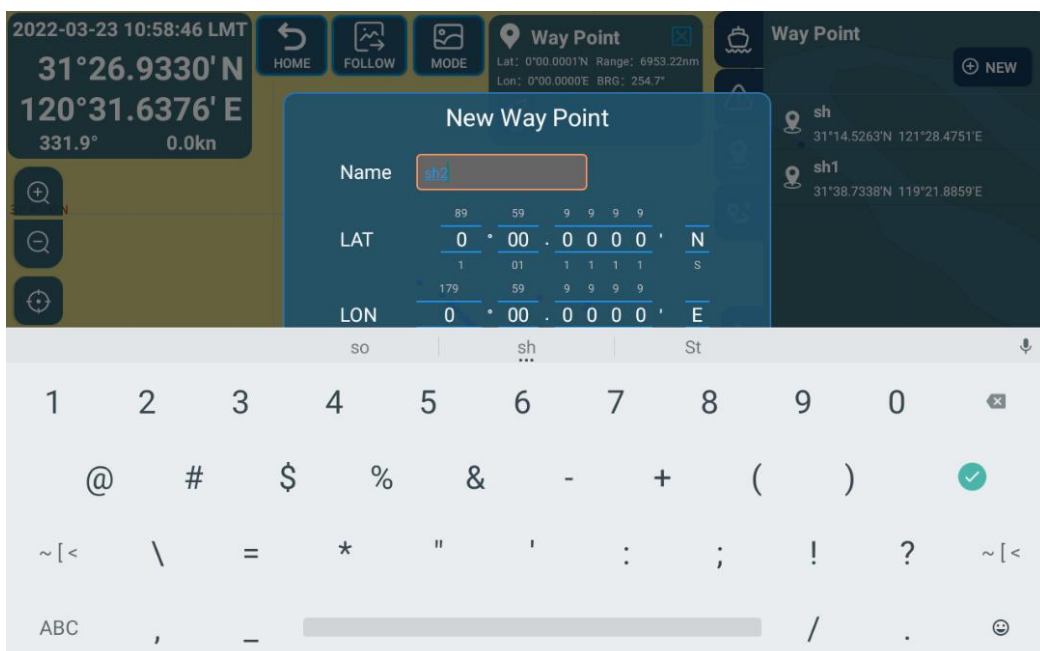



You can click to select the way point, and the latitude (**Lat**) /longitude (**Lon**) of the waypoint, then the distance (**Range**) and bearing (**BRG**) from own ship will be displayed.

Note:

Choose and press one way point until the following window appears, then you can **Go to/Edit/Delete** the way point.

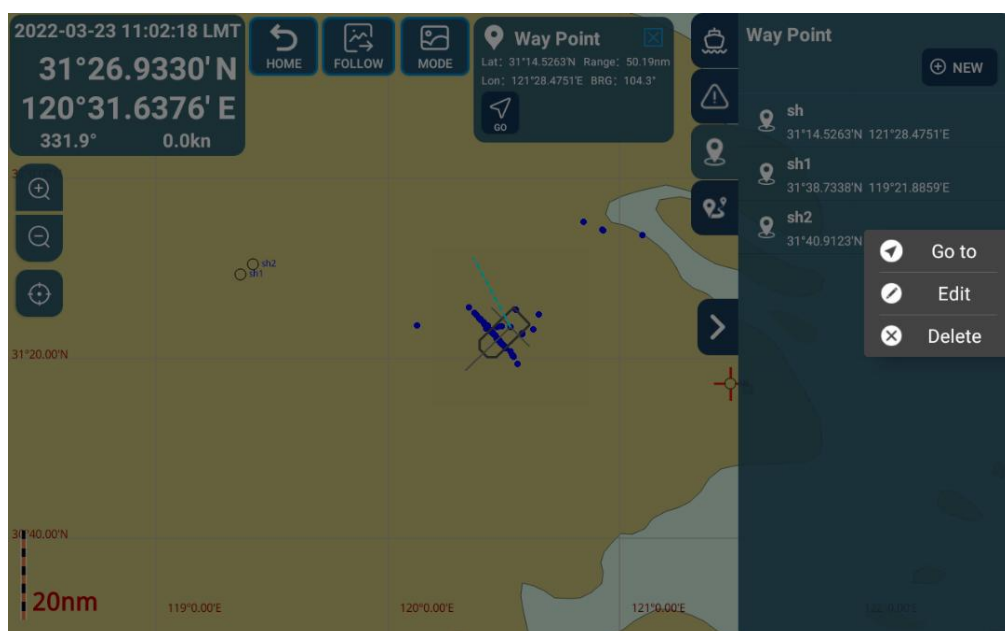

3.2.2 GOTO WAY POINT

Click . The **Nav Mode** window of Goto Way Point will be shown as below. Draw a blue line between own ship and the way point.



3.2.3 EDIT WAY POINT

Click to edit Way Point. The operation is same as **Section 3.2.1** (Add Way Point).

3.2.4 DELETE WAY POINT

Click . You can delete the way point which has been selected. The message will be shown as in the following screen. Choose “**Yes**” to delete the point, or “**Cancel**” to quit without doing anything.

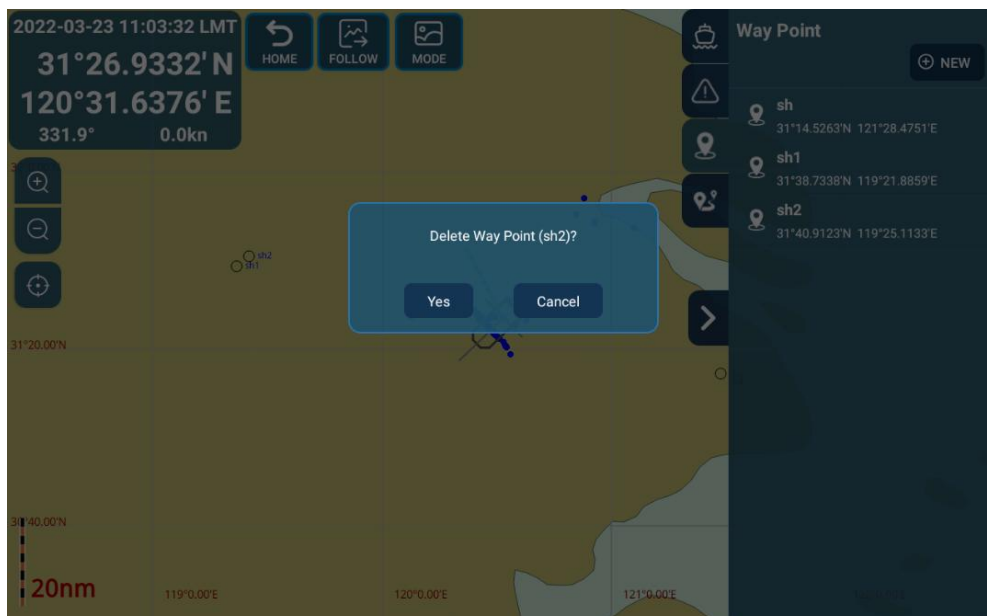

3.3 ROUTE

You can create new routes and edit these routes. After confirming the “Route” and choosing **NAV** function, vessel can be automatically navigated by following the route.



The **Route** list window displays the route name, the total number of route way points and the total mileage.

Click to choose a route from the **Route** list, and the route and **Route Preview** window will be shown as follows.



Choose and press one route until the following window appears. You can do the following operations of the route, including **Navigation/Edit/Delete** items.

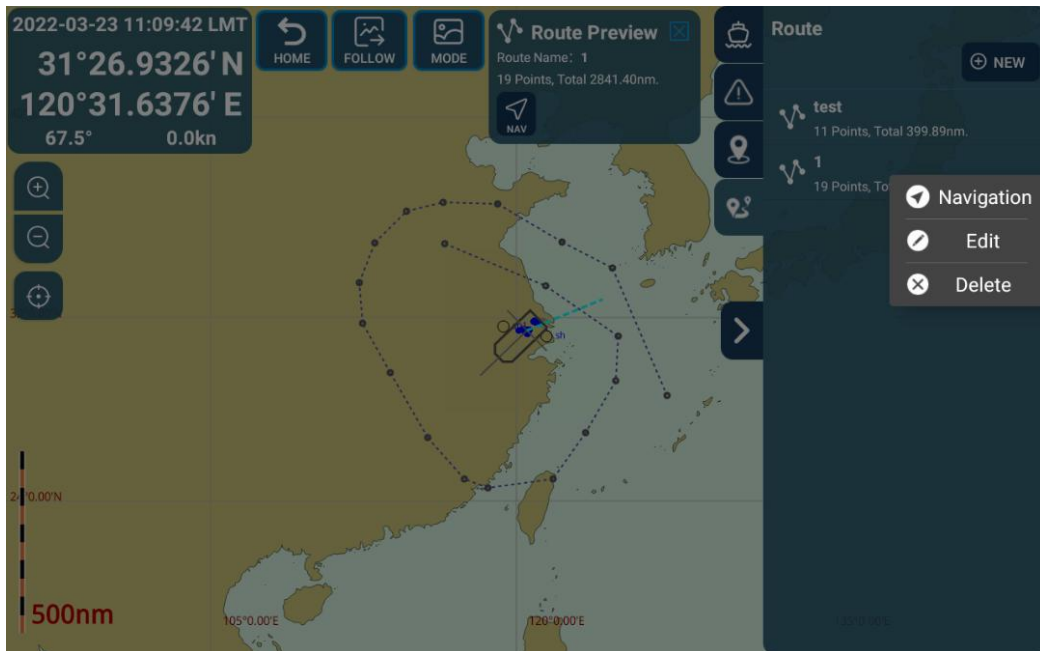

3.3.1 NEW ROUTE

- ① To create a new route, click in the **Route** list. The “**New Route**” window will be shown as below:



- ② Click the empty area to create RouteWP (way points) one by one.

Note: This will create a new empty route. The way to add/edit RouteWP (way point) is same as **Section 3.1.4, 3.2.1.**

Operations of **New Route**:

	Back to select previous RouteWP.
	Jump to select next RouteWP.
	Edit selected RouteWP.
	Delete selected RouteWP.
	Press Up, Down, Left, Right key () to adjust the position of selected RouteWP.
	Save the new route created.
	Cancel the operation of new route.

For example:

③ After all route points are set, click  to save the new route. The following screen appears:

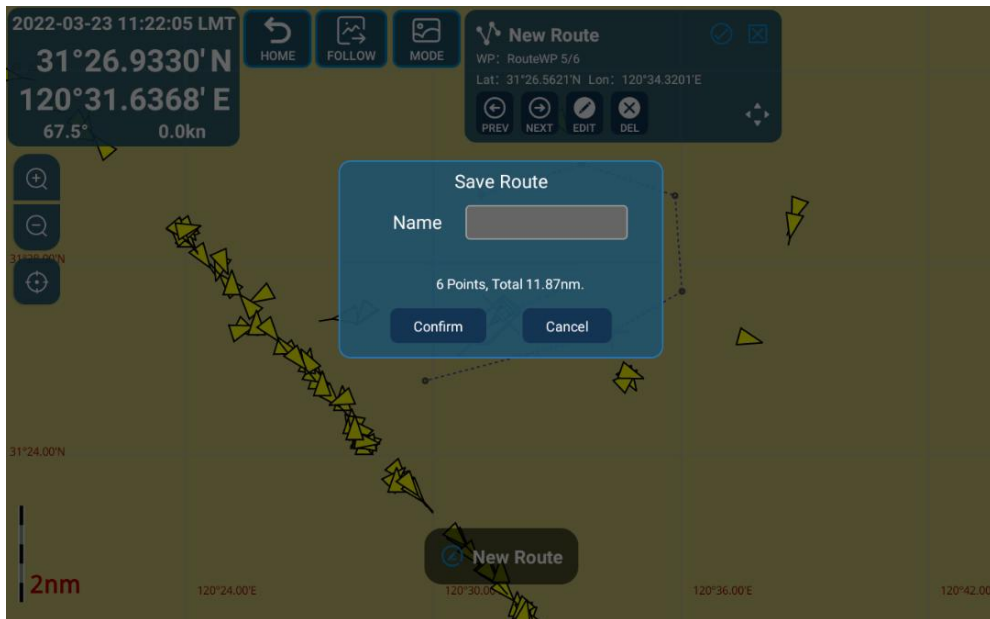

Edit the name of the route by pop-up soft keypad (for example, r011).

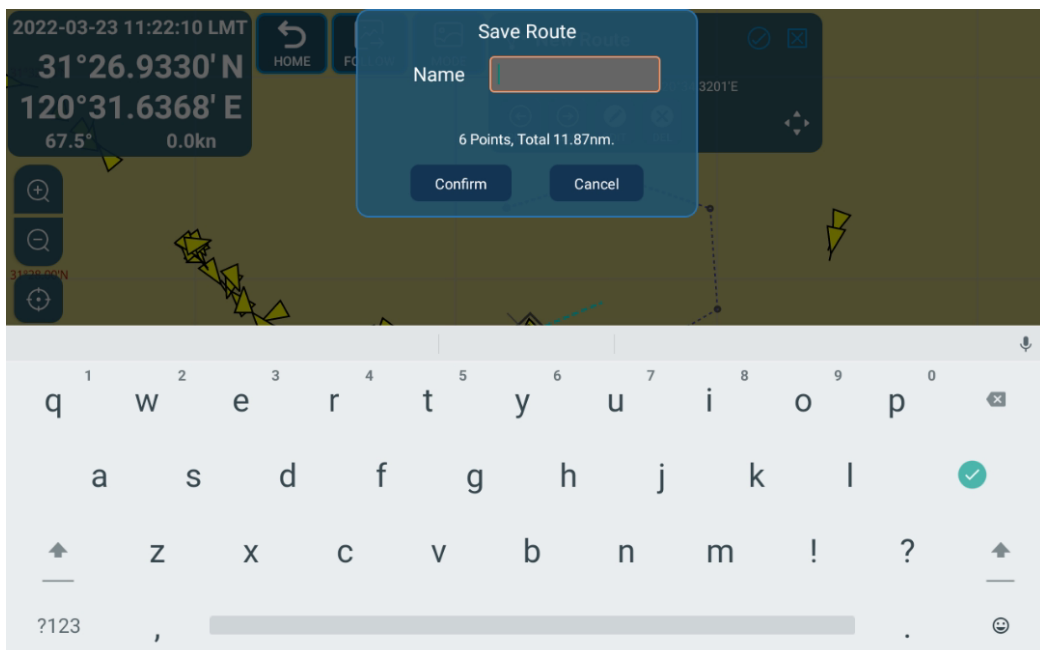

Then click “**Confirm**” to finish the operation. New route (r011) is displayed in the **Route** list as bellow:



3.3.2 EDIT ROUTE

In the **Route** list, choose and press one route until the following window appears.



Click **Edit**, then you can edit the selected route in the **Edit Route** window. For example, you can add, delete and edit any RouteWP. The operation is same as **Section 3.3.1**.



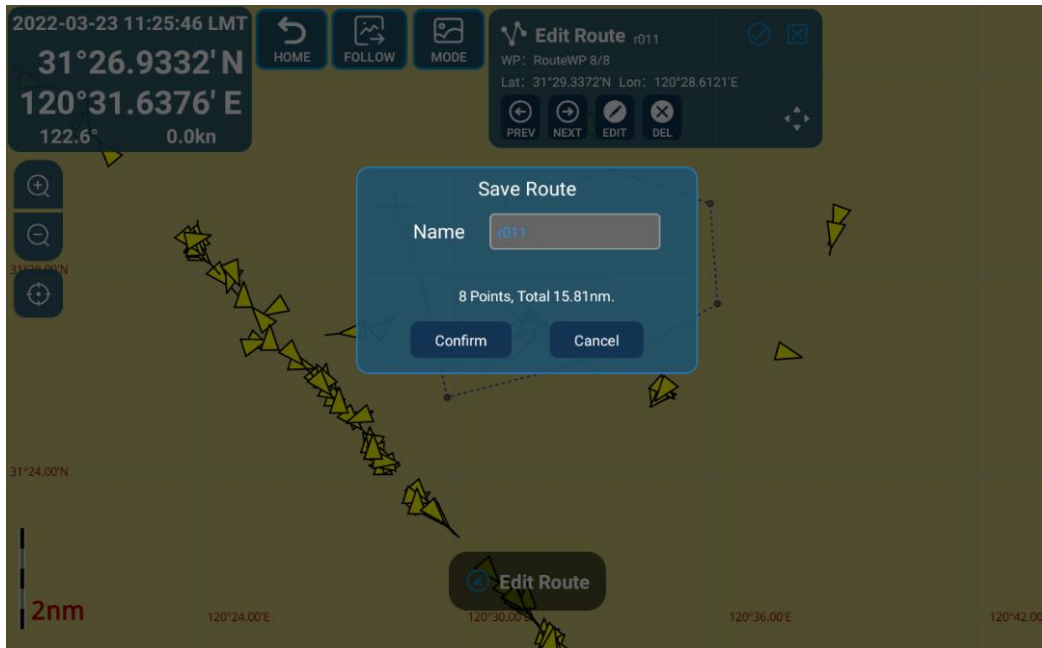

After editing, click  to save the route. You can also rename the route by pop-up soft keypad. Then click “**Confirm**” to finish the operation.

3.3.3 DELETE ROUTE

In the **Route** list, choose and press one route until the following window appears.



Click  **Delete**, you can delete the selected route. The message will be shown as in the following screen. Choose “**Yes**” to delete the route, or “**Cancel**” to quit without doing anything.



3.3.4 ROUTE NAVIGATION

In the **Route** list, choose and press one route until the following window appears.



Click **Navigation** and then you can start the navigation by the selected route. An indigo blue line is displayed between the own ship and the starting RouteWP.

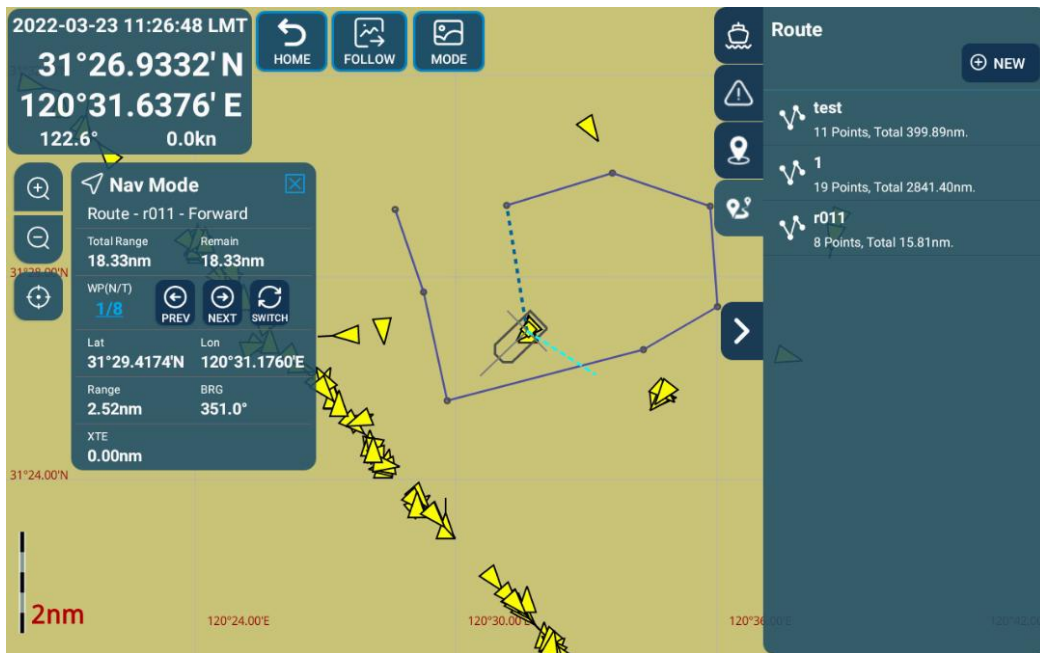





Note:

Choose one route in the **Route** list, and click  in the **Route Preview** window. You can also start the route navigation.



In **Nav Mode** window, you can check the current navigation information.

-  : Change the navigation to the previous RouteWP.
-  : Change the navigation to the next RouteWP.
-  : Change between Forward or Reversed navigation.
-  : Quit the navigation.

For example, click , skip the current 1/8 WP and go to the next 2/8 WP. The own ship will head to 2/8 WP.

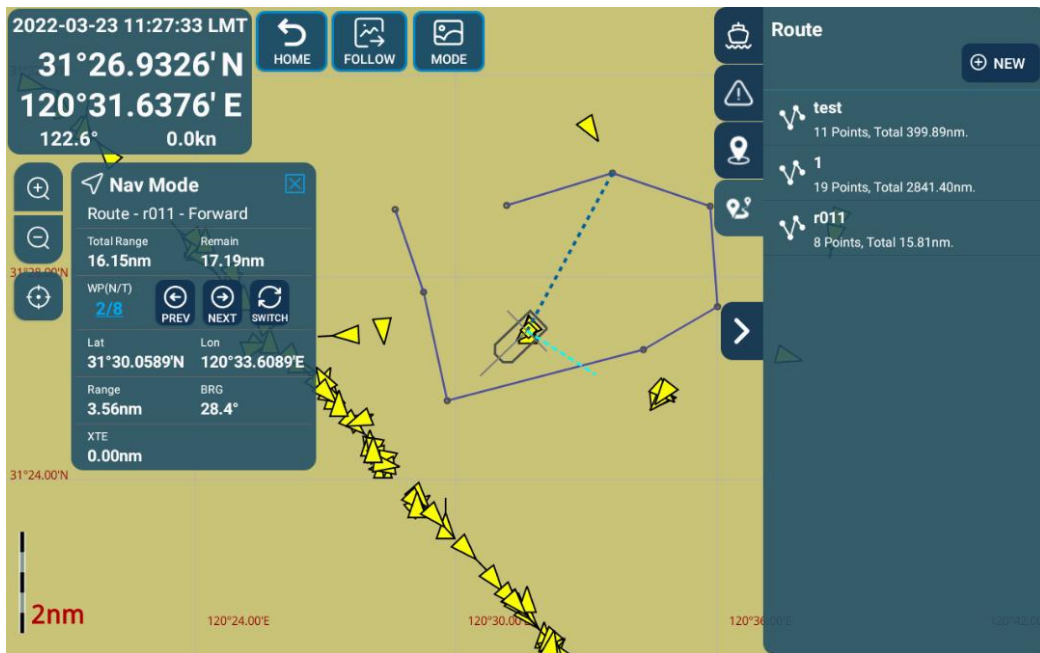

- **Forward Navigation:** Navigate from RouteWP small to large. The window is as below:



- **Reversed Navigation:** Navigate from RouteWP large to small.

Click  . You can change the Forward navigation to Reversed navigation and vice versa.



- **Cancel Navigation**

Click and choose “Yes” in the pop-up window to exit current navigation. This kind of way can be used by all kinds of navigation in the system.

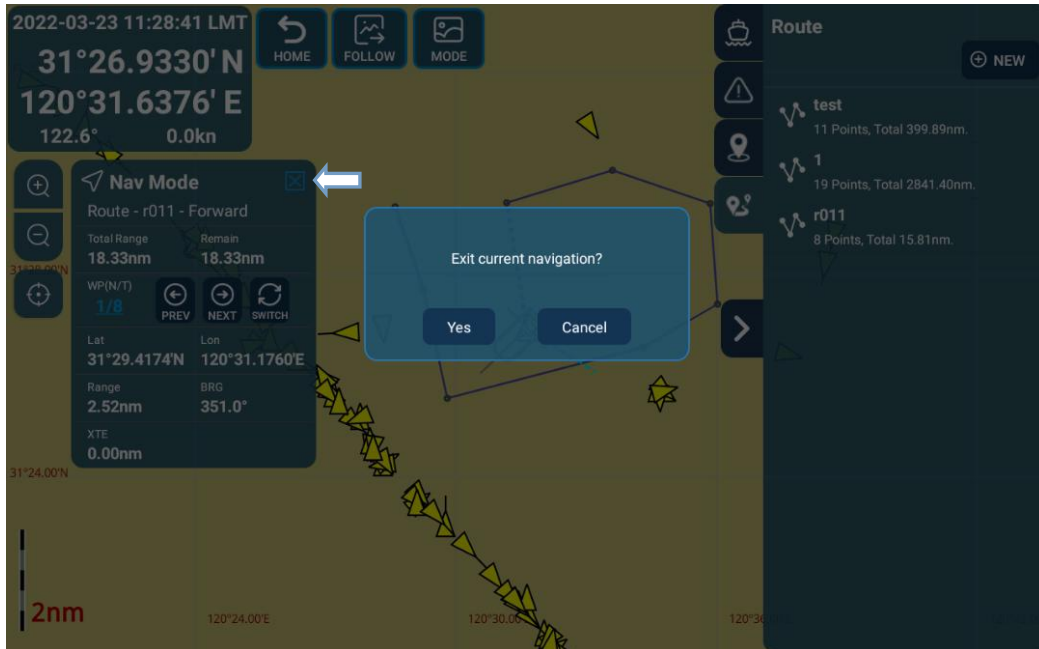

3.4 NAVIGATION MODES

Generally, NES-3010(G) plotter has three basic navigation modes: Route Navigation, Point Navigation and Target Navigation. Click can quickly exit all kinds of navigations.

Note: If the plotter is under navigation, make sure you have quitted the current navigation before you open a new navigation or create a new route, otherwise the plotter will show the message as below:

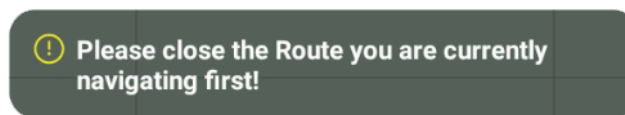

Navigation Mode	Operation Key	Remarks
Way Point		Please refer to Section 3.1.4 & 3.2.2.
Route		Please refer to Section 3.3.4.
AIS Target		Please refer to Section 4.2.2, 4.3.1, 4.3.2.

4. AIS OPERATION

This plotter has a dedicated AIS interface, can be connected with ship borne AIS equipment, NSR NSI-1000 or NAB-1000. No matter which AIS equipment is connected with, please make sure to select the right AIS model by setting the “AIS Class” in [SETTING] – [System Setting], otherwise the plotter may not receive the AIS messages properly.

When connected to ship borne AIS, surrounding AIS targets can be displayed in real time on Map.

4.1 ABOUT AIS

4.1.1 WHAT'S AIS

The Automatic Identification System (AIS) is a Very High Frequency (VHF) radio broadcasting system that transfers packets of data over the VHF data link (VDL) and enables AIS equipped vessels and shore-based stations to exchange identification information and navigational data. Ships with AIS transponders continually transmit their ID, position, course, speed and other data to all nearby ships and shore stations.

Such information can aid greatly in situational awareness and provide a means to assist in collision avoidance.

AIS equipment is standardized by ITU, IEC, IALA and IMO and is subject to approval by a certification body.

The following AIS devices have been developed for variant applications.

AIS Class A:

is mandated by the IMO for vessels of 300 gross tonnages and upwards engaged on international voyages, cargo ships of 500 gross tonnages and upwards, as well as passenger ships engaged on domestic voyages. It transmits typically at 12.5-watt output power.

AIS Class B:

provides limited functionality and is intended for non-SOLAS commercial vessels and recreational vessels. It transmits typically at 2-watt output power.

AIS Base Station:

is provided by aids-to-navigation authorities to enable the ship to shore / shore to ship transmission of information. Networked AIS Base Stations can assist in providing overall maritime domain awareness.

AIS AtoN (Aids to Navigation):

provides an opportunity to transmit position and status of buoys and lights through the same VDL, which can then show up on AIS-ready devices within the range.

AIS LOCATING DEVICE:

There are three types of AIS locating devices, AIS SART, AIS EPIRB and AIS MOB. They can be used

to assist in determining the location of a vessel or a person in distress. They are typically used on life rafts.

AIS on Search and Rescue (SAR) Aircraft:

is used on airplanes and helicopters to assist search and rescue operation.

4.1.2 SHIP'S DATA

The below data is related to AIS class A.

- **Static Data**
 - Ship's Name and Call Sign (when available)
 - MMSI (Maritime Mobile Service Identification)
 - IMO Number (when available)
 - Length and Beam
 - Ship Type
- **Dynamic Data**
 - Ship's Position
 - UTC
 - Course Over Ground (COG)
 - Speed Over Ground (SOG)
 - Heading
 - Navigation Status
 - Rate of Turn (when available)
- **Voyage Related Data**
 - Draught
 - Dangerous Cargo (Type)
 - Destination and ETA
 - CPA (Closest Point of Approach)
 - TCPA (Time to Closest Point of Approach)
- **Short Safety Related Message, Text Message**

4.2 AIS TARGETS ON CHART/MAP

4.2.1 TARGET ICON

Different AIS targets will be displayed in different name or icon as below:

Target	Target list display	Icon display
Own Ship		
AIS Class A	Class A	
AIS Class B	Class B	
AIS Base Station	Base Station	
AIS AtoN Station	AtoN	
AIS-SART	SART	
AIS EPIRB	EPIRB	
AIS MOB	MOB	

On [NAVIGATION] screen, click an AIS target, detailed information will pop up, including static info, dynamic info and voyage-related info.

For example:

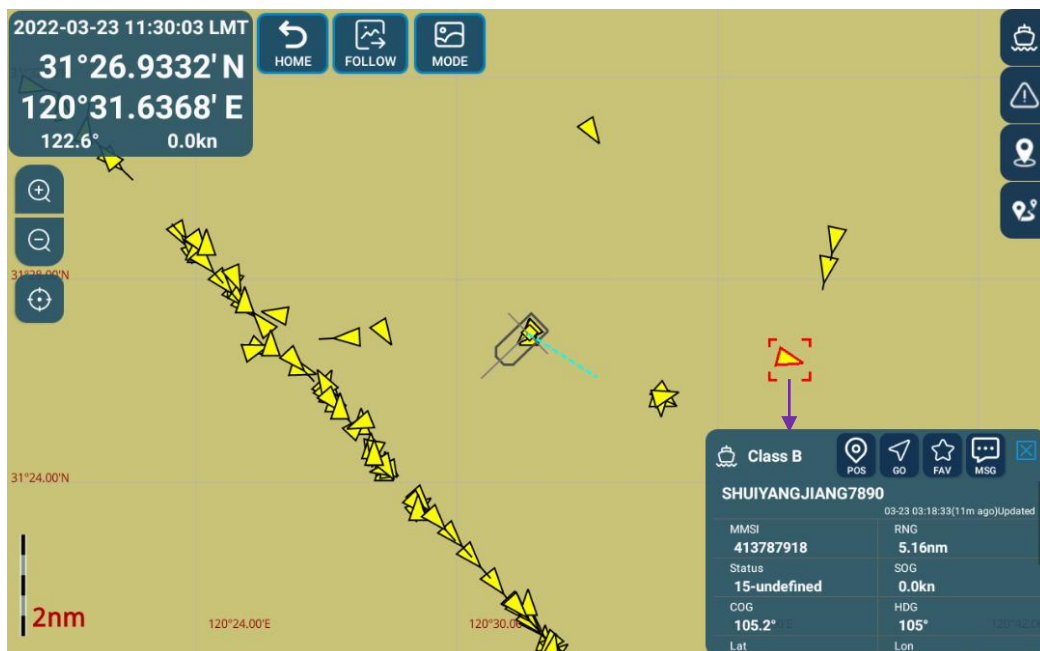

You can swipe to see the full information of AIS target.



4.2.2 AIS LIST

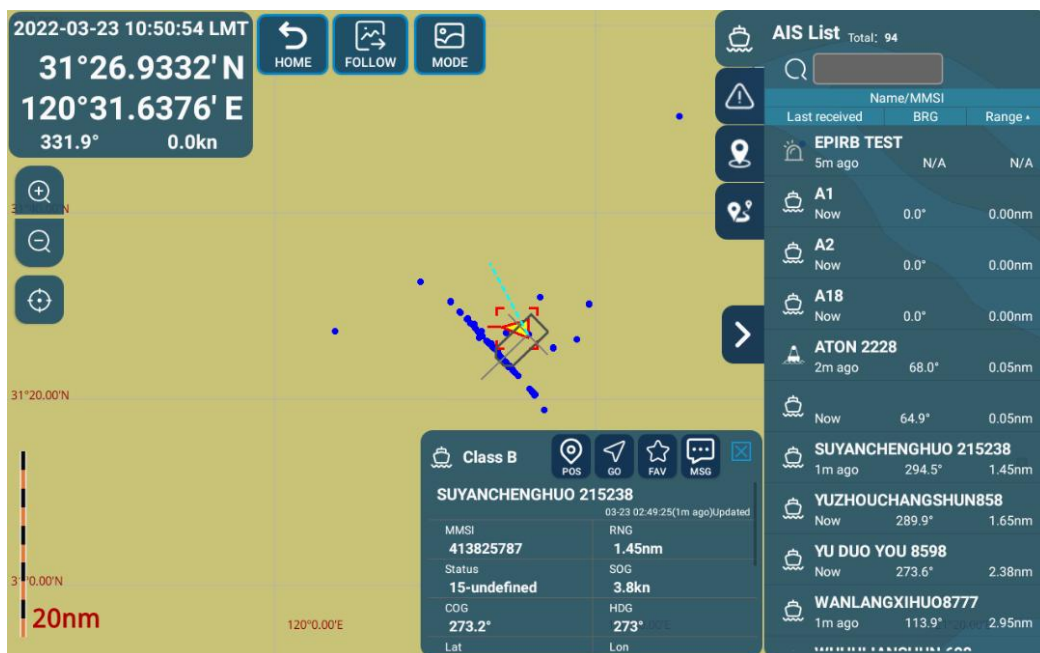

This simple **AIS List** shows the list of AIS targets received. Click to select an AIS target. For example: You can check the detailed information of a selected AIS target.



: Put the AIS target in the centre of screen.



: Start the navigation to the AIS target.
It'll draw a blue line between own ship and the target.



: Collect the AIS target in the Favorites List.



: Send AIS message to the AIS target.

Please refer to **Section 4.3.1**.

4.2.3 DANGEROUS LIST



CPA/TCPA is calculated for each target vessel with own ship. If a target is falling into the preset CPA/TCPA value, it will be regarded as a DANGEROUS TARGET and listed in **Dangerous List**.

4.3 MENU OPERATION



Click  on main screen, then the following [AIS] screen appears:

AIS List		Number of list: 103		
<input checked="" type="checkbox"/> Ship	MMSI	RNG	SOG	Operation
<input checked="" type="checkbox"/> Other	Name	BRG	COG	
Class B	000000000	0.05nm 66.9°	0.0kn 0.0°	POS FAV MSG
Base Station	004132301 N/A	35.57nm 59.2°	0.0kn 0.0°	POS FAV MSG
Base Station	004132392 N/A	20.56nm 270.9°	0.0kn 0.0°	POS FAV MSG
Base Station	004132432 N/A	8.28nm 166.3°	0.0kn 0.0°	POS FAV MSG
Class A	412666001 A1	0.00nm 0.0°	0.0kn 122.6°	POS FAV MSG
Class A	412666002 A2	0.00nm 0.0°	0.0kn 122.6°	POS FAV MSG
Class A	412666018 A18	0.00nm 0.0°	0.0kn 122.6°	POS FAV MSG
Class A	413265430 N/A	32.13nm	13.8kn	POS FAV MSG

It includes **AIS LIST** and **FAVORITIES** items.

4.3.1 AIS LIST

AIS List displays AIS targets' information about MMSI / Name / RNG (range) / BRG (bearing) / SOG/COG/ AIS Type.

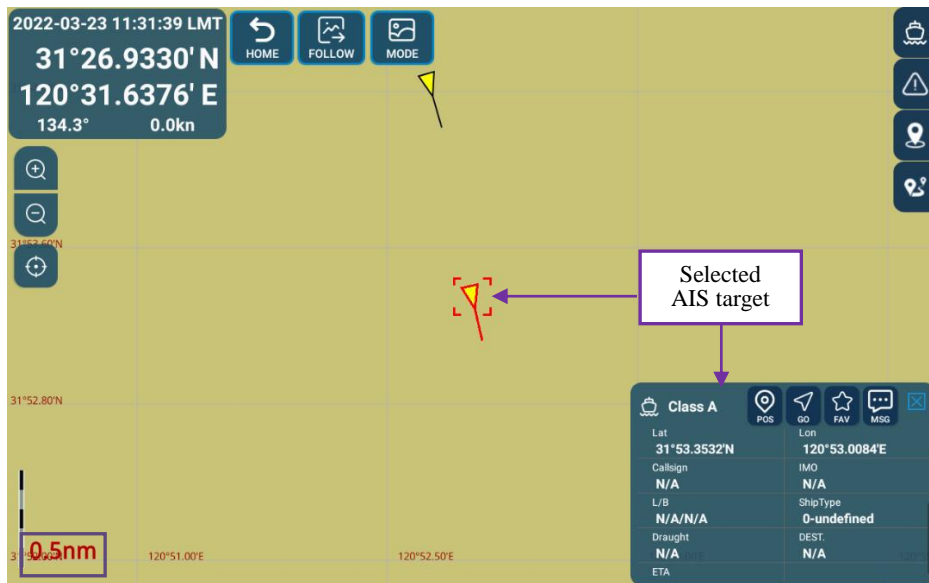

The operations of **AIS List** include:

- **GO TO SHIP:** Click , then the screen will change to navigation mode. And the detailed information of the target is displayed.



Click  in detailed information to locate the selected ship at the center of chart.



- FAVORITE:** Click  will record the AIS target in the **Favorites List**, then you can see the message “Added to Favorites”. Please refer to **Section 4.3.2**.
- SEND MSG:** Click  will send message to the selected AIS target. Selecting this can open the new message window immediately. Edit the message and send it. You don't need to input the MMSI. For detailed operation, please refer to **Section 4.3.8**.

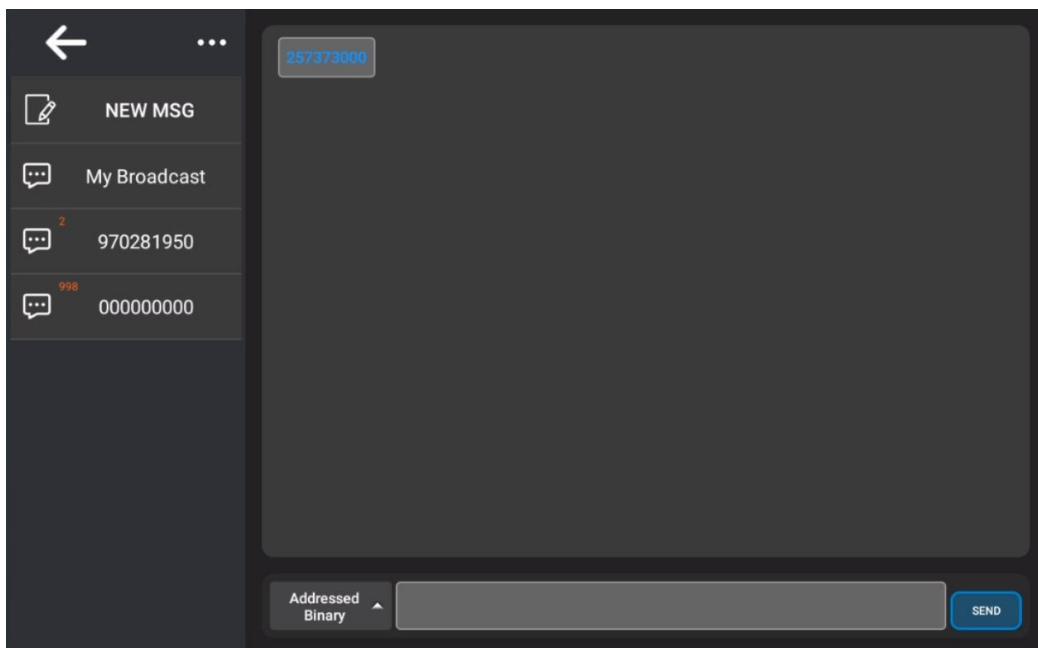

- SORT:** AIS targets can be listed by three options, by **MMSI**, by **RNG**, by **SOG**. Each can be in ascending order or descending order. When entering the [AIS] screen, the AIS target will be listed by MMSI ascending as default. Ascending symbols () can be seen to the right of **MMSI**.

		MMSI	RNG	SOG	Operation		
		Name	BRG	COG	POS	FAV	MSG
Class B	000000000		0.03nm 116.3°	0.6kn 0.0°			
Base Station	004128005	N/A	647.95nm 219.5°	0.0kn 0.0°			
Base Station	004128012	N/A	688.39nm 220.8°	0.0kn 0.0°			
Base Station	004132301	N/A	35.57nm 59.2°	0.0kn 0.0°			
Base Station	004132432	N/A	8.28nm 166.3°	0.0kn 0.0°			
Base Station	004132433	N/A	23.86nm 300.7°	0.0kn 0.0°			
Class A	210872000	N/A	34.24nm 34.8°	11.8kn 338.9°			
Class B	412465189		697.34nm	0.2kn			

Click **MMSI** again, then the AIS targets will be listed by MMSI in descending order.

Descending symbols () can be seen as follows:

		MMSI	RNG	SOG	Operation		
		Name	BRG	COG	POS	FAV	MSG
Base Station	905120003	N/A	N/A	0.0kn			
Class B	666888014		0.04nm 71.5°	0.2kn 0.0°			
Class B	666888013		0.04nm 56.1°	0.0kn 0.0°			
Class B	666888012		0.03nm 67.8°	0.2kn 0.0°			
Class B	666888011		0.04nm 79.2°	0.0kn 0.0°			
Class B	666888010		0.05nm 48.7°	0.0kn 0.0°			
Class B	666888009		0.04nm 68.2°	0.0kn 0.0°			
Class B	666888008		0.05nm	0.0kn			

The other two options are the same. For example, click **SOG**, then the AIS targets will be listed by SOG ascending (). Click **SOG** again, then the AIS targets will be listed by SOG descending ().

		MMSI	RNG	SOG	Operation		
		Name	BRG	COG			
Class B	413791151	HONGSHUN928	1.49nm 9.5°	0.0kn 29.4°	POS	FAV	MSG
Class B	413823649	N/A	N/A	0.0kn 0.0°	POS	FAV	MSG
Class B	413961913	JINHANG1188	4.01nm 215.9°	0.0kn 0.0°	POS	FAV	MSG
Class B	413996725	PINGNAN SHUNHUI 2813	697.47nm 221.0°	0.0kn 275.9°	POS	FAV	MSG
Class B	413777036	WANCHIZHOUHUA998	3.72nm 228.5°	0.0kn 219.2°	POS	FAV	MSG
Class A	413822338	HENG DA 6688	5.32nm 273.2°	0.0kn 0.0°	POS	FAV	MSG
Class A	414000000		0.00nm 0.0°	0.0kn 136.8°	POS	FAV	MSG
Base Station	004128012		688.39nm	0.0kn	POS	FAV	MSG

		MMSI	RNG	SOG	Operation		
		Name	BRG	COG			
Class B	412493905	N/A	694.91nm 221.0°	73.6kn 202.4°	POS	FAV	MSG
Class B	413824354	N/A	3.76nm 233.1°	30.4kn 137.5°	POS	FAV	MSG
Class A	477397100	N/A	32.33nm 39.2°	12.9kn 343.8°	POS	FAV	MSG
Class A	413231160	XIN FENG QI 1	33.64nm 36.2°	12.4kn 337.4°	POS	FAV	MSG
Class A	636016836	FPMC B NATURE	30.21nm 43.5°	11.8kn 157.8°	POS	FAV	MSG
Class B	413840946	N/A	3.87nm 219.0°	6.6kn 139.0°	POS	FAV	MSG
Class B	413761459	N/A	4.60nm 264.4°	5.8kn 317.3°	POS	FAV	MSG
Class B	413774325		3.25nm	5.8kn	POS	FAV	MSG

- SEARCH:** You can enter MMSI or Name in search box by pop-up soft keypad to find the AIS target. Click  to close the pop-up soft keypad.

By MMSI:

Enter MMSI digits to locate a ship.

When first 4 or more digits are entered, all ships with MMSI started with the same 4 or more digits will show up immediately. It may help to locate a ship easily.

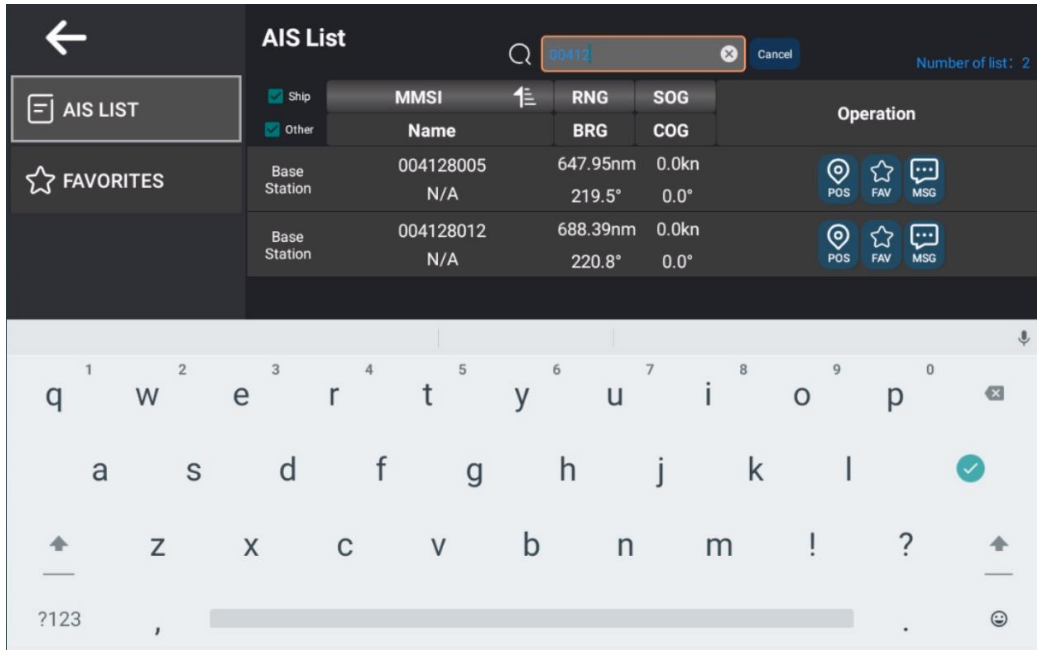

By Name:

Enter ship name to locate a ship. The operation procedure is similar as “By MMSI”.

- **DETAILS:** Click any AIS target in **AIS List**, you can check the details of the target. For example:

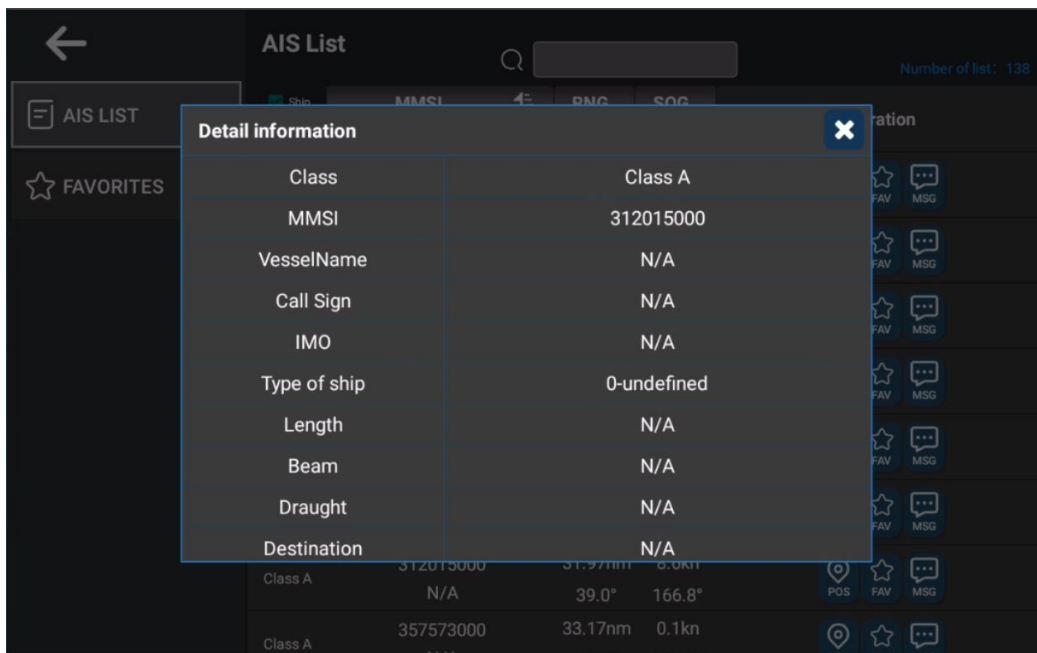

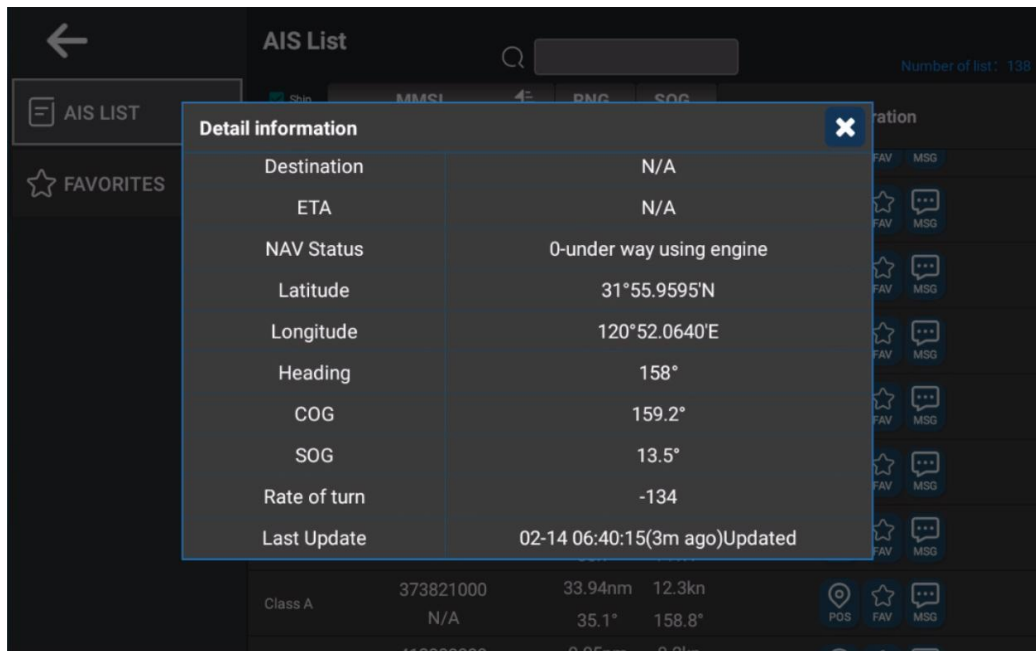

4.3.2 FAVORITES

Click to open the **My Favorites** List. It shows all favorite AIS targets (friend ships or marked ships etc.) saved by clicking . Swipe up / down to view all. If the AIS message sent by the favorite ship has been received, the name of the ship will be displayed below the MMSI. If the message has not been received, there will be an information displayed in red to indicate that it is not in receiving area. The color block on the right shows the background color of the target in the chart (green as default).

No.	Name	Remark	Color	Operation
1	004132432 N/A	base	Blue	DEL POS MSG
2	004132433 N/A	base	Blue	DEL POS MSG
3	212345678	Add remark	Green	DEL POS MSG
4	413862262 Not in receiving area	Add remark	Blue	DEL
5	413961641 Not in receiving area	Add remark	Pink	DEL
6	413961462 WANQUANJIAOHUO0623	Add remark	White	DEL POS MSG
7	413995523 JIANGSUSANHANGTUO10	Add remark	Green	DEL POS MSG
8	413995691 Not in receiving area	Add remark	Green	DEL

The operations of [My Favorites] include (mainly select MMSI-413961462 as example):

- **GO TO SHIP:** Click , then the screen will change into navigation mode. And the detailed information of the ship is displayed.



- **SEND MSG:** Click  to send a message to the selected ship. Selecting this can open the new message window immediately. Edit the message and send it. You don't need to input the MMSI. For detailed operation, please refer to **Section 4.3.8**.

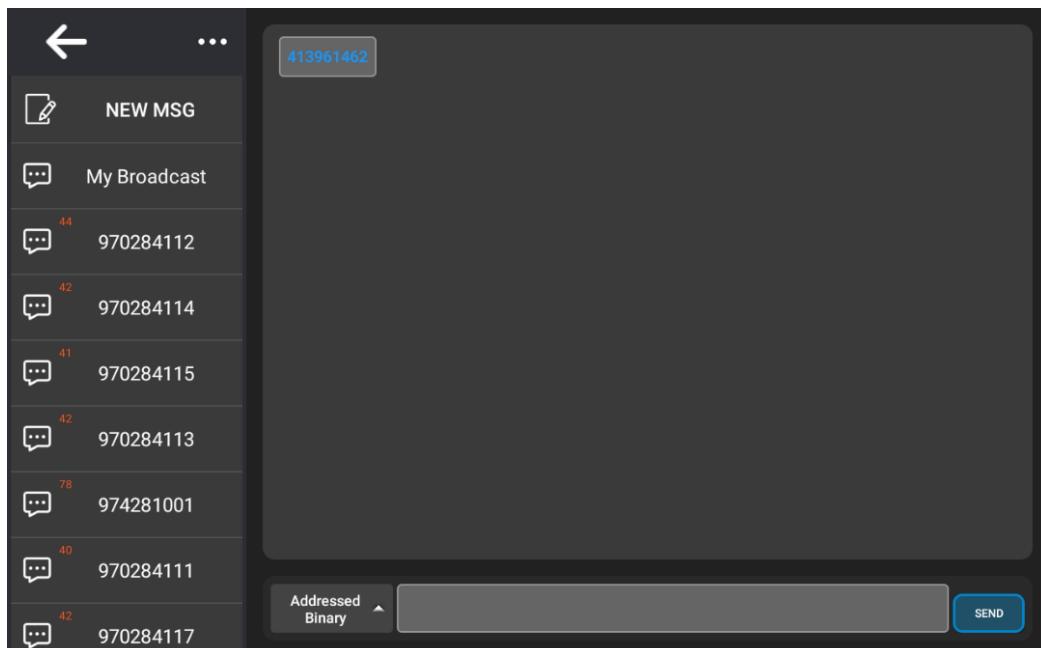

- **DELETE FAVORITE:** Click  to delete the selected one (for example: MMSI-413862262) directly.

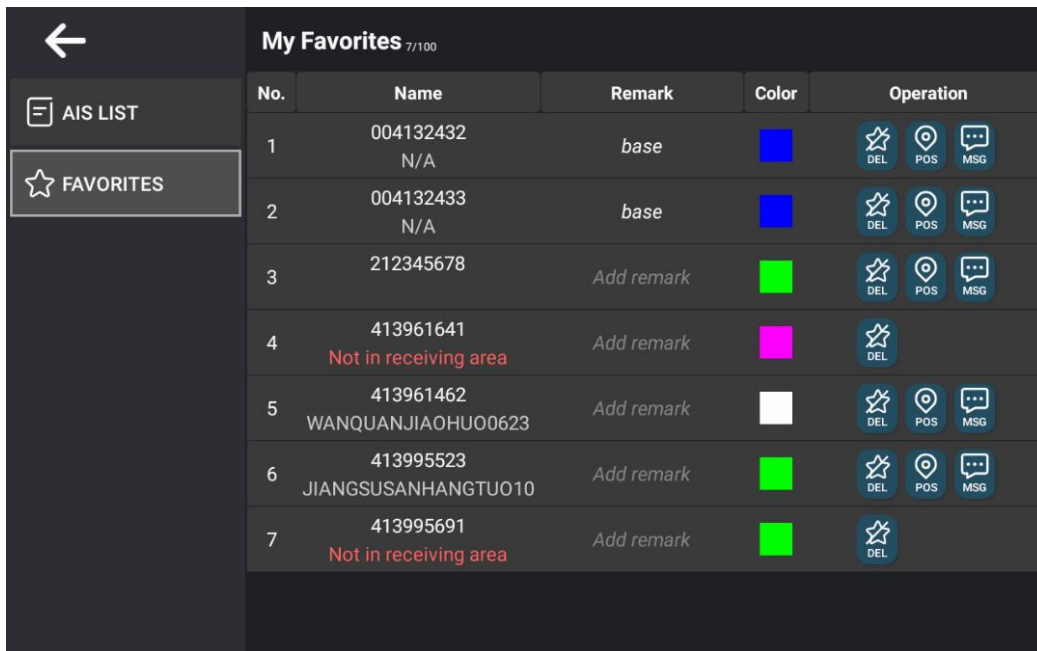

- **FRIEND SHIPS:** AIS friend is a special feature of this plotter. It helps to identify the “own” ships of the same company or group from other ships. The AIS friend has different color from other ships. You can also mark the targets in [My Favorites].

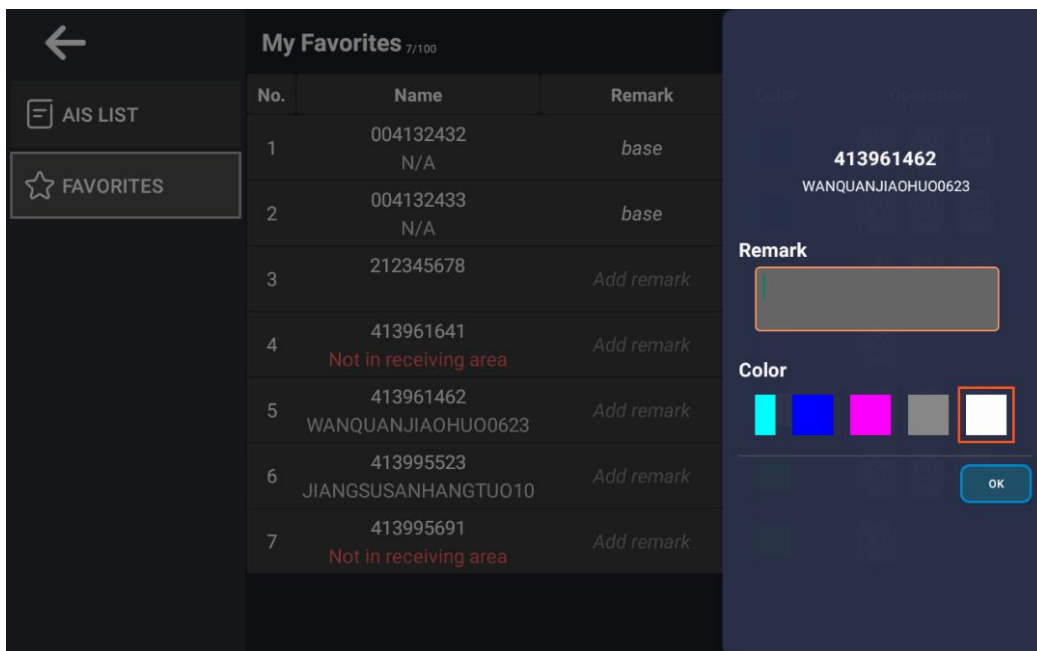

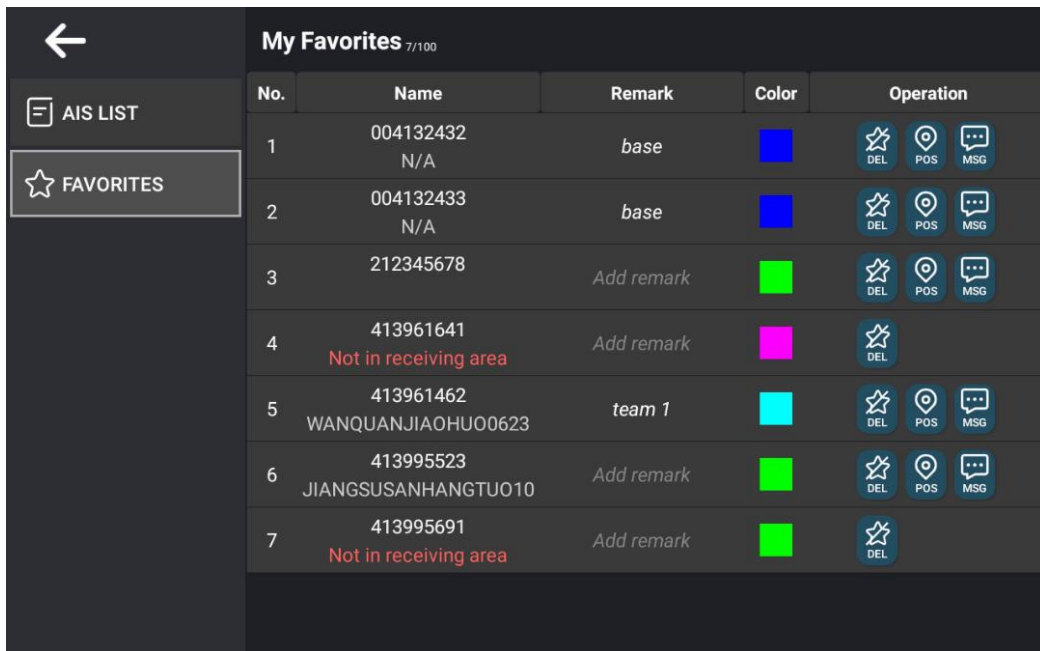
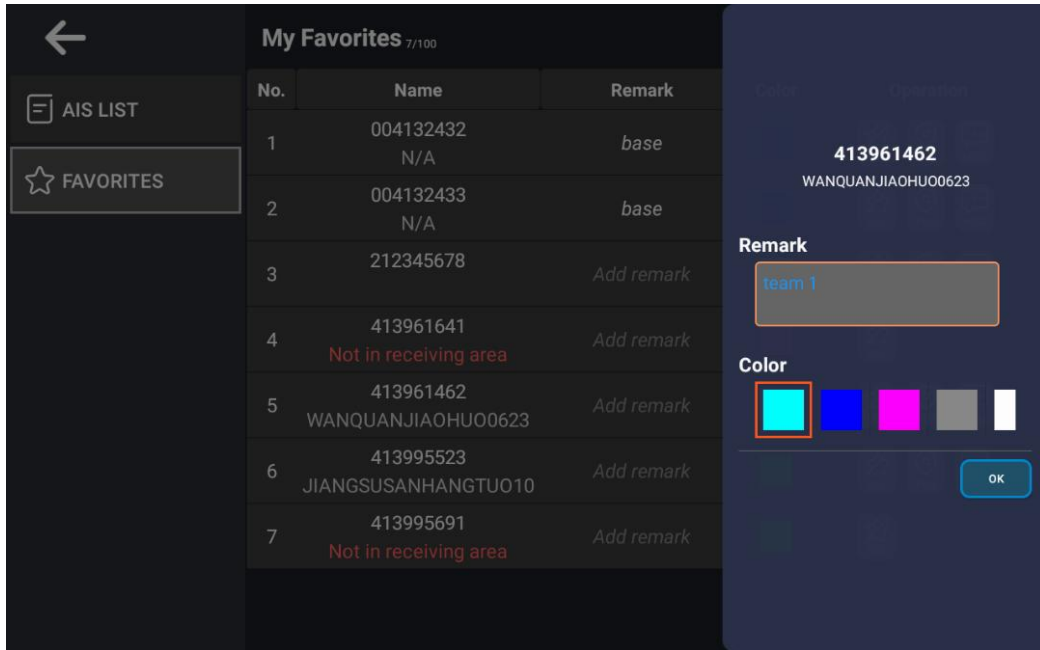

4.3.3 VIEW OWN SHIP INFORMATION

Click  on main screen, then the following [OWNSHIP] screen appears:

NSI-1000 MKD:

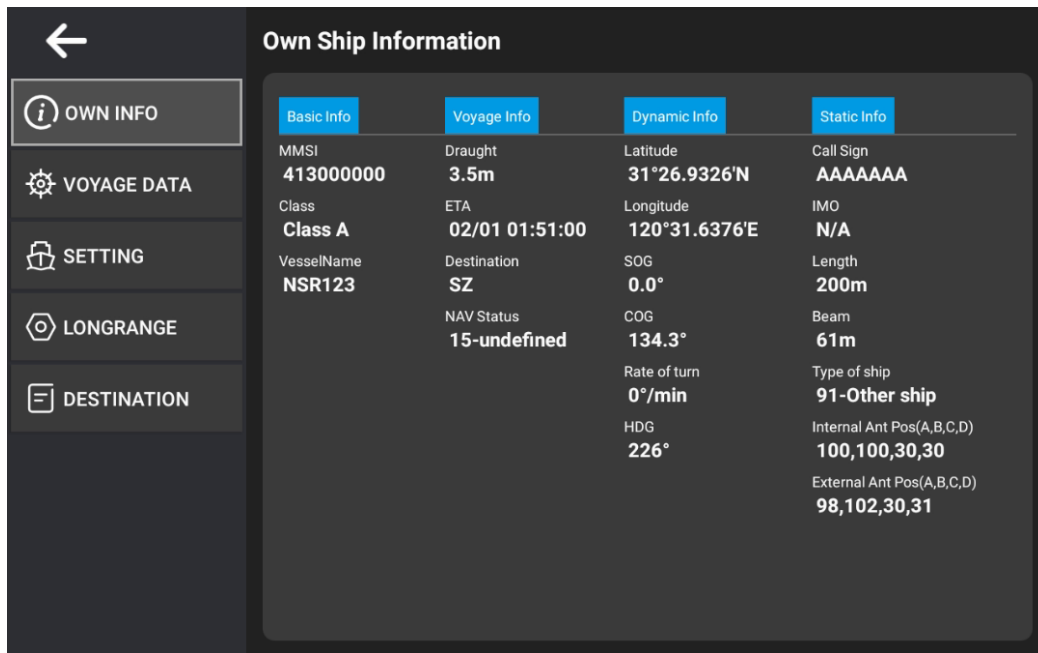

NAB-1000 MKD:

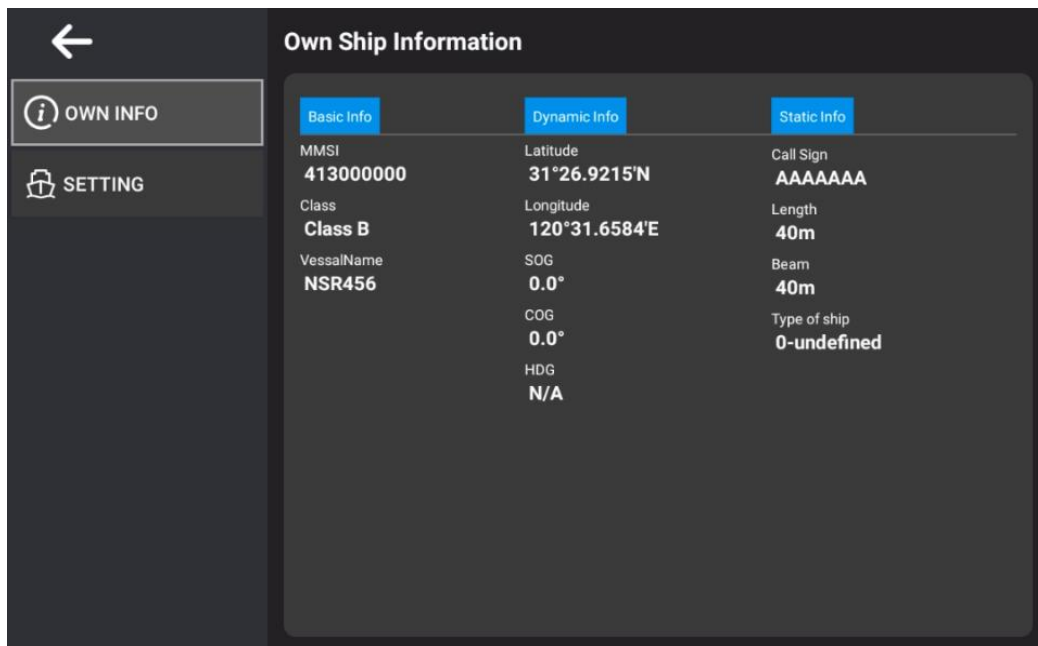

In **OWN INFO** item, you can view the Basic/Voyage/Dynamic/Static information of own ship as above.

4.3.4 VOYAGE DATA (NSI-1000 MKD)

In **VOYAGE DATA** item, you can check and set the Voyage Data of own ship as follows.

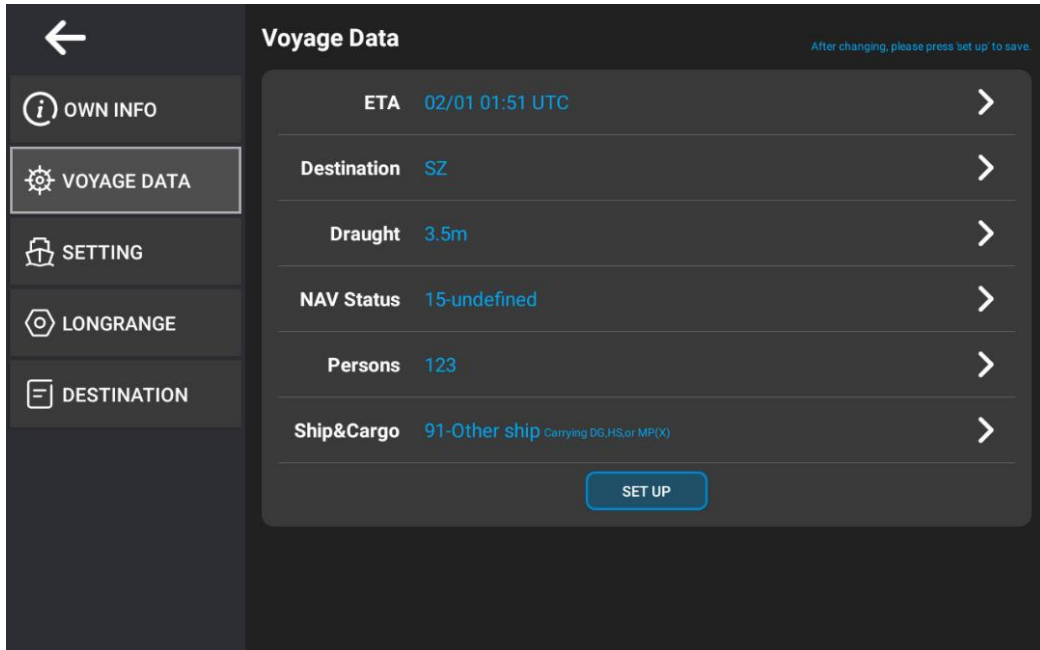

Click to set each item, and click to confirm the changing. For example:

- **ETA**

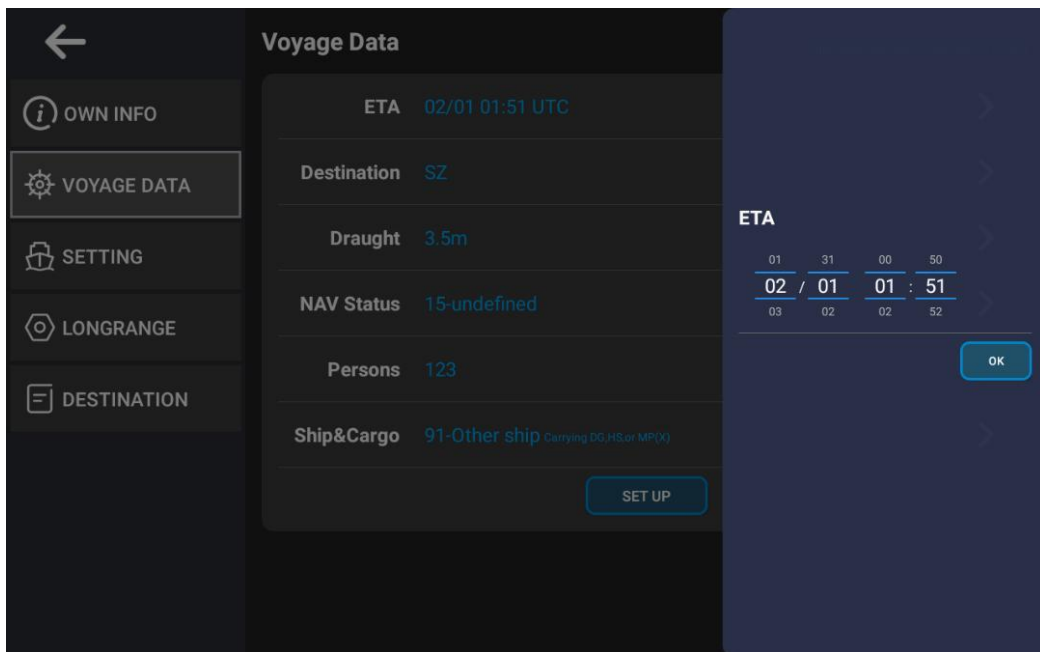

Swipe up / down to set ETA.

- **Destination**

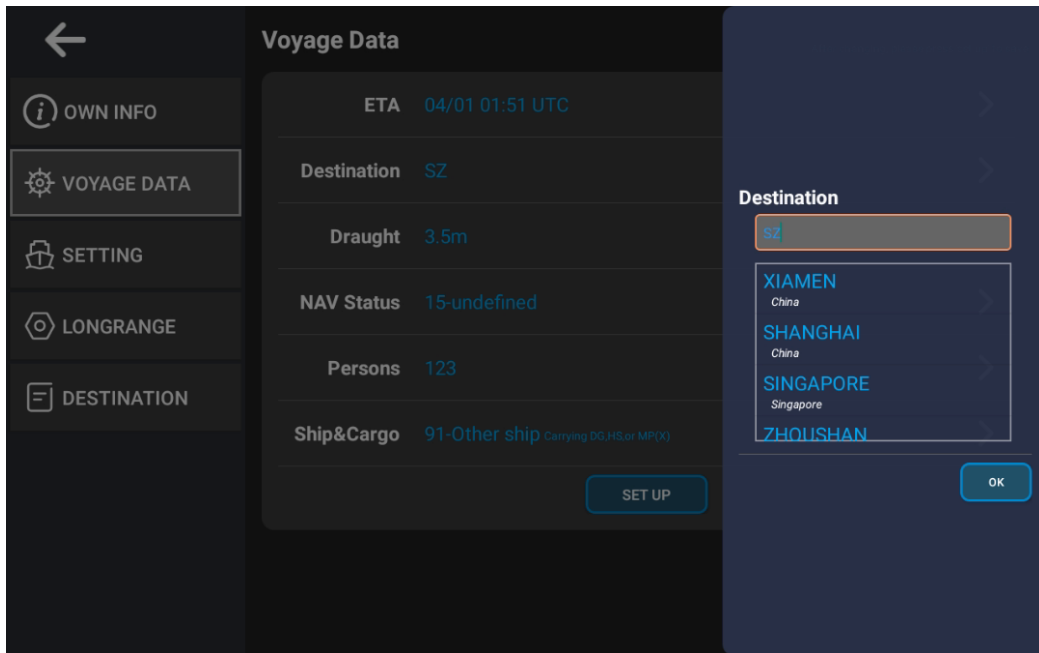

Set the destination by the pop-up soft keypad or call from the destination list.

Note: New destination can be added to the list by clicking at the upper right corner of [DESTINATION] - [My Destination List] window. Please refer to **Section 4.3.7**.

- **Draught**

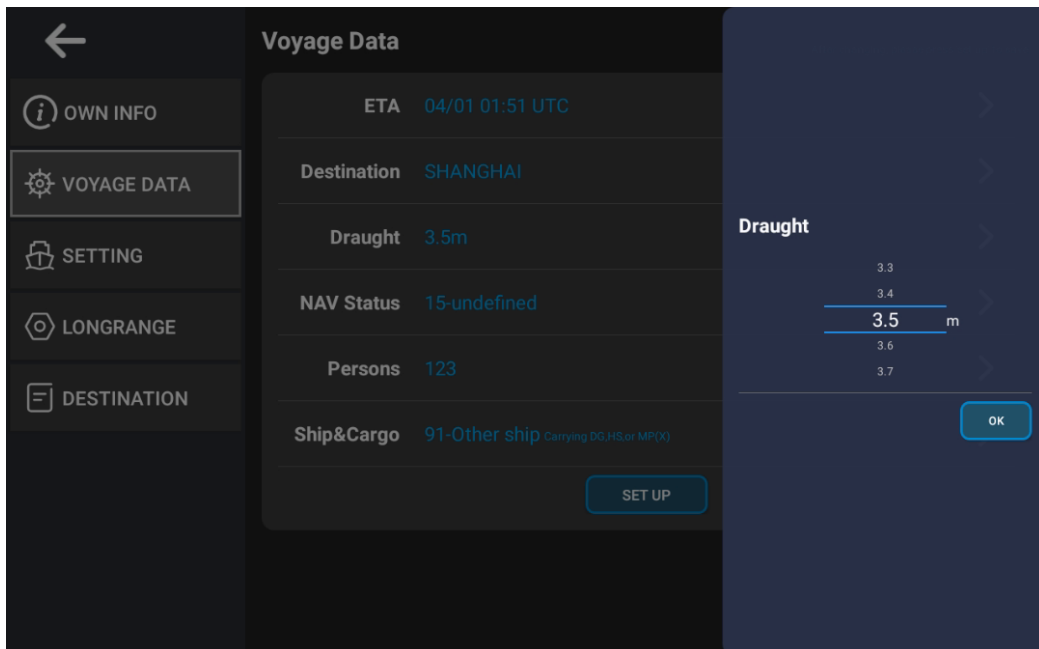

Swipe up / down to set the draught.

● NAV Status

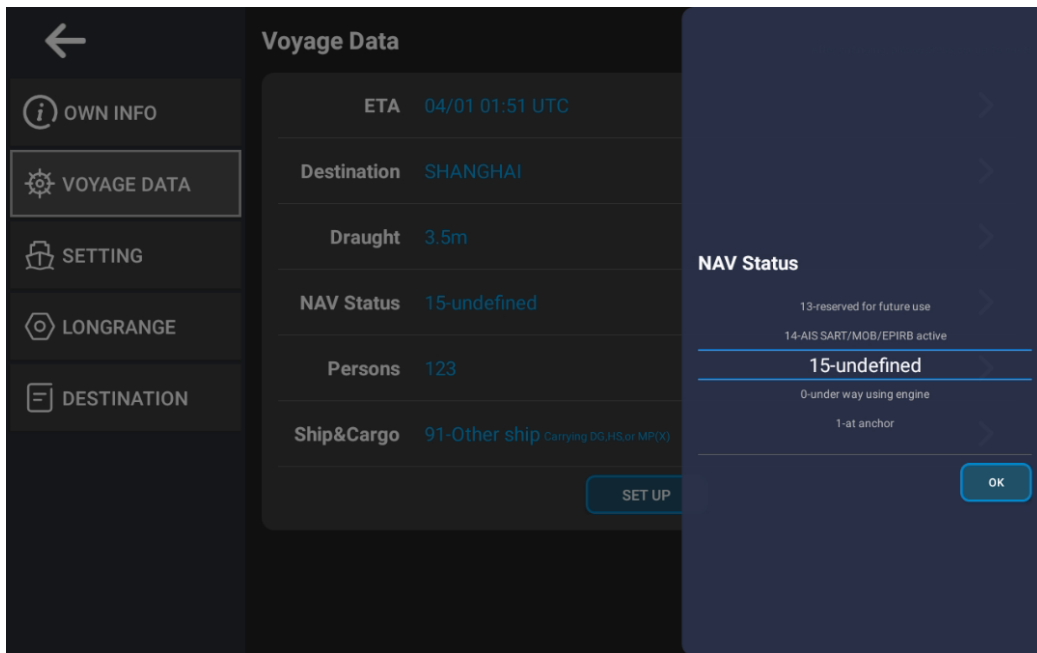

Swipe up / down to set the navigation status. You may select the code from the blow list.

No	Navigation Status
0	under way using engine (Default)
1	at anchor
2	not under command
3	restricted manoeuvrability
4	constrained by draught
5	moored
6	aground
7	engaged in fishing
8	under way sailing
9	reserved for HSC
10	reserved for WIG
11	towing astern
12	pushing ahead
13	reserved for future use
14	AIS SART/MOB/EPIRB active
15	undefined

● **Persons**

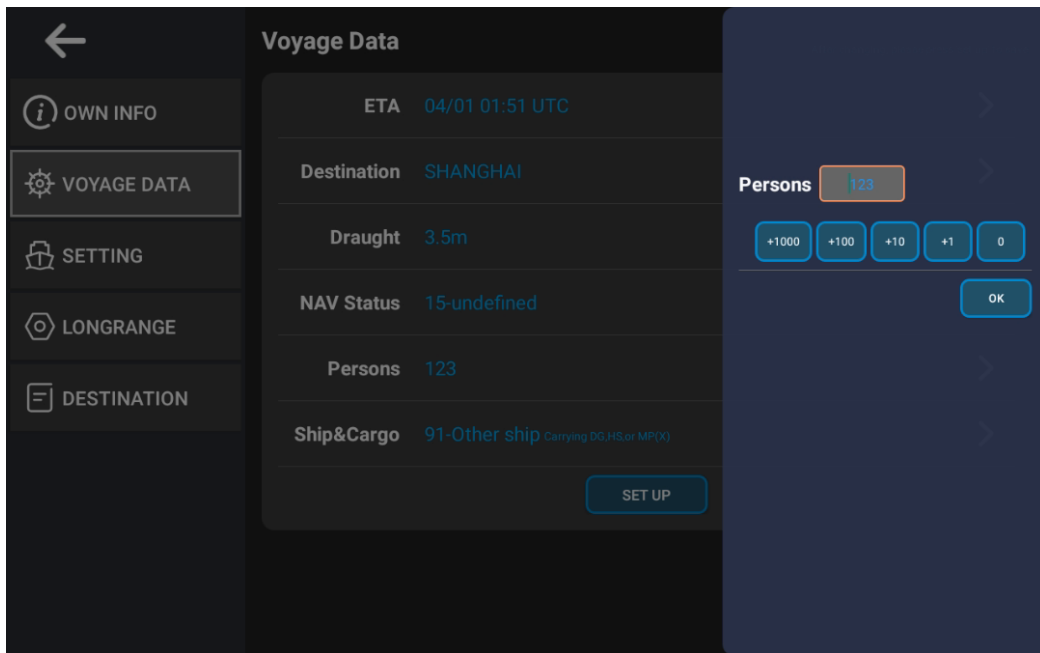

Set the person number by the pop-up soft keypad or

● **Ship&Cargo**

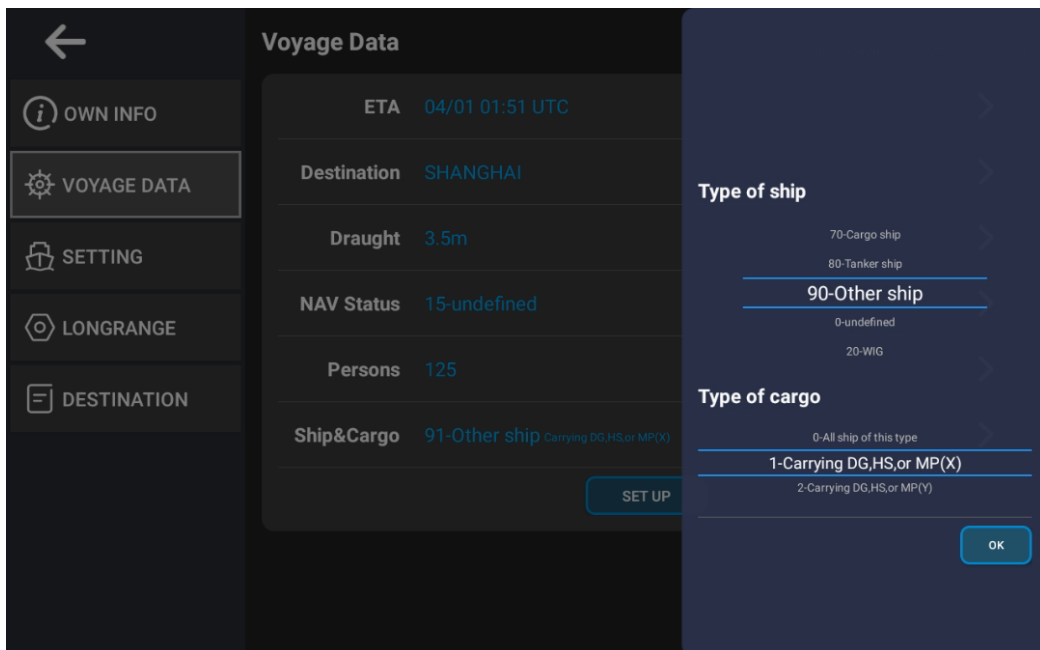

Swipe up / down to set the type of ship and cargo. You may select the cargo type from the blow list. For ship type, please refer to **APPENDIX 3**.

No	Cargo Type
0	All ship of this type
1	Carrying DG,HS,or MP(X)
2	Carrying DG,HS,or MP(Y)
3	3-Carrying DG,HS,or MP(Z)
4	Carrying DG,HS,or MP(OS)
5	Future use
6	Future use
7	Future use
8	Future use
9	No Additional info

Note: After changing, please click  to save and wait for the result of communication with NSI-1000. Successful result is as below. Please refer to **Section 8.3**.

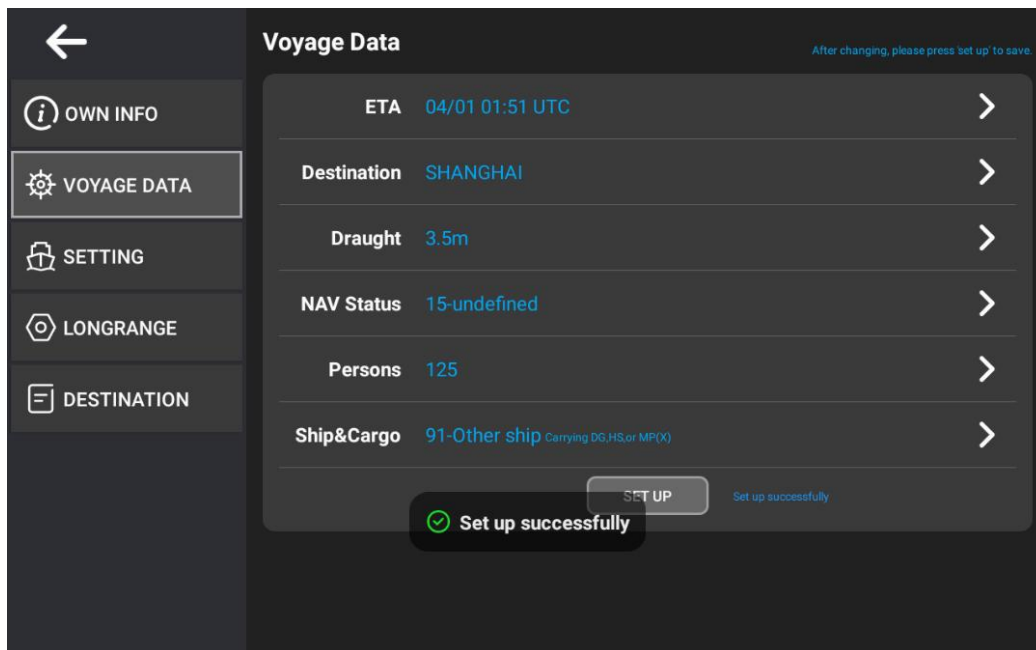

4.3.5 VOYAGE SETTING

In **SETTING** item, you can do the voyage setting as below.

NSI-1000 MKD:

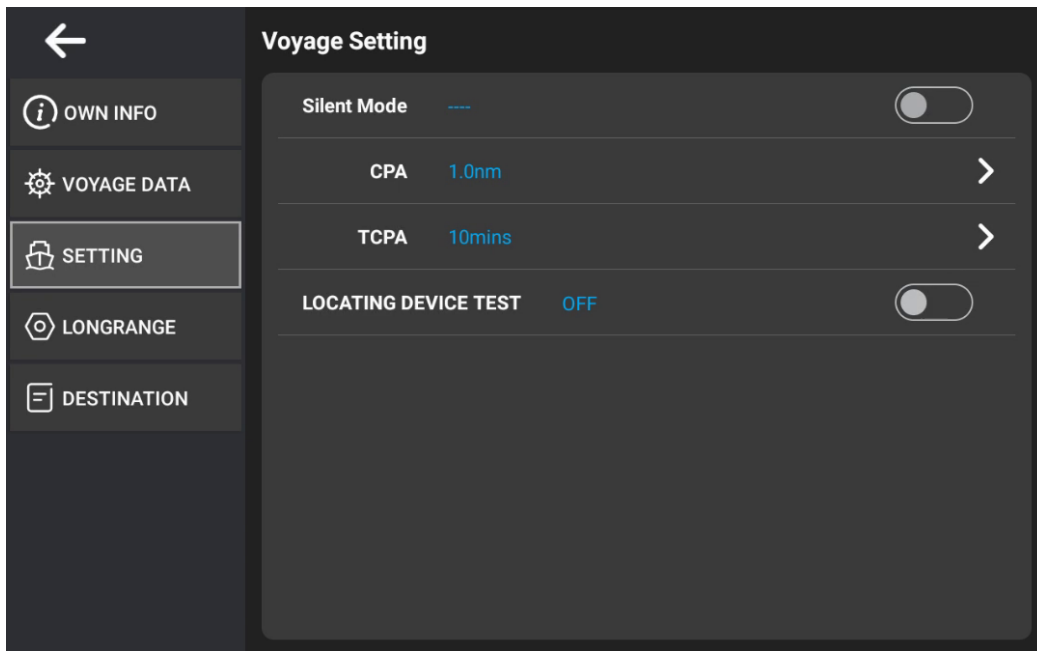

- **Silent Mode**

While **Silent Mode** is set to **ON**, a pop-up message appears on the screen as below. Click  to confirm the setting.

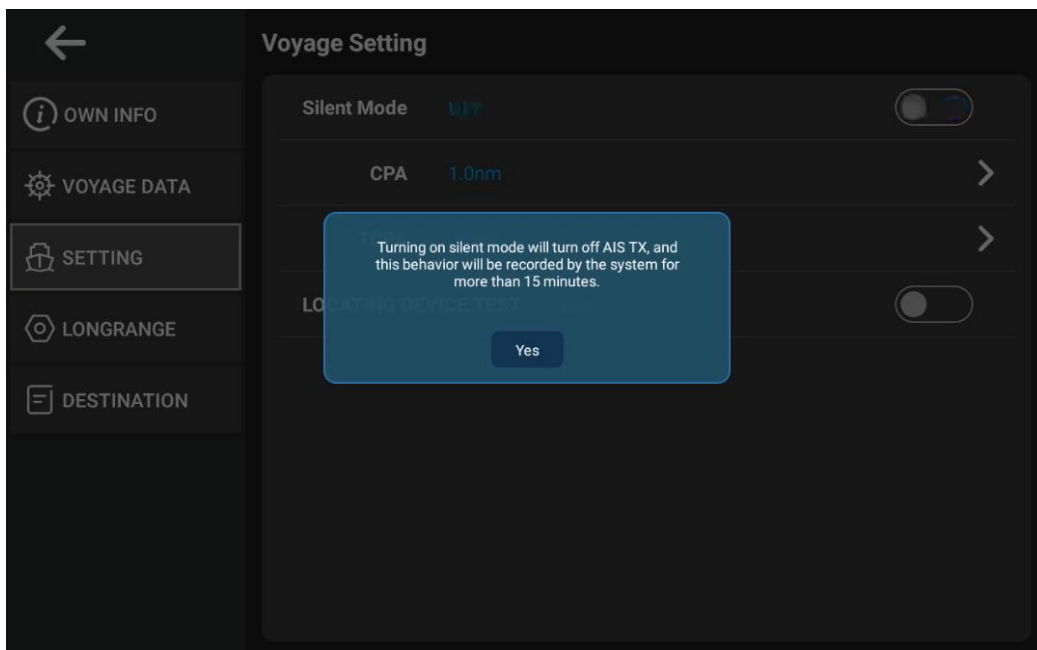

Note: Silent Mode is selected only when does the captain realize that such setting is necessary for safety of navigation. And such setting will be recorded in [AIS DIAGNOTICS] – [EVENT LOG]. Please refer to **Section 4.3.9.3**.

- **CPA /TCPA**

Set the CPA/TCPA value according to captain’s judgment.

When a calculating CPA/TCPA with a target ship is falling into the setting value, an audible alarm will be activated on the screen and the ship will appear in **Dangerous List**.

Note: If CPA/TCPA is set to “0.0”, no dangerous ship is displayed in **Dangerous List**.

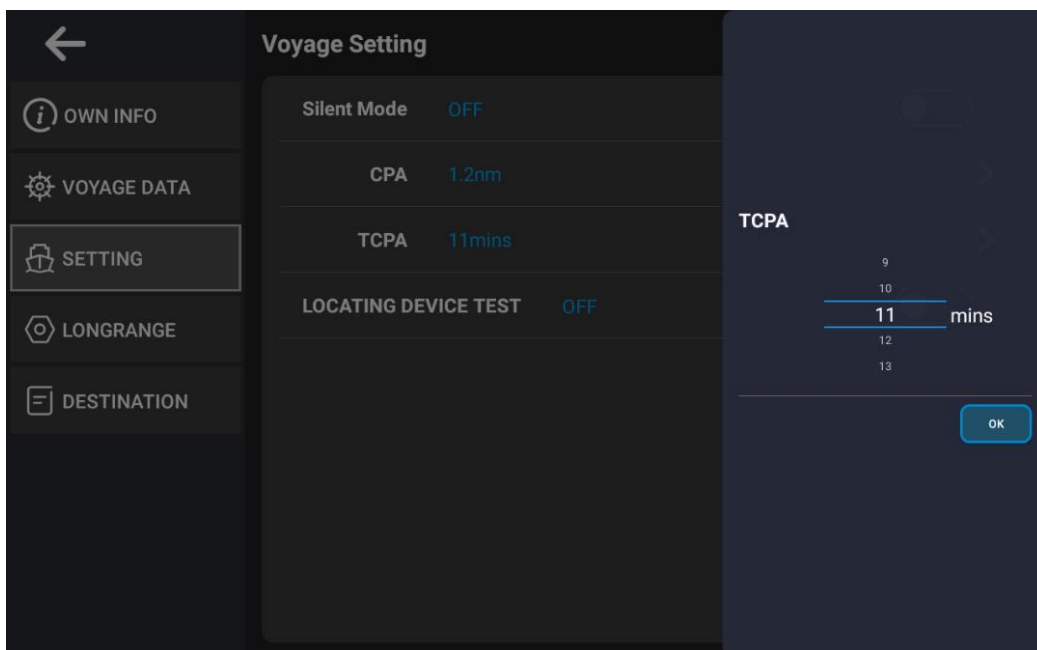
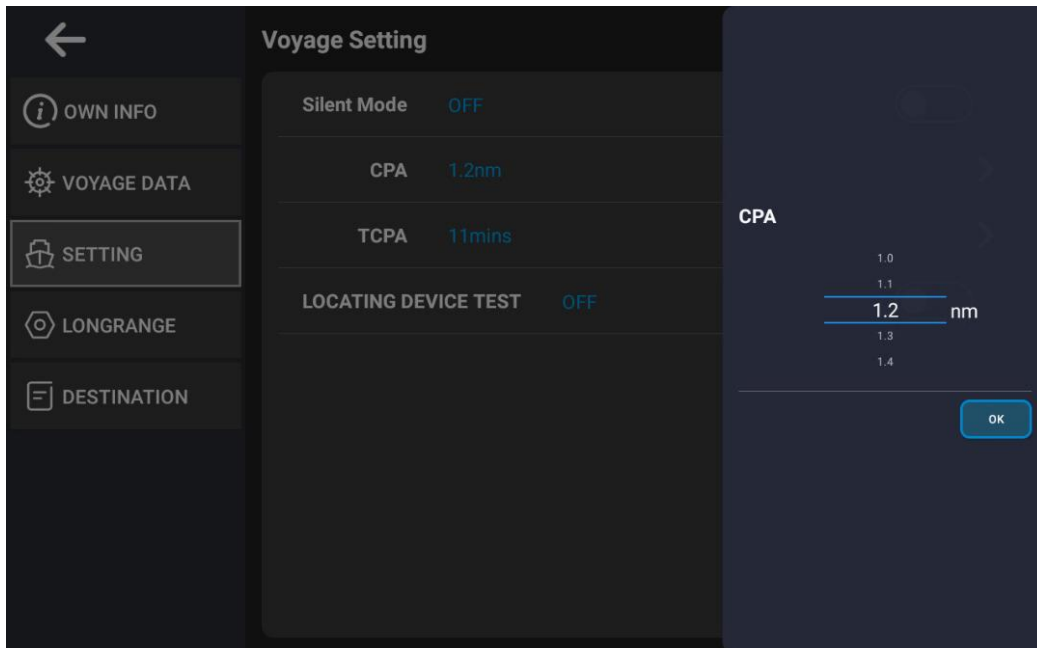

- **LOCATING DEVICE TEST**

This function is used for setting **LOCATING DEVICE TEST ON** or **OFF**, default is **OFF**.

ON: Enable to receive the MOB/SART test signal with alarm sound, and the information will be listed in the AIS List.

OFF: Mute the MOB/SART test signal, and the information will not be listed in the AIS List.

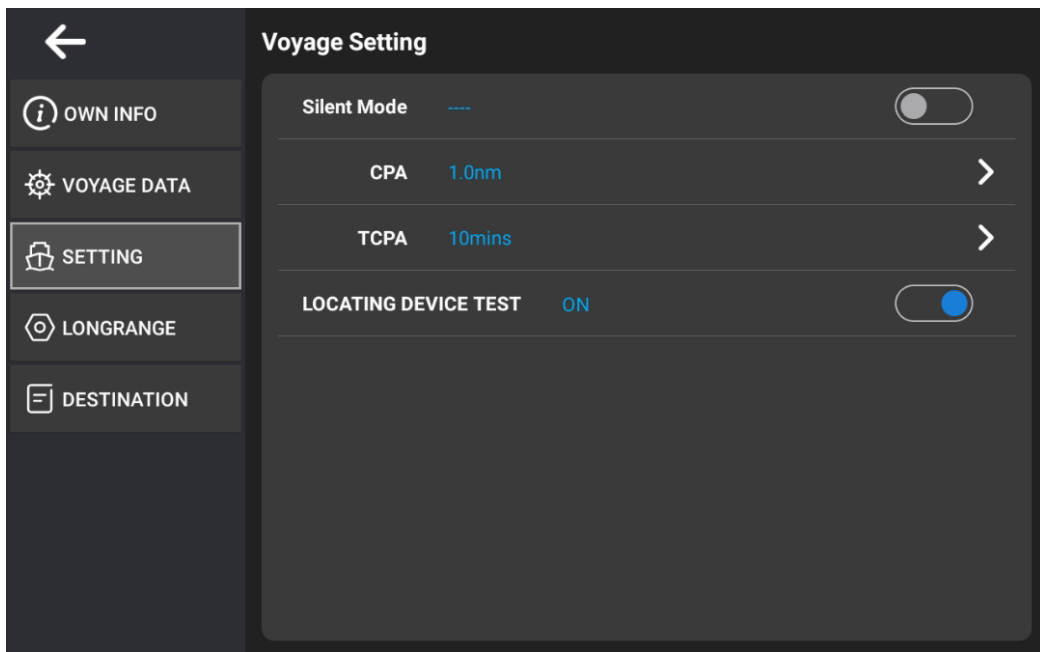

NAB-1000 MKD:

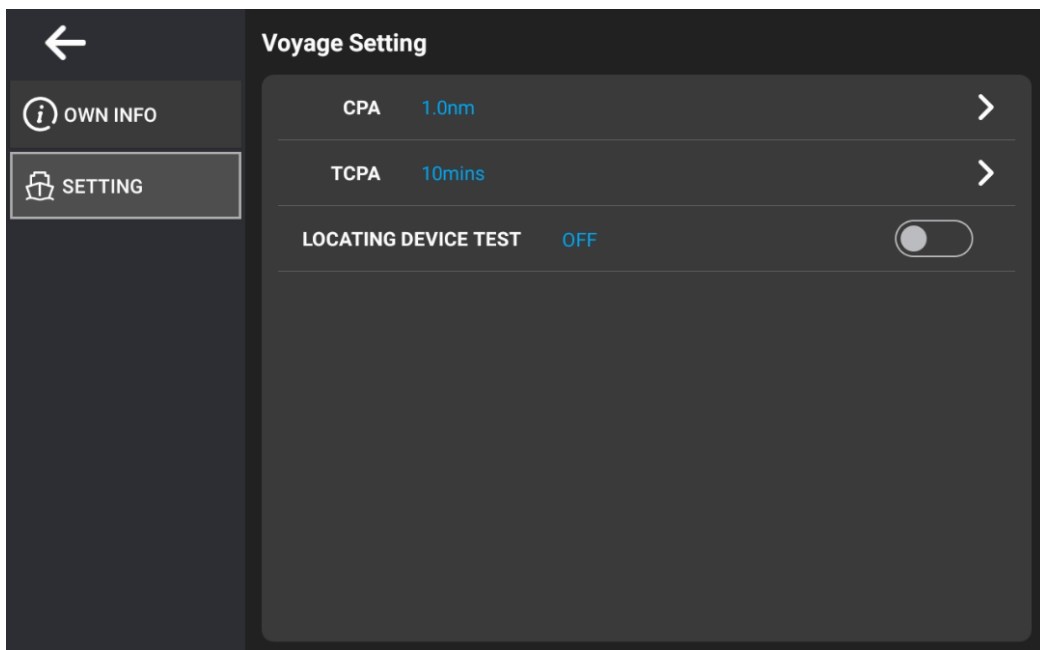

Note: For Class B AIS, **Silent Mode** is not available.

4.3.6 LONGRANGE SETTING (NSI-1000 MKD)

In **LONGRANGE** item, you can do the long range setting as follows.

- **BROADCAST:** Long range broadcast setting, **ON** or **OFF**.
- **Tx Channel 1/2:** The channel of the long range broadcast couldn't be modified.

- **Mode: Auto or Manual.** The long range mode is to allow being set by the user to respond automatically or manually to long range interrogation from such as Inmarsat-C ship earth station. NSI-1000 provides a two-way interface for equipment which provides for long-range communication.
- **Name / Call sign / IMO, ETA, Position, COG, SOG, Destination, Draught, Cargo, Length Beam, Persons:** Response of AIS setting, **ON** or **OFF**.

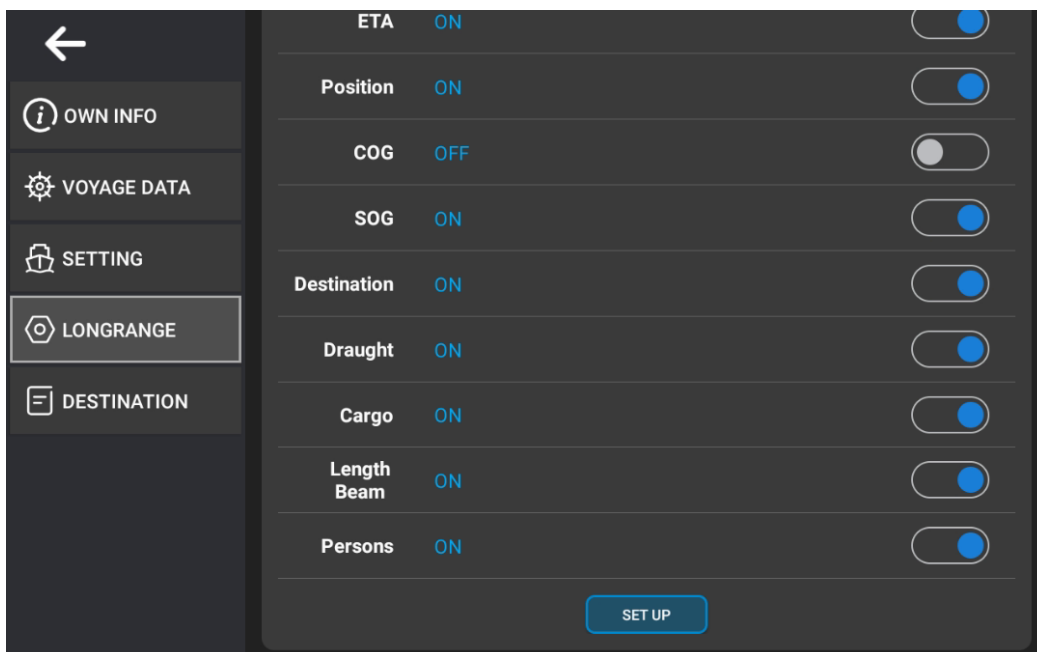
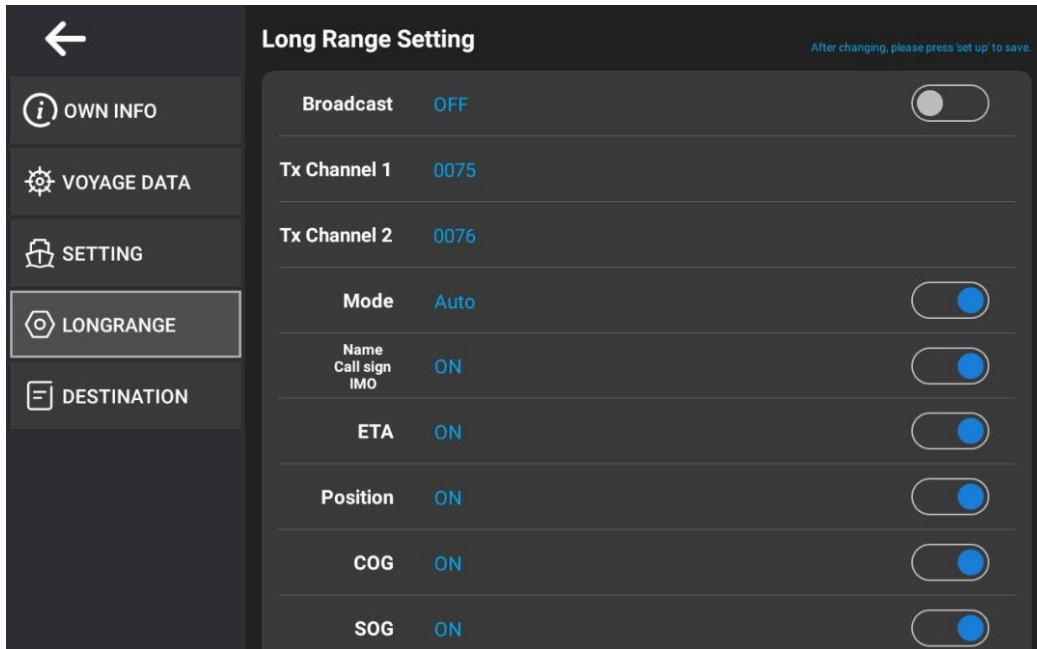

Note: After setting, please click  to save and wait for the result of communication with NSI-1000. Please refer to **Section 8.3**.

4.3.7 DESTINATION LIST (NSI-1000 MKD)

In **DESTINATION** item, you can manage [**My destination List**] as follows.

No.	Destination	Remark	Operation
1	XIAMEN	China	
2	SHANGHAI	China	
3	SINGAPORE	Singapore	
4	ZHOUSHAN	China	
5	GUANGZHOU	China	
6	PUSAN	South Korea	
7	HONGKONG	China	
8	QINGDAO	China	

- **TOP DESTINATION:** Click to top the selected one (for example, SHANGHAI):

No.	Destination	Remark	Operation
1	SHANGHAI	China	
2	XIAMEN	China	
3	SINGAPORE	Singapore	
4	ZHOUSHAN	China	
5	GUANGZHOU	China	
6	PUSAN	South Korea	
7	HONGKONG	China	
8	QINGDAO	China	

- **DELETE destination:** Click to delete the selected one (for example: PUSAN) directly.

No.	Destination	Remark	Operation
1	SHANGHAI	China	DEL
2	XIAMEN	China	TOP DEL
3	SINGAPORE	Singapore	TOP DEL
4	ZHOUSHAN	China	TOP DEL
5	GUANGZHOU	China	TOP DEL
6	HONGKONG	China	TOP DEL
7	QINGDAO	China	TOP DEL
8	TIANJIN	China	TOP DEL

- **NEW DESTINATION:** Click to add a new destination (for example: PUSAN).

New Destination

Destination

Remark

OK

New Destination

Destination

Remark

No.	Destination	Remark	Operation
1	PUSAN	South Korea	DEL
2	SHANGHAI	China	TOP DEL
3	XIAMEN	China	TOP DEL
4	SINGAPORE	Singapore	TOP DEL
5	ZHOUSHAN	China	TOP DEL
6	GUANGZHOU	China	TOP DEL
7	HONGKONG	China	TOP DEL
8	QINGDAO	China	TOP DEL

4.3.8 AIS MESSAGE

Click  on main screen, the following [AIS MESSAGE] screen appears:

NSI-1000 MKD:

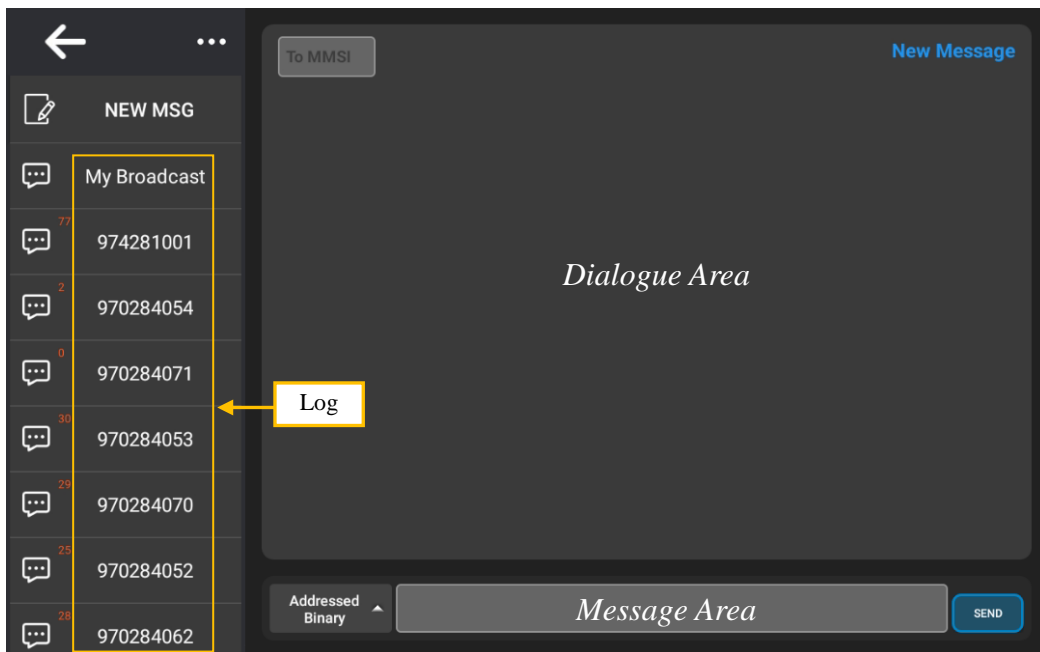

NAB-1000 MKD:

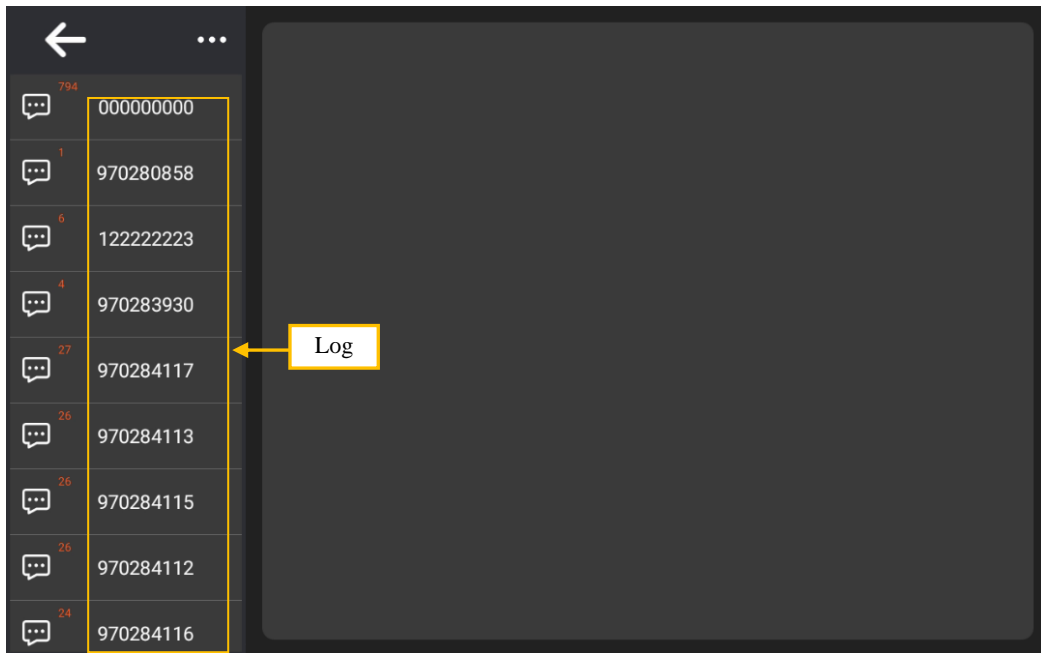

Note: For Class B AIS, sending AIS messages are not allowed.

- **NEW MSG (NSI-1000 MKD):** In **NEW MSG** item, you can edit and send message to other AIS. Choose the message type that you desire. If the type is “Addressed Binary” or “Addressed Safety”, it needs to input the MMSI, then edit the message and send. After sending out, a sent MMSI item appears to tell you the message has been sent. You can wait for the confirmation by another party in **Dialogue Area**. You can also check the log in the relevant MMSI item. The broadcast message sent can be viewed in **My Broadcast** item.

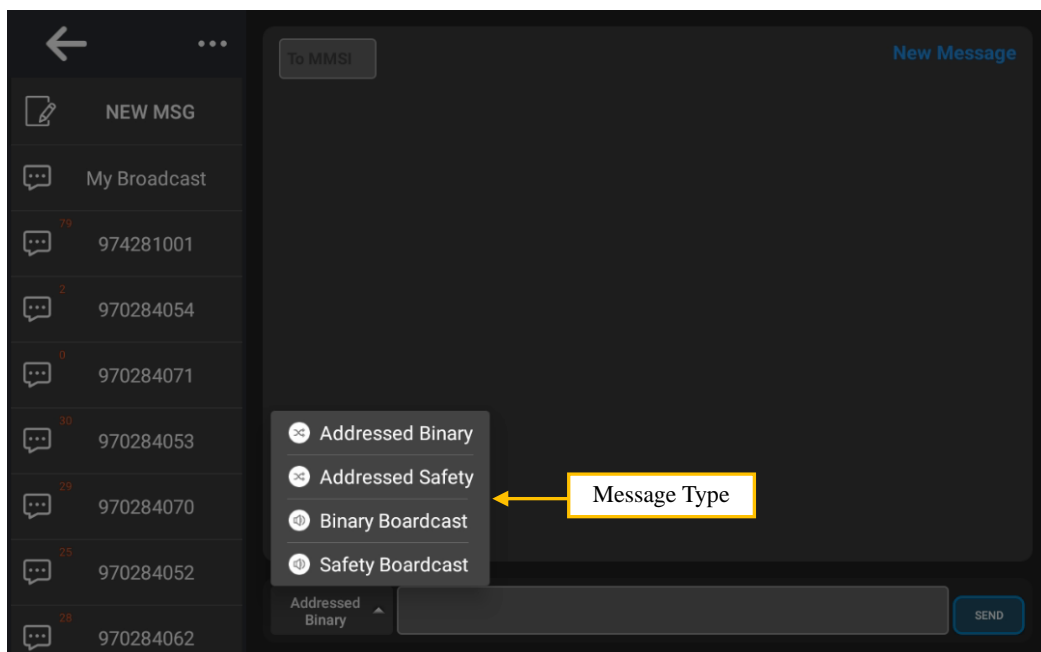

① For example, Message Type – **Addressed Binary**:

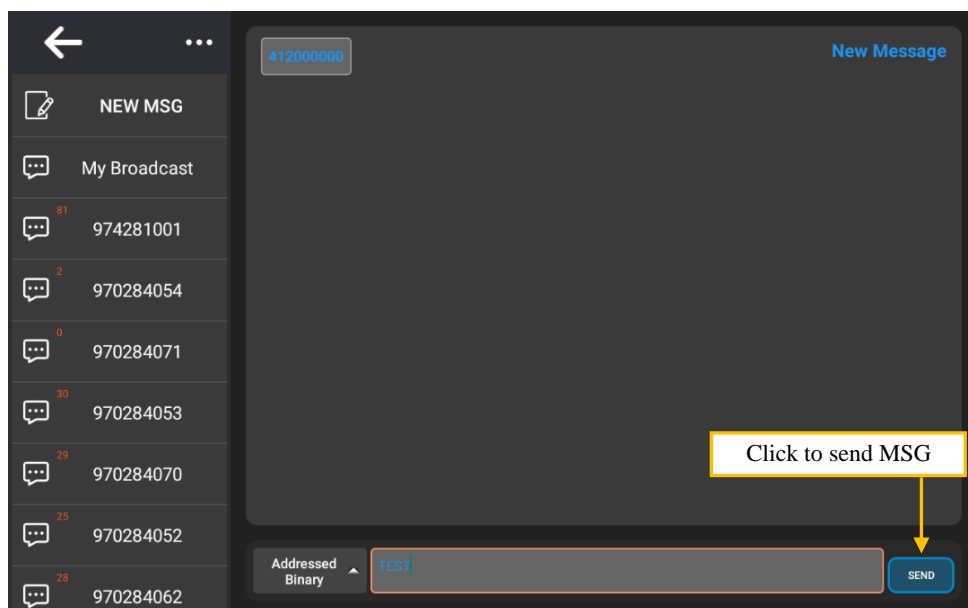
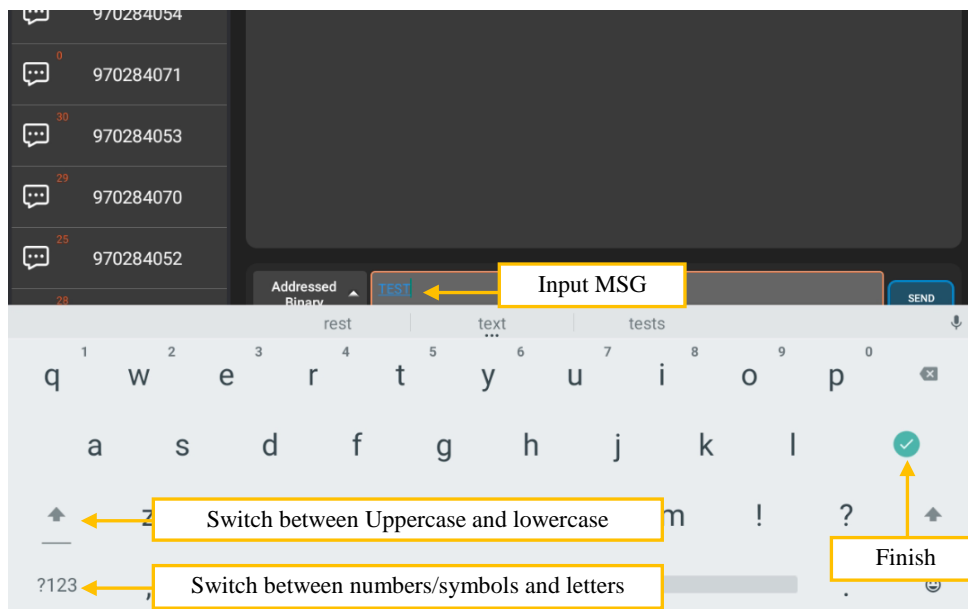

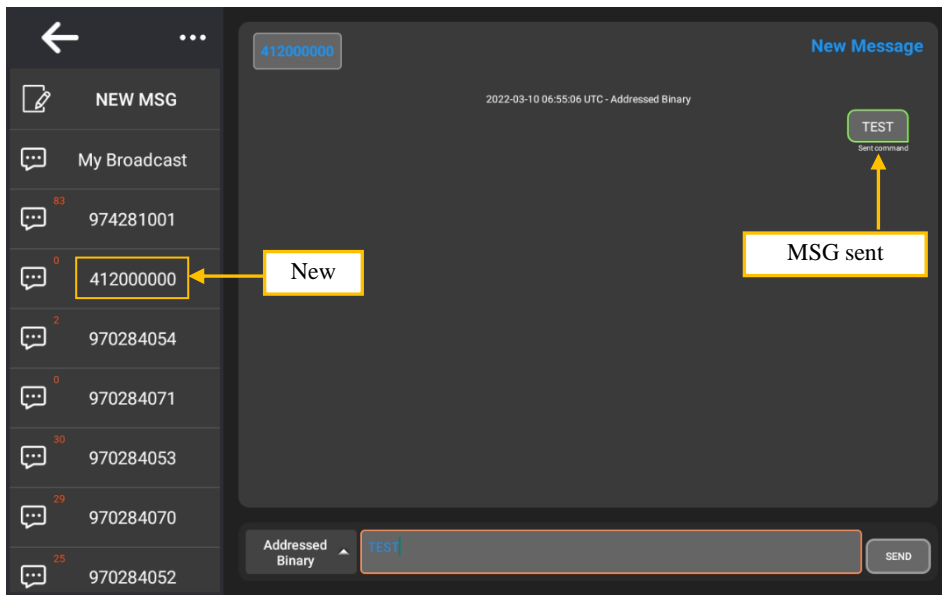

② For example, Message Type – **Binary Broadcast**:

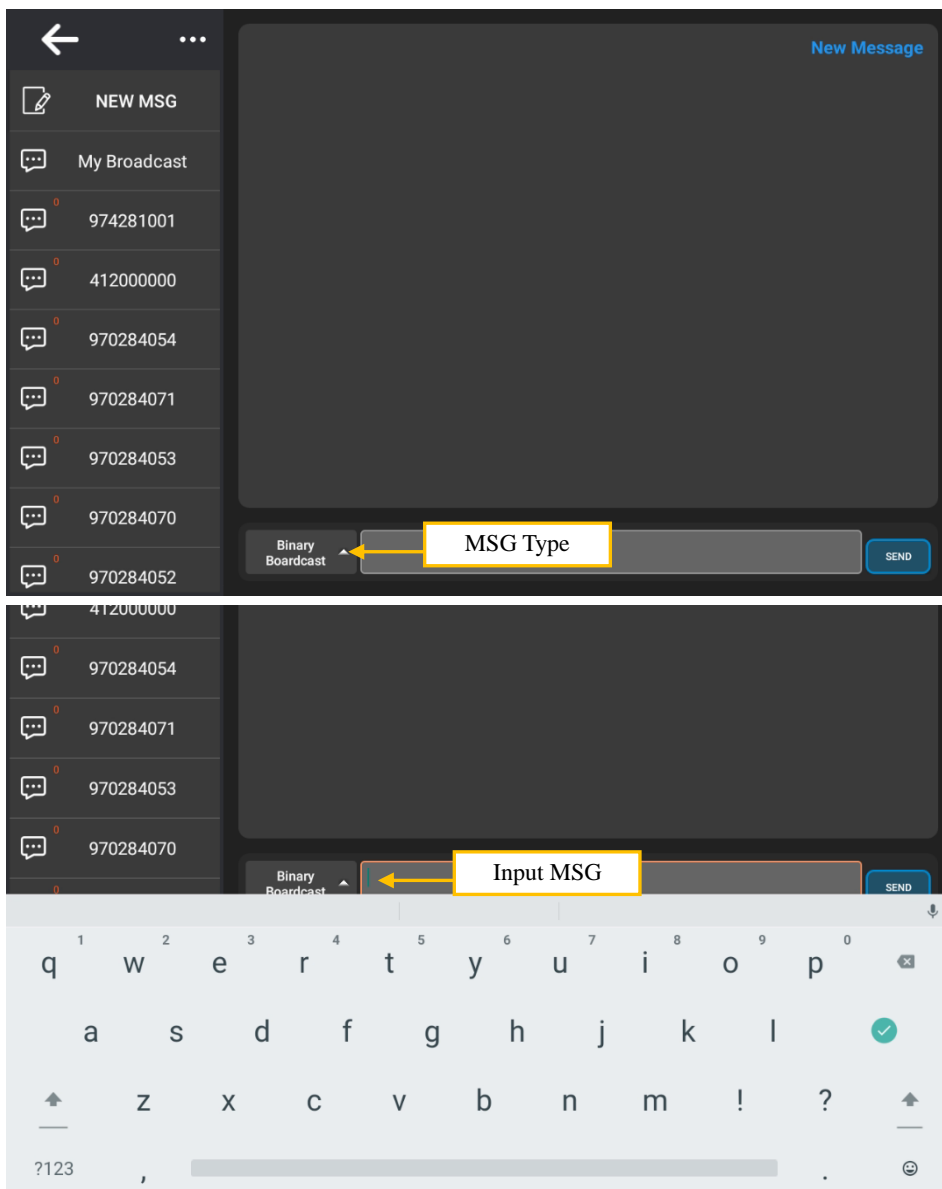

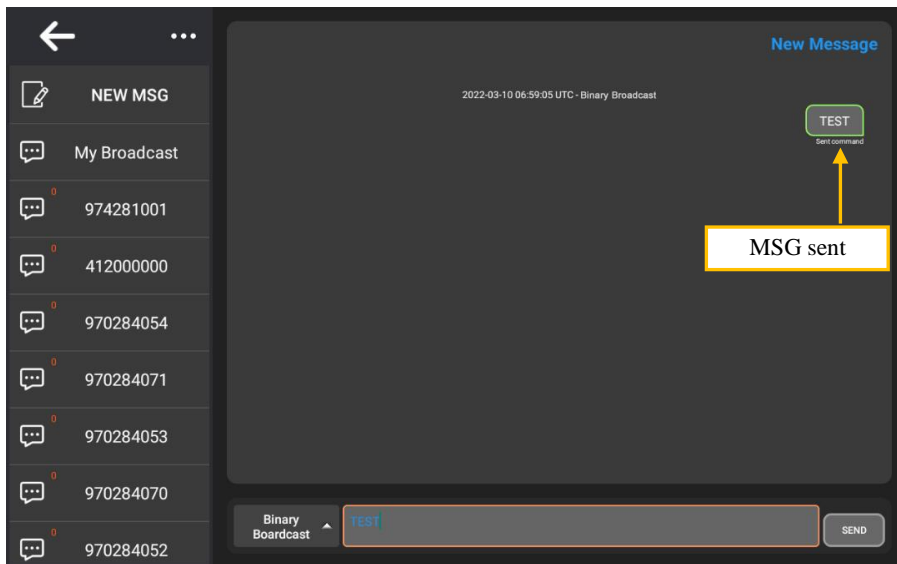
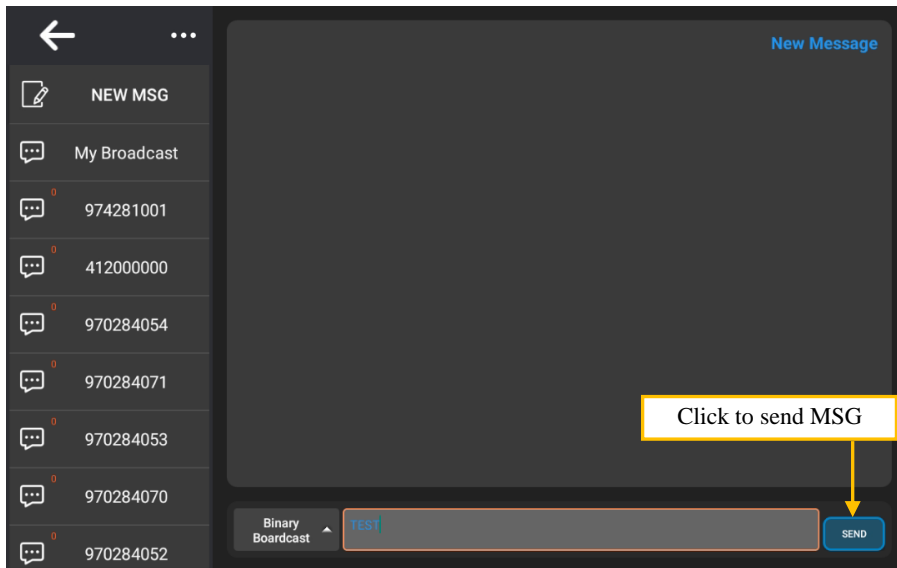

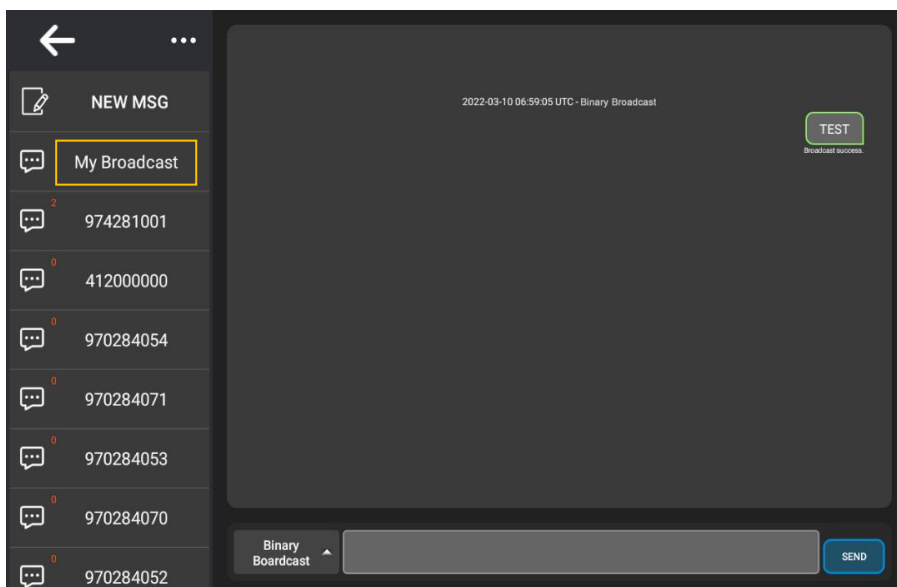

- **MSG LOG:** In **LOG** area, you can view the broadcast messages in **My Broadcast** item (**NSI-1000 MKD**) or other messages in its MMSI item. For example:

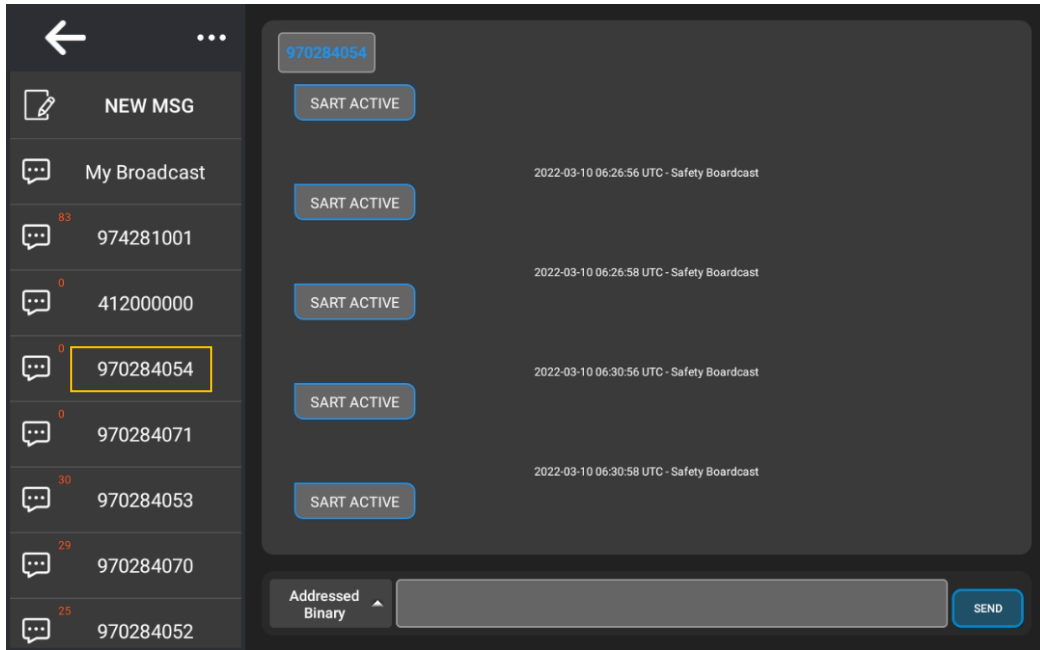



Click , then click . You can mark unread messages as all read, then the number of unread messages is cleared.

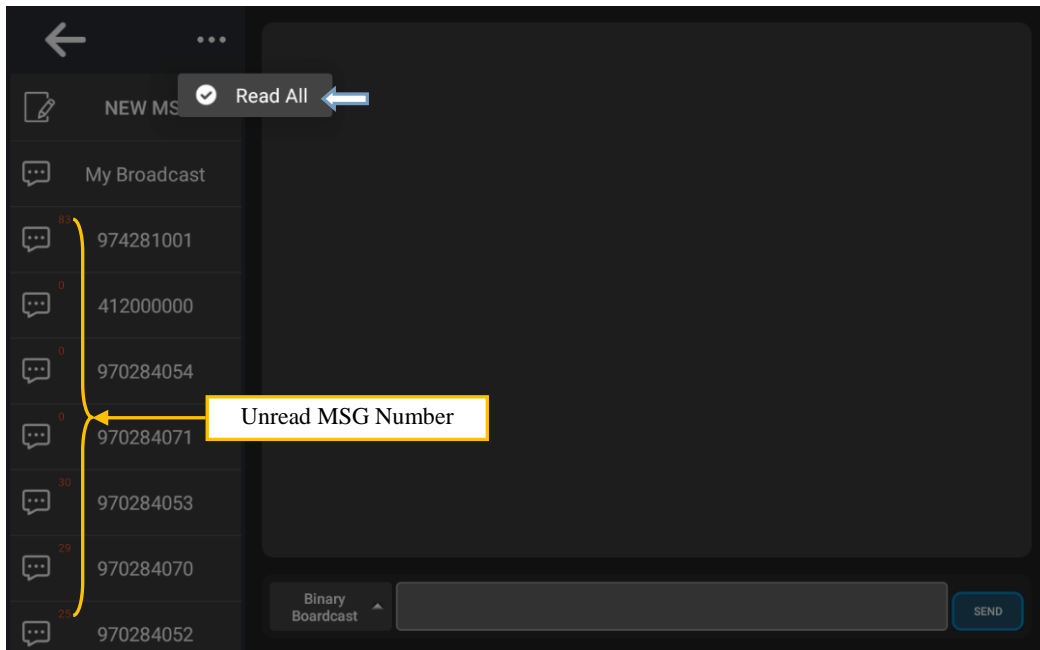

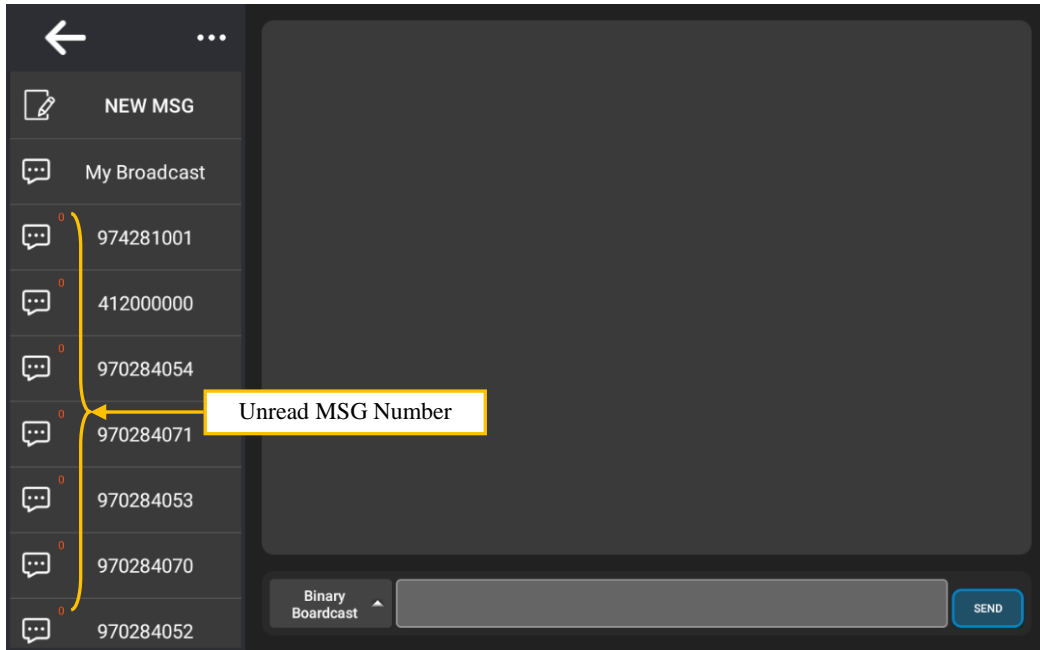

4.3.9 AIS DIAGNOTICS

Click  on main screen, the following [AIS DIAGNOTICS] screen appears:

NSI-1000 MKD:

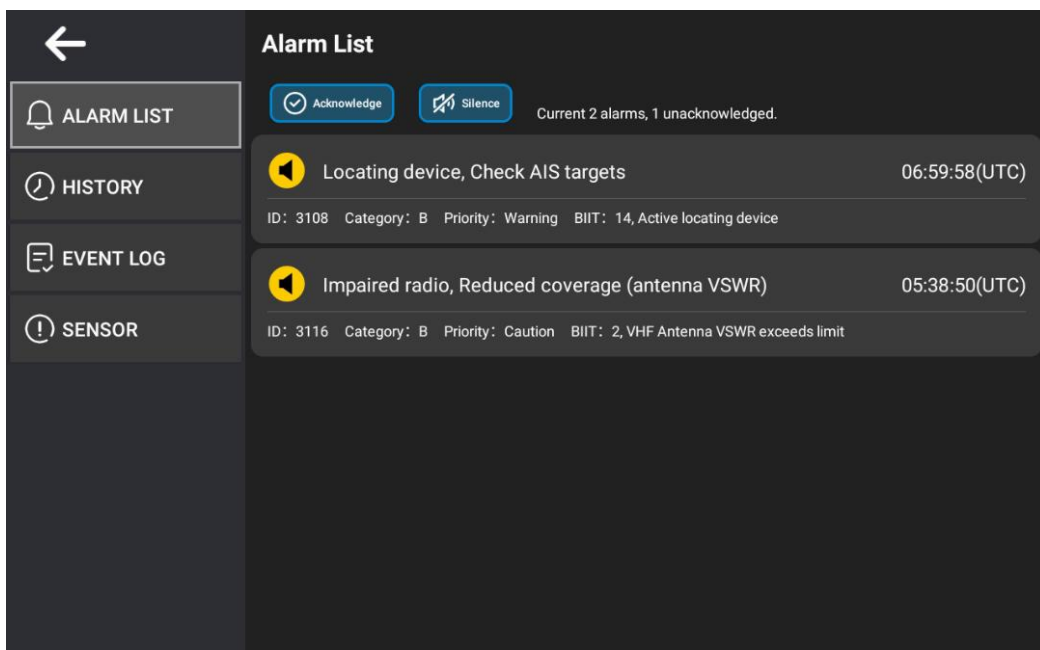



NAB-1000 MKD:

No	UTC Time	State
1	2022-03-11 06:29:19	Power ON
2	2021-10-20 06:58:06	Power OFF

4.3.9.1 ALARM LIST (NSI-1000 MKD)

In **Alarm List** (standard: IEC 62923-1), the alarm messages are listed with the time generated, whether acknowledged or not, and alarm contents. You can also see the both number of current and unacknowledged alarms.

Alarm Message	Time
Locating device, Check AIS targets ID: 3108 Category: B Priority: Warning BIIT: 14, Active locating device	06:59:58(UTC)
Impaired radio, Reduced coverage (antenna VSWR) ID: 3116 Category: B Priority: Caution BIIT: 2, VHF Antenna VSWR exceeds limit	05:38:50(UTC)

While  flashes, it means the alarm message is unacknowledged. You can click 

to acknowledge the alarm, or click  to mute the alarm.

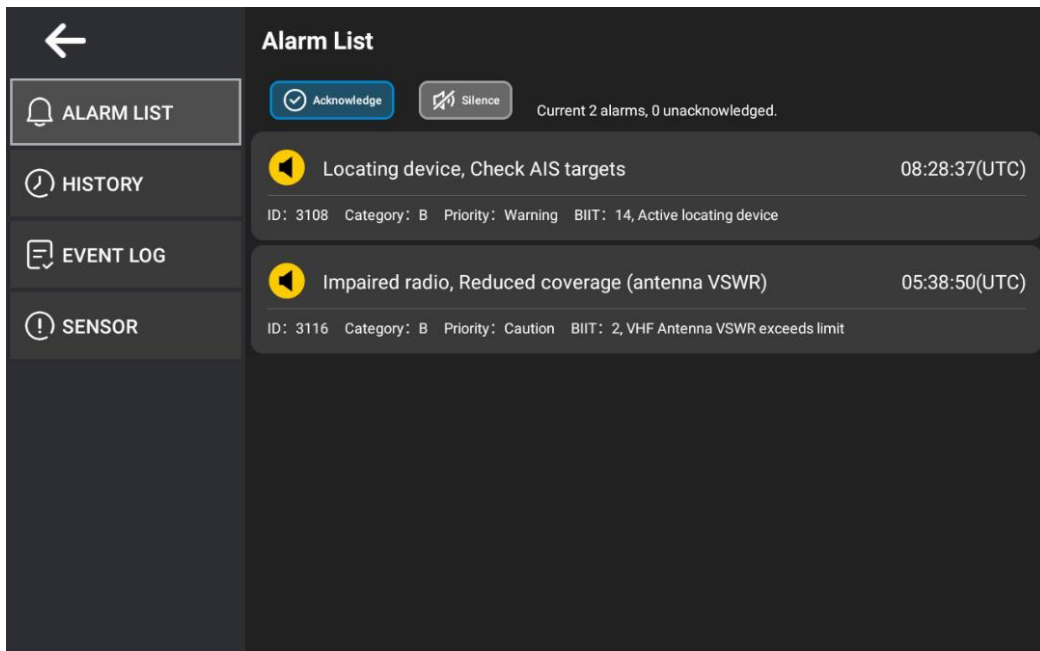

4.3.9.2 ALARM HISTORY (NSI-1000 MKD)

In **HISTORY** item, you can check the alarm history as below:

No	Time	ID	BIIT	State	Description
1	08:28:37(UTC)	3108	14	A	Locating device
2	05:38:50(UTC)	3116	2	A	Impaired radio
3	06:59:58(UTC)	3108	14	V	Locating device
4	05:38:50(UTC)	3116	2	A	Impaired radio
5	06:33:55(UTC)	3108	14	V	Locating device

4.3.9.3 EVENT LOG

In **EVENT LOG** item, the last 100 AIS events will be recorded, such as Power OFF for more than 15 minutes, Silence ON for more than 15 minutes, Power ON, Silence OFF, etc.

Note: The date/time is based on UTC time.

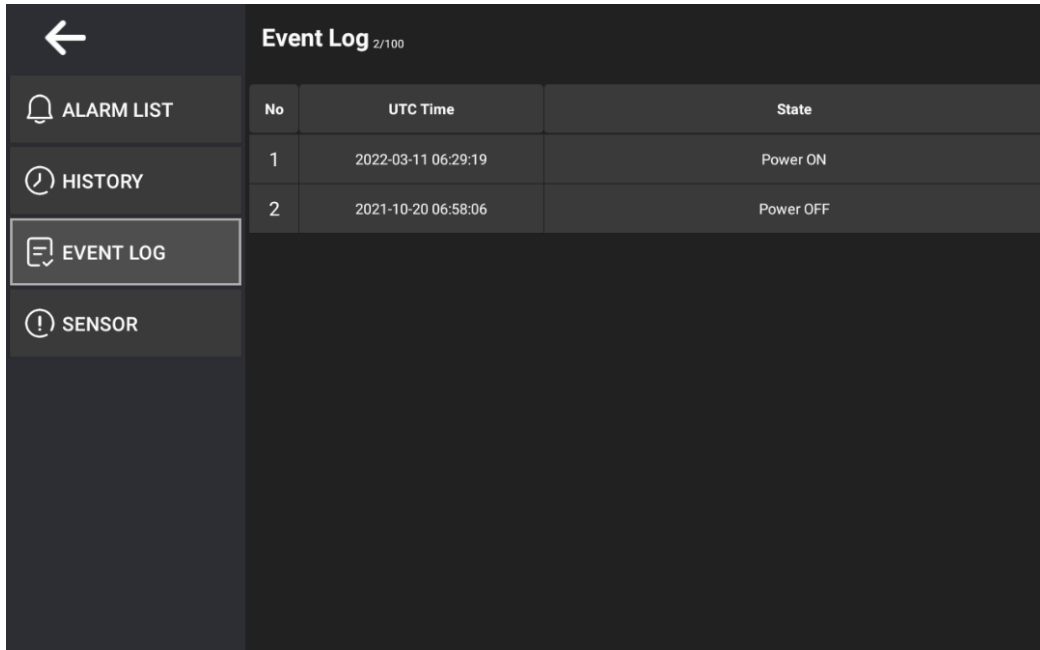

No	UTC Time	State
1	2022-03-11 06:29:19	Power ON
2	2021-10-20 06:58:06	Power OFF

4.3.9.4 SENSOR STATUS (NSI-1000 MKD)

Check the current sensor status.

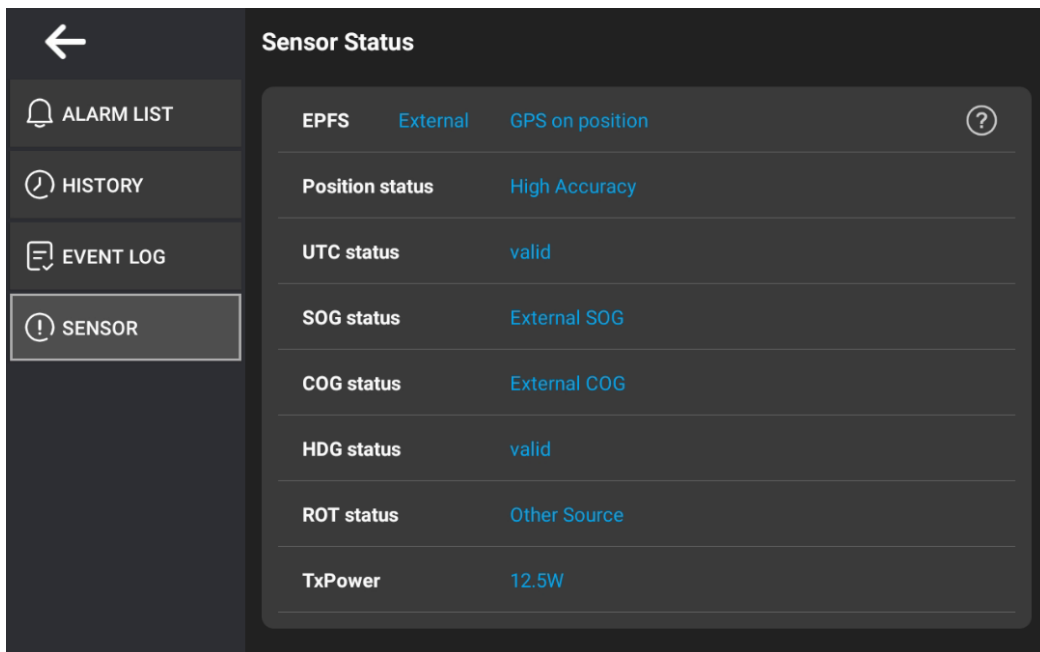

EPFS	External	GPS on position	
Position status	High Accuracy		
UTC status	valid		
SOG status	External SOG		
COG status	External COG		
HDG status	valid		
ROT status	Other Source		
TxPower	12.5W		

5. SETTING

Click  on main screen, the following [SETTING] screen appears:

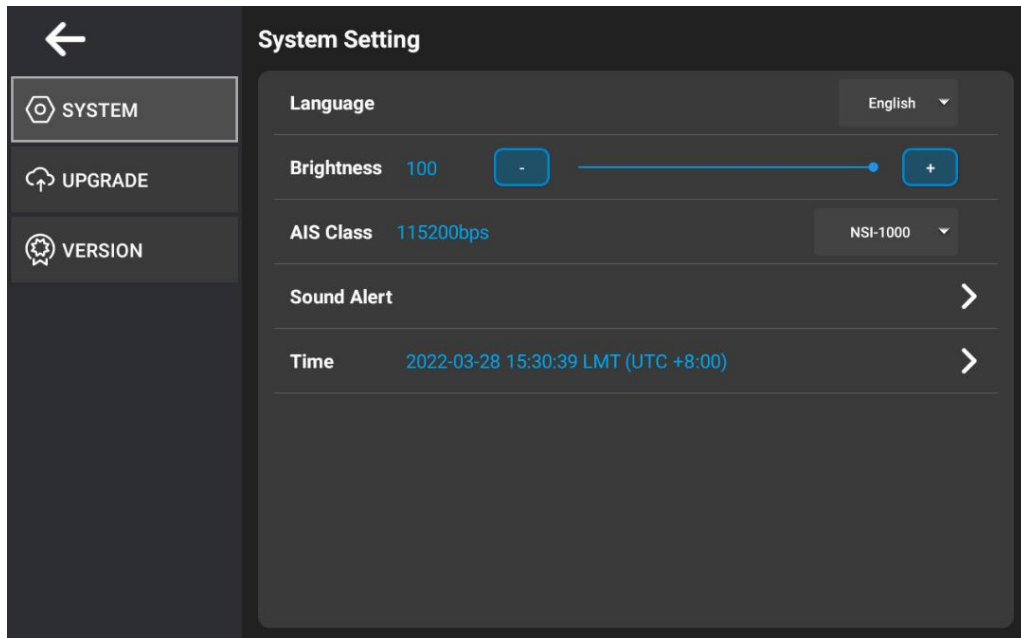



5.1 SYSTEM SETTING

Click . [System Setting] menu includes following items.

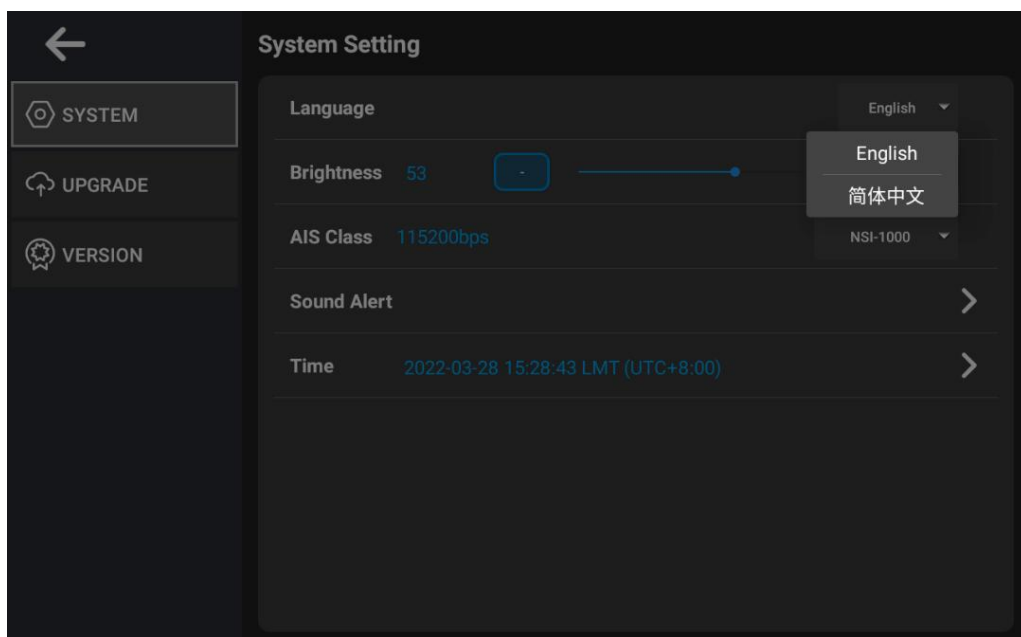
- **Language:** Select the language to be used.



- **Brightness:** Slide the blue dot left or right, or click  /  to adjust the brightness.
- **AIS Class:** Values are “NAB-1000, NSI-1000, Other AIS, No AIS”. AIS type NSI-1000 or NAB-1000 as default.

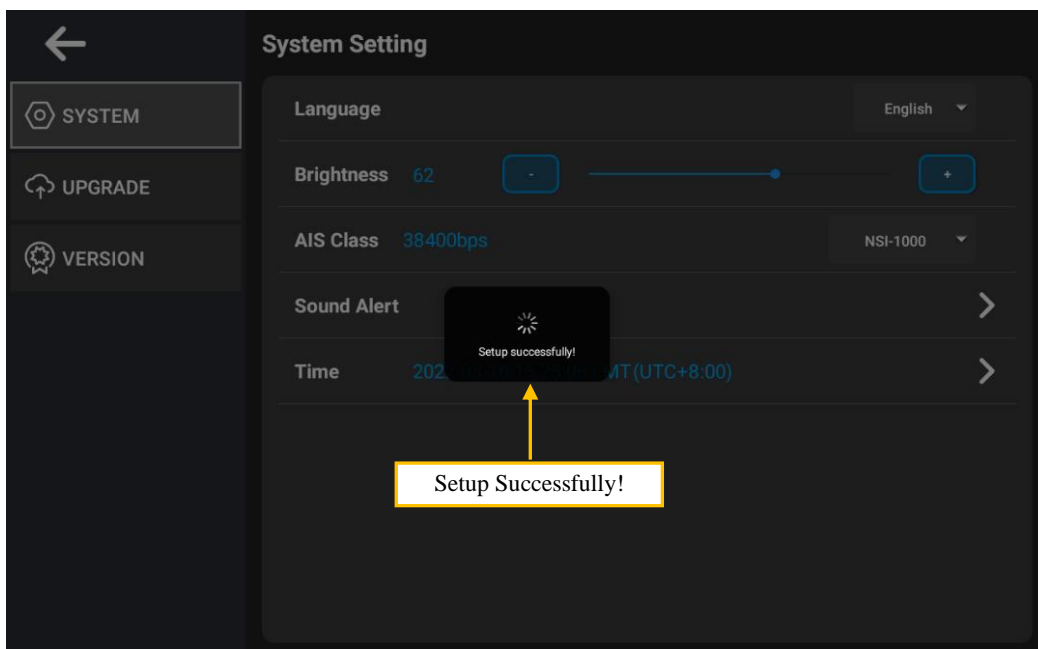
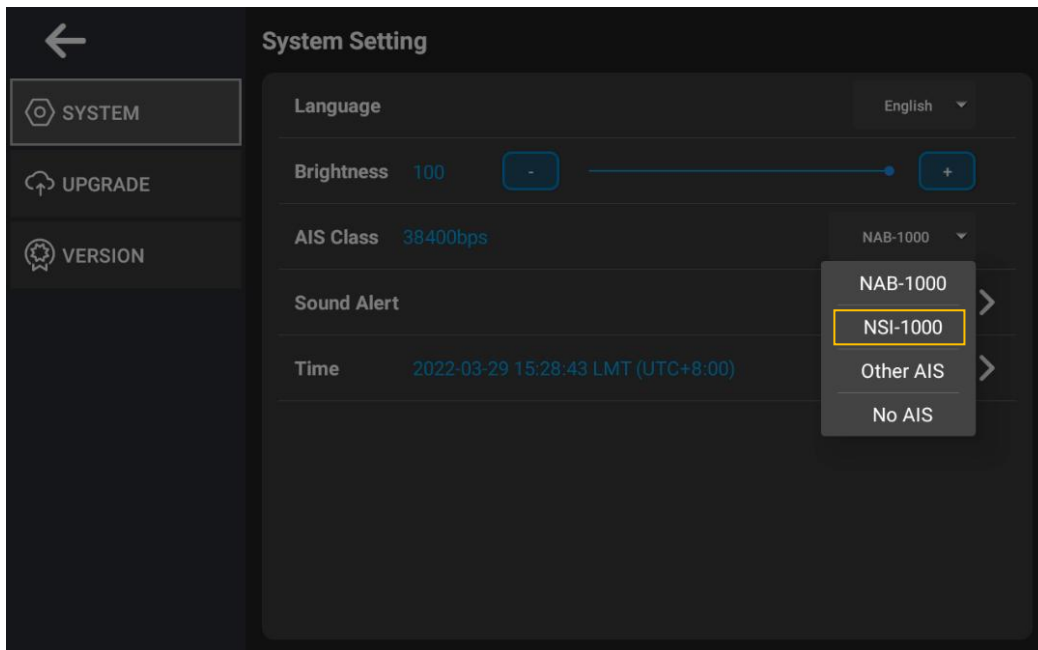

Note: **NAB-1000** – NAB-1000 MKD; **NSI-1000** – NSI-1000 MKD; **Other AIS** – Other AIS MKD; **No AIS** – Standalone GNSS plotter.

For example, set **AIS Class** to NSI-1000, and wait until “Setup Successfully!” appears:



Note:

The baud rate between NSI-1000 transponder and MKD: 115200bps
 The baud rate between NAB-1000 transponder and MKD: 38400bps
 Both interfaces are in RS232.

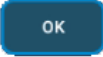
- **Sound Alert:** “” (enable the sound) or “” (mute the sound), default is “”; Click  to confirm the setting.

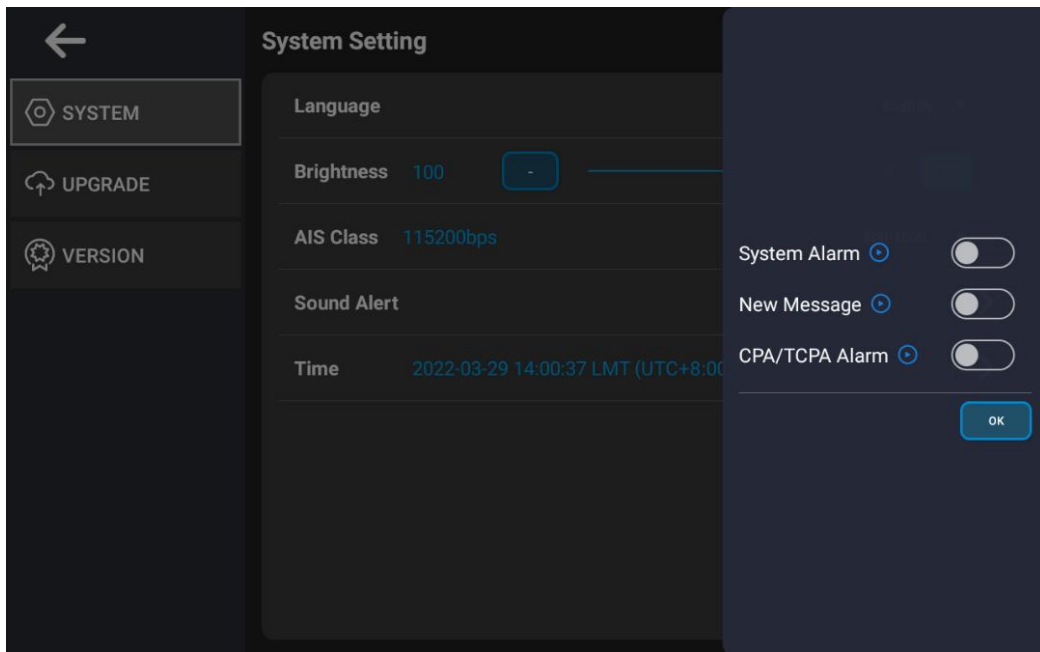

Click  to identify each sound.

- **Time:** The displayed time can be selected between **UTC** and **LMT**.

After setting, the upper left corner of the chart displays UTC/LMT time accordingly.

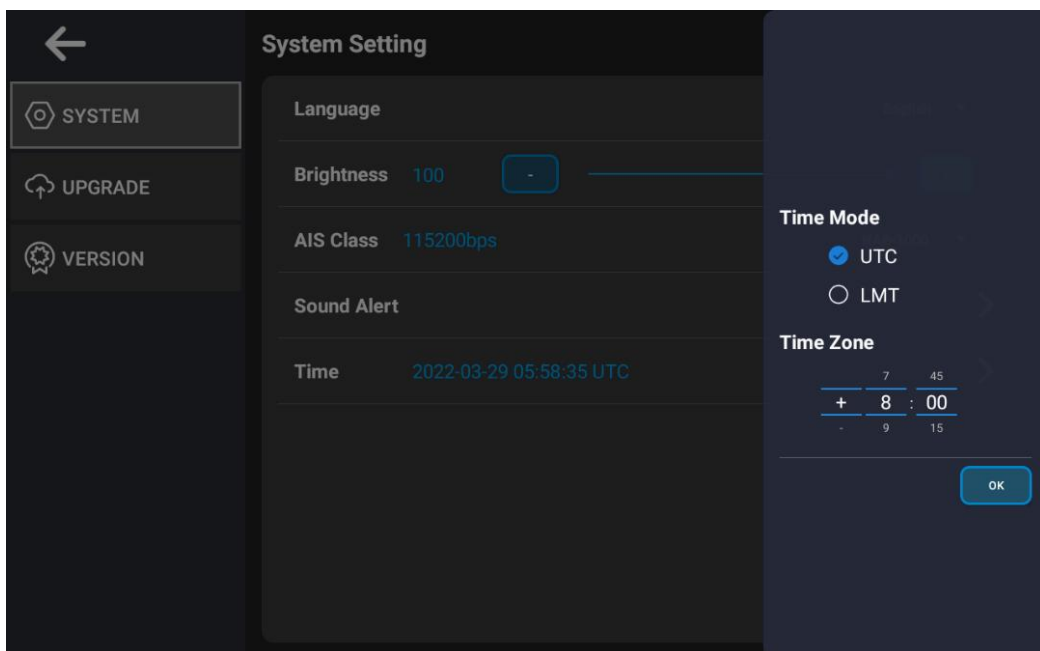

In LMT, time zone can be selected.

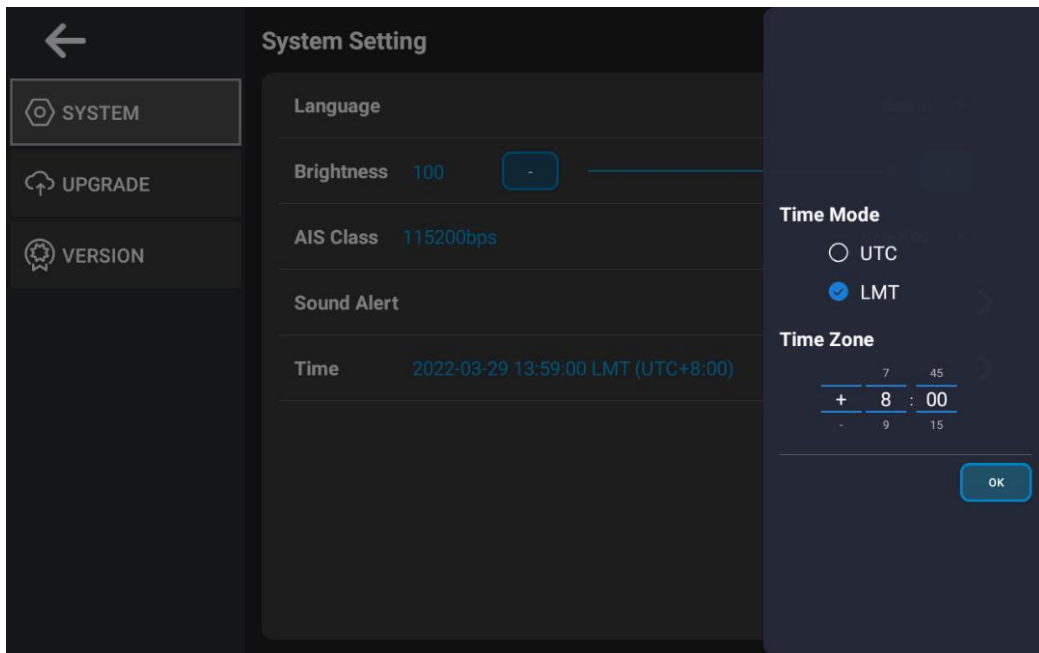



5.2 SOFTWARE UPGRADE

The procedure of software upgrading is as follows:

- ① Contact NSR or the authorized dealer for latest firmware. Copy it to the root directory of the USB disk and change the name as “update.apk”.
- ② Insert the USB disk into the USB port on the back of the plotter, then click  **UPGRADE** . The equipment will automatically detect the disk and install the software package step by step.
- ③ After installation, the APP will restart automatically. And you can view the MKD version to check whether the upgrading is successful. For example:

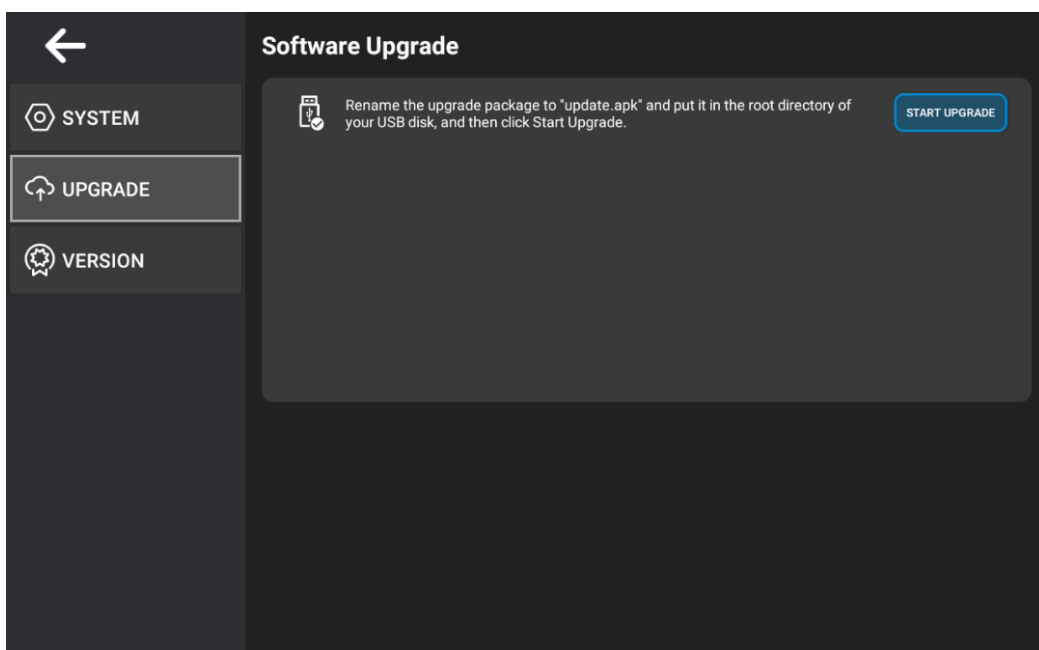

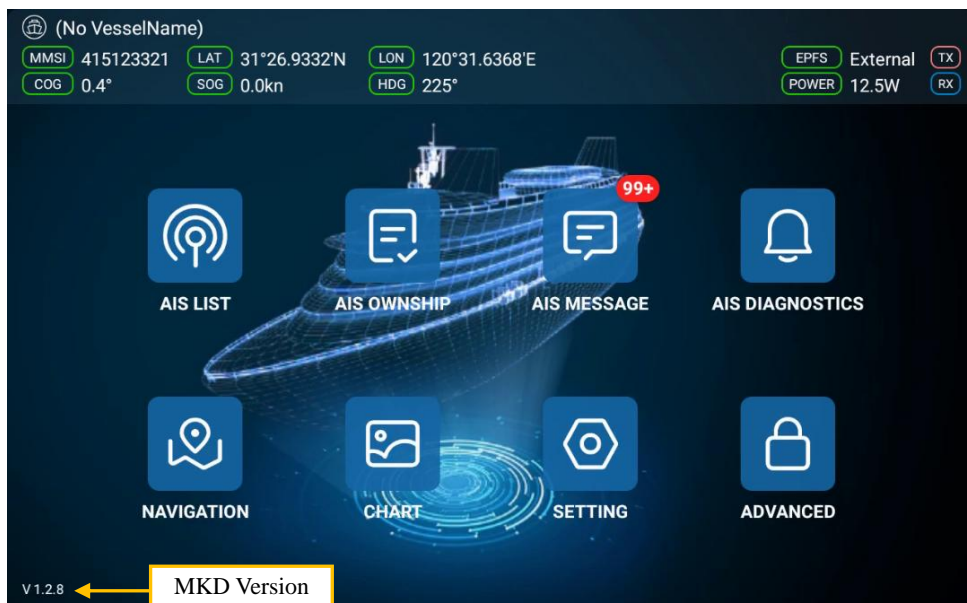
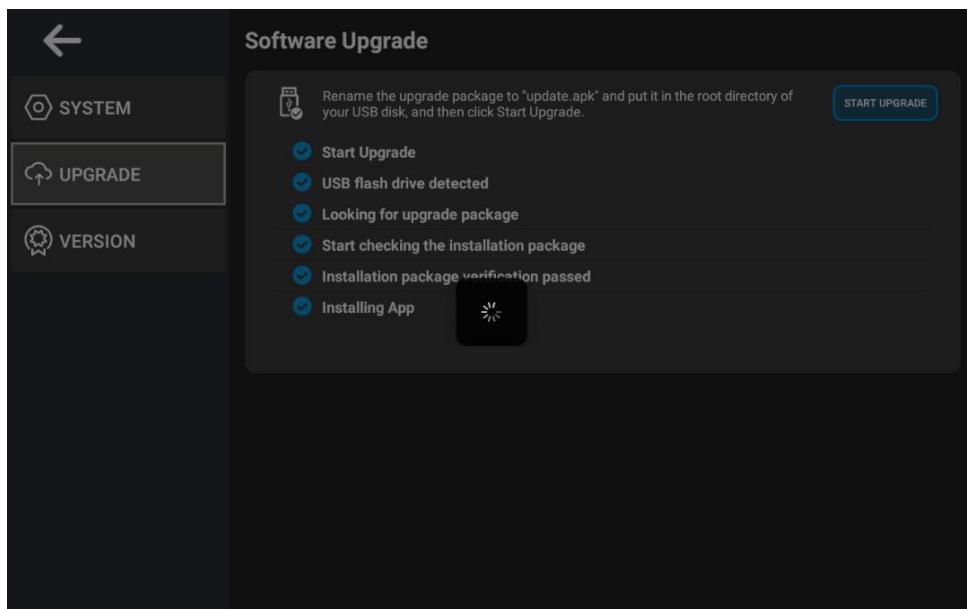
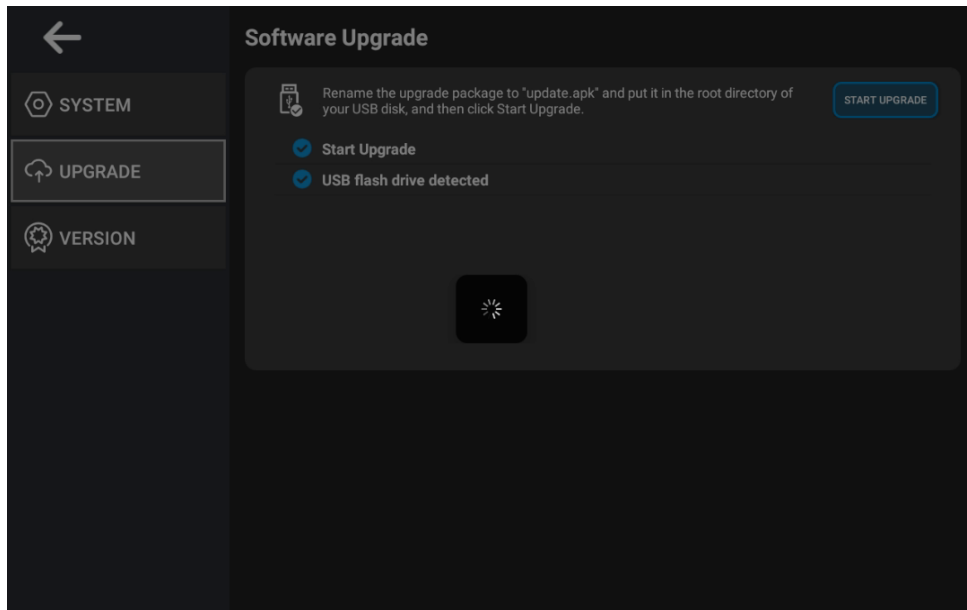

Error information and Suggestion in Upgrading

Error Information	Suggestion
System Error1	Restart the plotter and try to upgrade again.
System Error2	Restart the plotter and try to upgrade again.
No USB flash drive detected	Re-insert the USB disk or try another one.
Installation package does not exist	Check the upgrade software, which should be named as “update.apk” in the root directory of the USB disk.
Installation package verification did not pass	Please get the upgrading software from NSR or its authorized dealer.
Failed to install	Try to upgrade again or restart the plotter.
Unknown error	Try to upgrade again or restart the plotter.

5.3 VERSION

From [SETTING] screen, click  VERSION. You can check MKD Version / TX Version / Kernel Version / SDK Version / rDB Version as below:

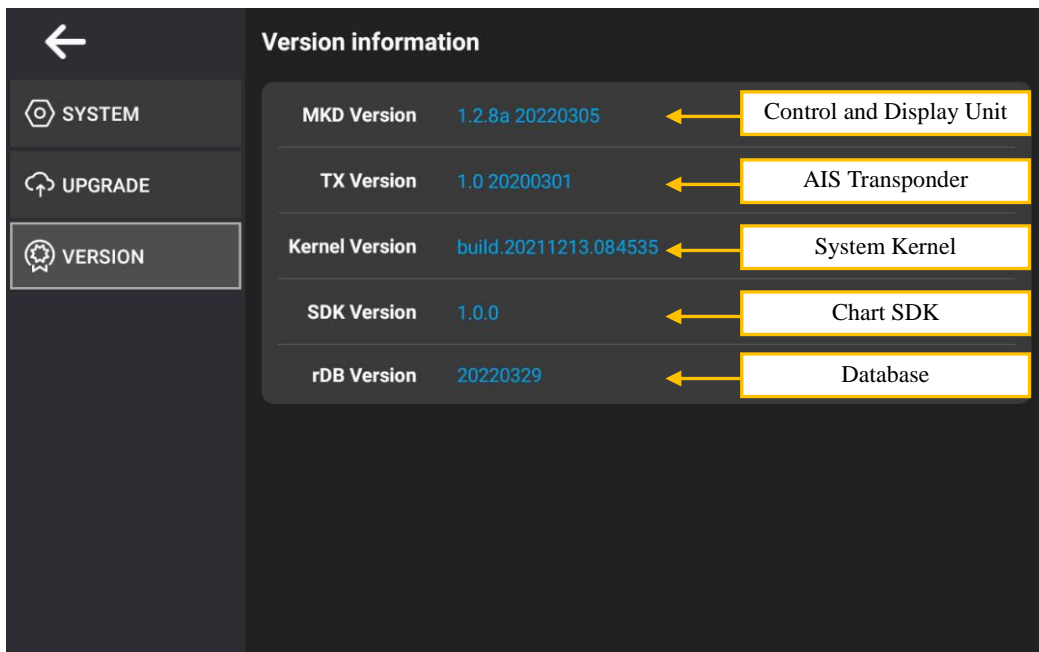

6. ADVANCED



Click on main screen, then the following [ADVANCED] screen appears:



It's only used for service technician when the equipment is installed. Password is required to access the submenu.

6.1 COM MONITOR

It's to check the communication sentences on the I/O ports.

NSI-1000 MKD:

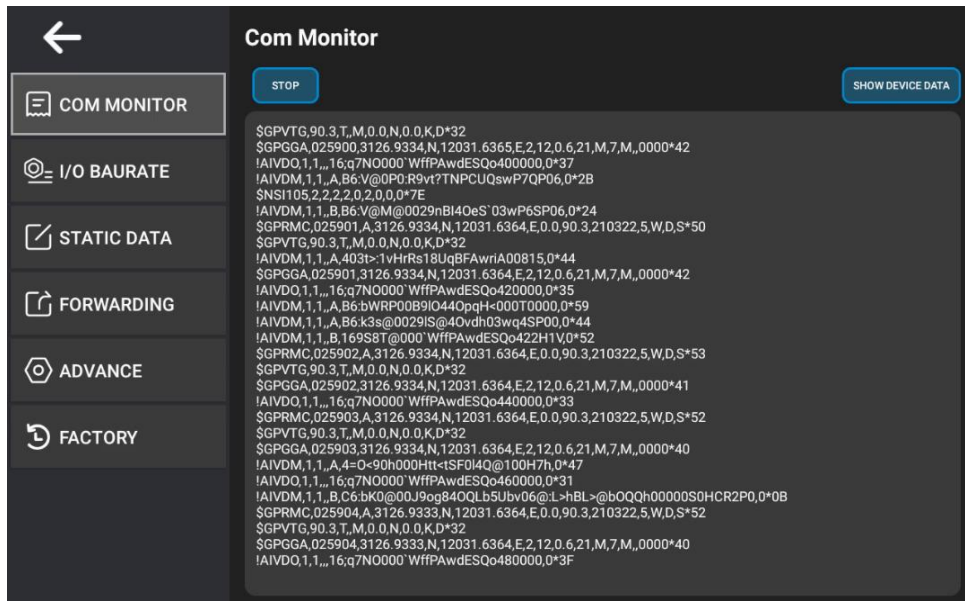

- **STOP** / **START** : Stop/start monitoring.
- **SHOW DEVICE DATA** : All details of NSI-1000 are output to the text view. For example:

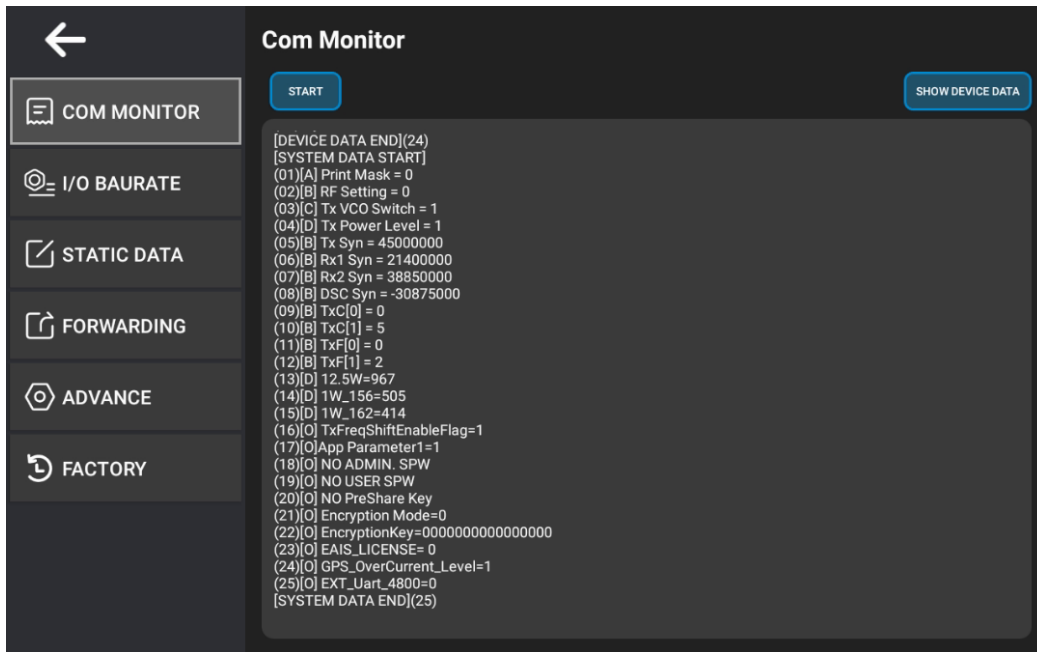

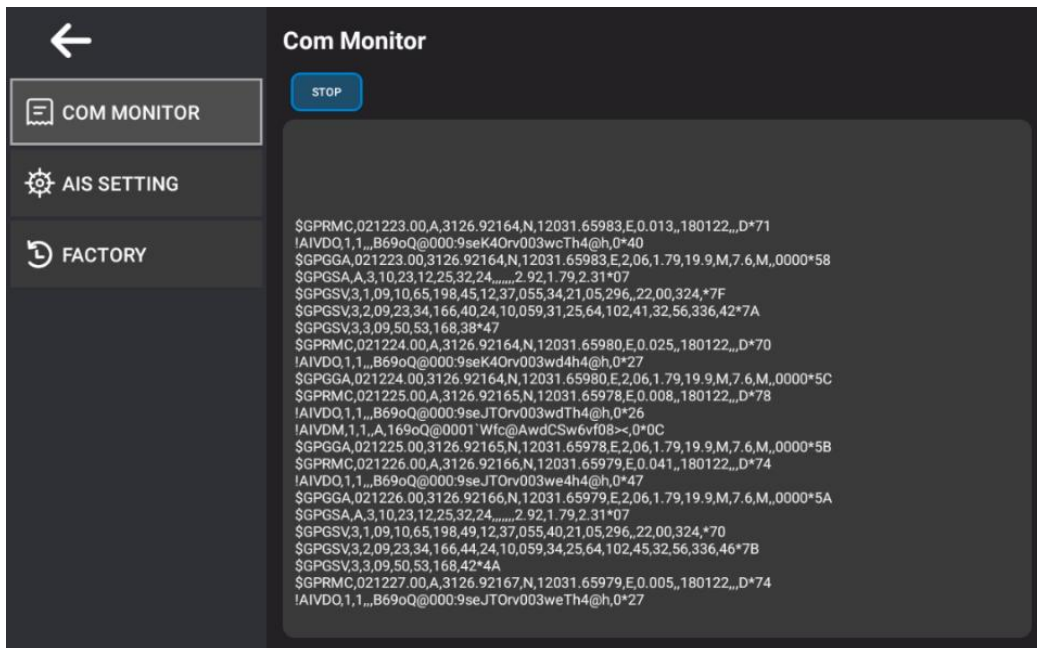

NAB-1000 MKD:

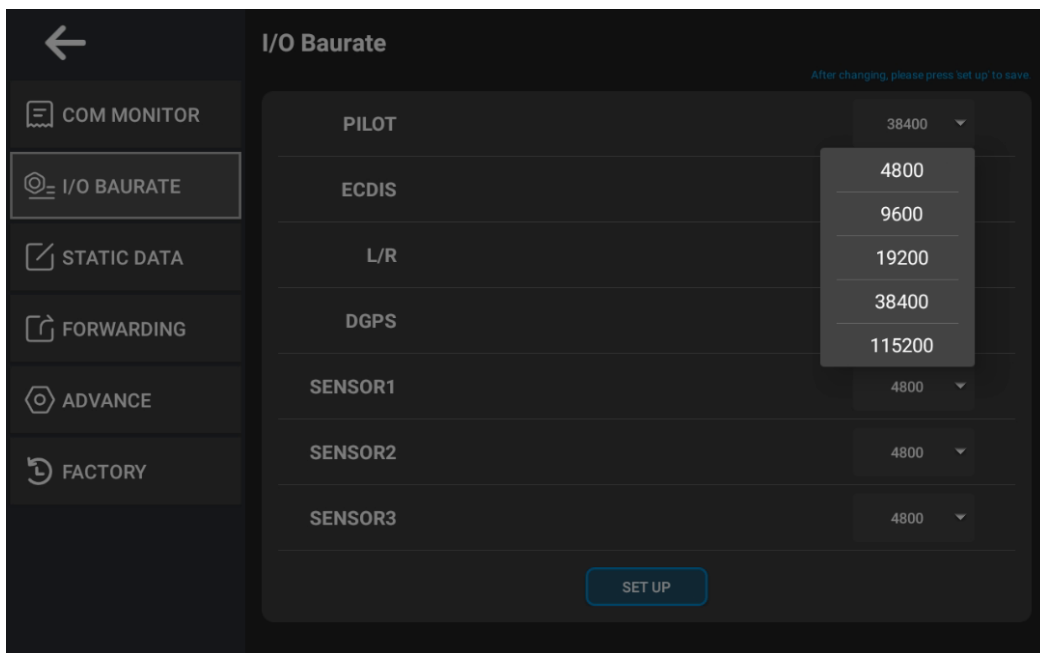
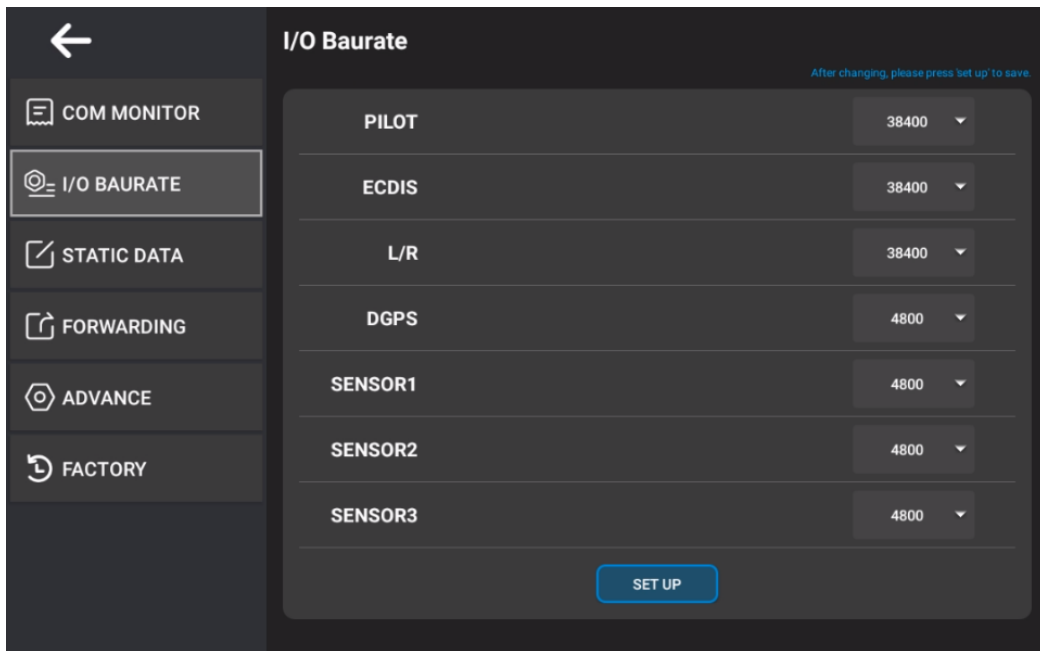

6.2 I/O BAUDRATE (NSI-1000 MKD)

The baud rate for each sensor and output (PILOT/ECDIS/L/R etc.) can be chosen among 4800 / 9600 / 19200 / 38400/ 115200bps.



Note: After changing, please click  to save and wait for the result of communication with NSI-1000. Please refer to **Section 8.3**.

6.3 STATIC DATA SETTING

NSI-1000 MKD:

In **STATIC DATA** item, own ship static data include **MMSI, Vessel Name, Call Sign, IMO No.** etc.

Click  to change the data,  to confirm the setting.

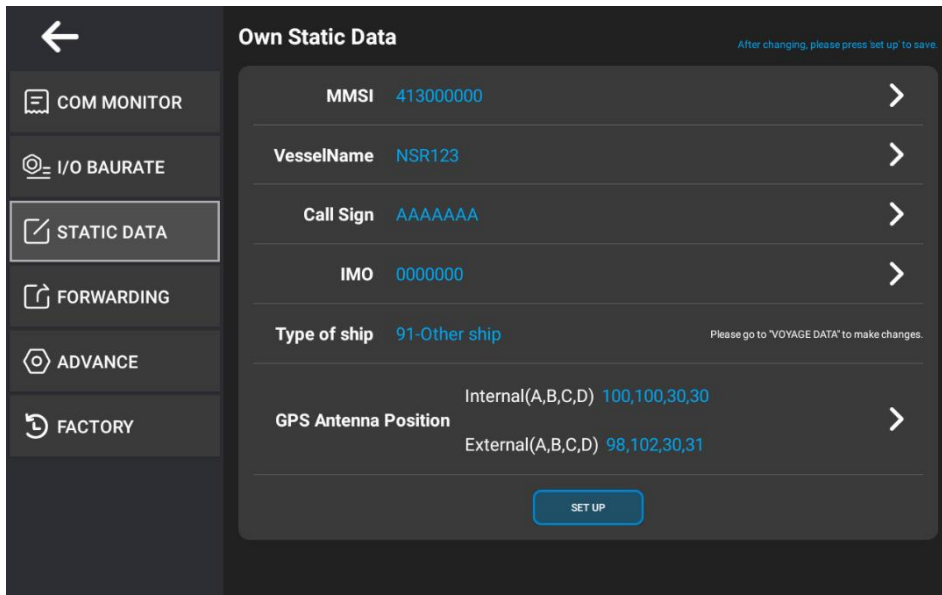

For example, **MMSI** setting and **GPS Antenna Position** setting:

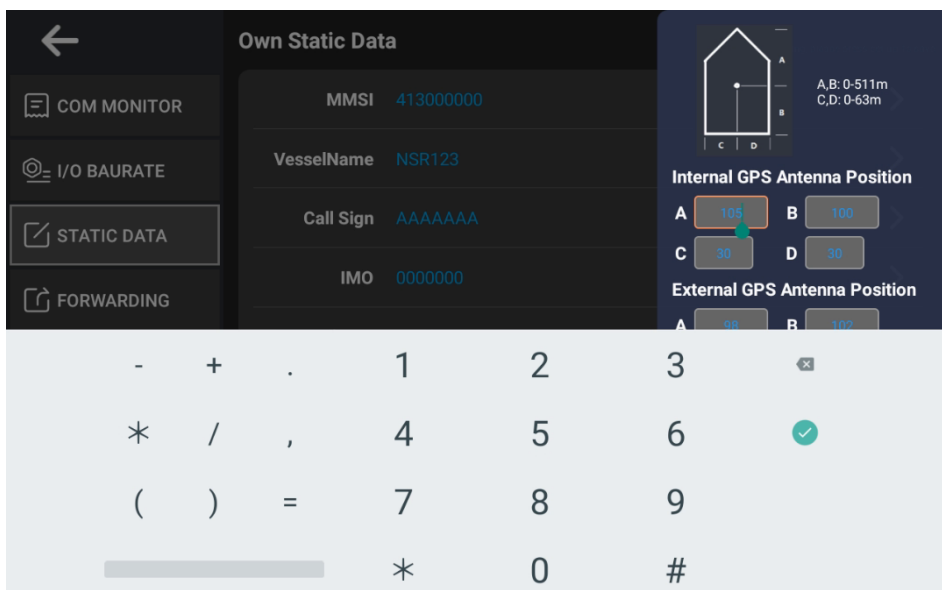
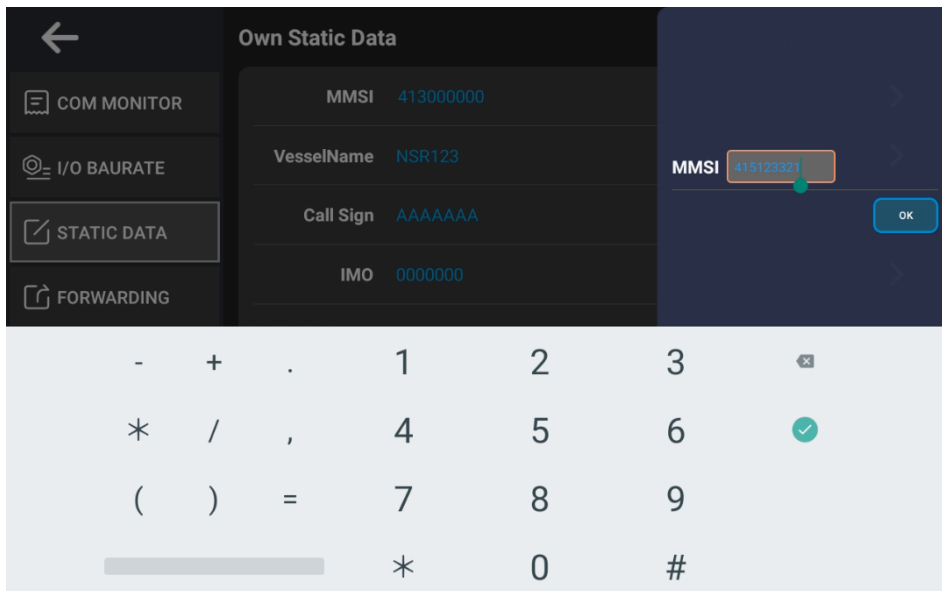

Note:

1. For **Type of Ship**, please go to **[OWN SHIP] - [VOYAGE DATA]** to make change and refer to **[Appendix 3: LIST OF SHIP TYPE]**.
2. After changing, please click  to save and wait for the result of communication with NSI-1000. Please refer to **Section 8.3**.

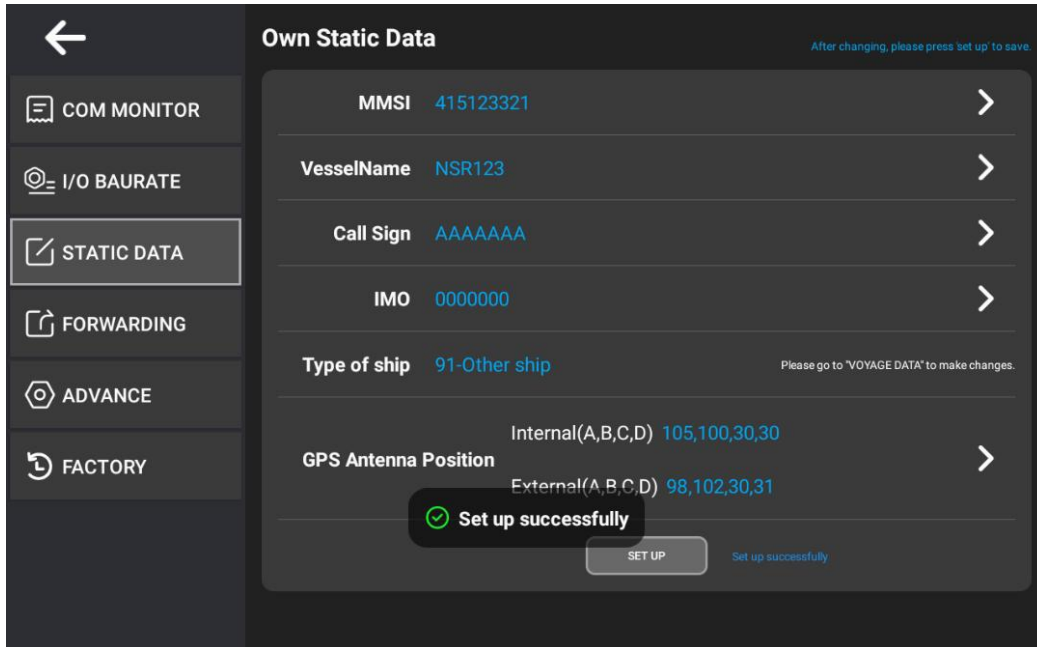

NAB-1000 MKD:

In **AIS SETTING** item, you can set own static data as below. The operation is similar to **NSI-1000 MKD**.

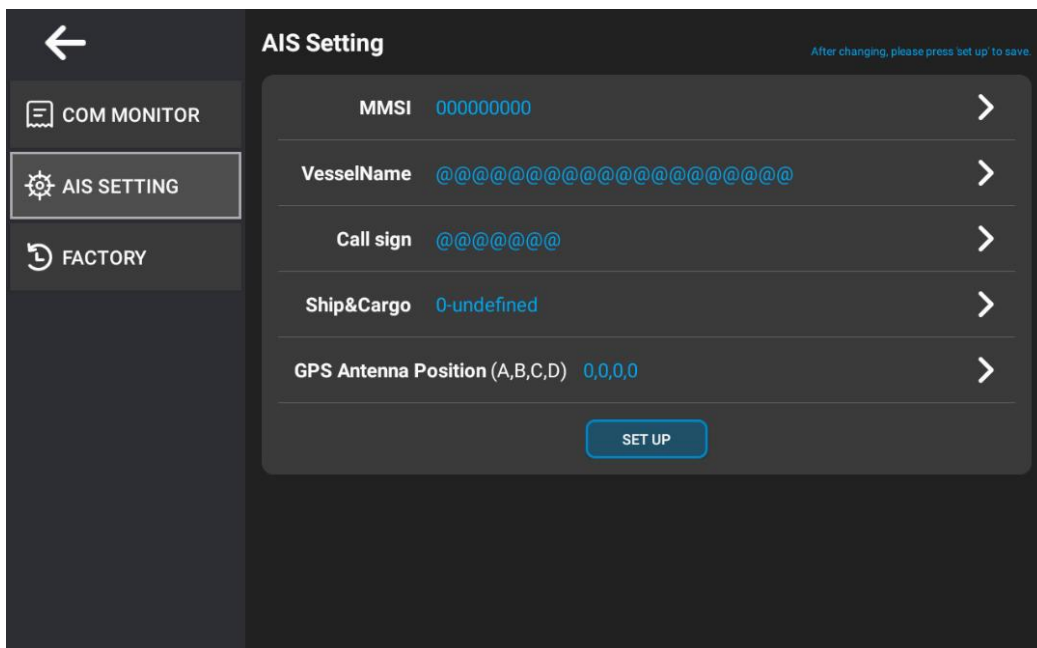

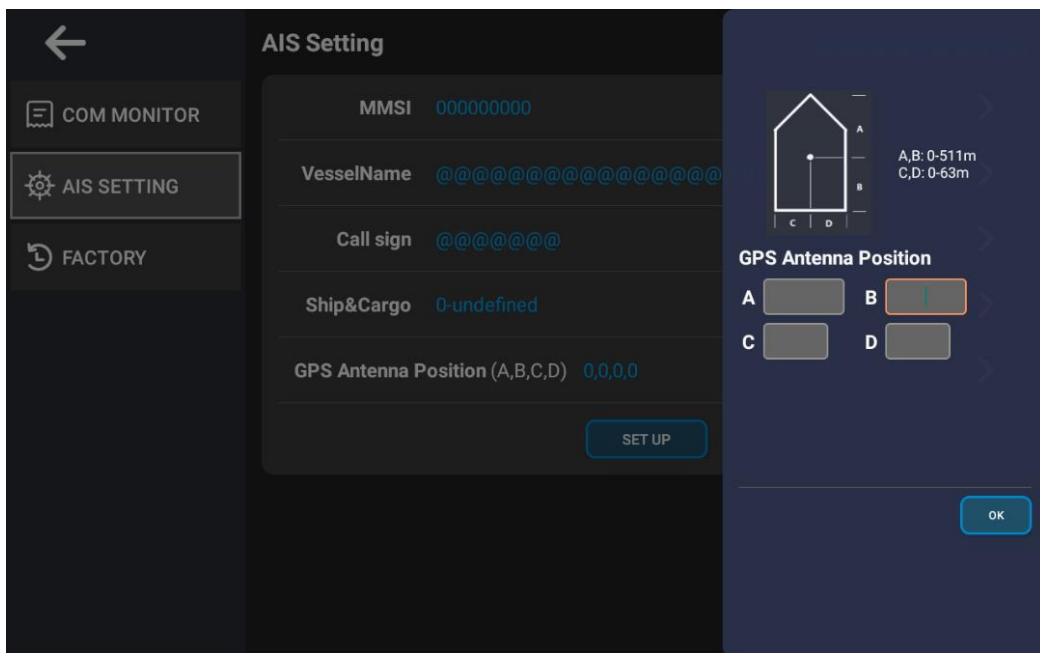
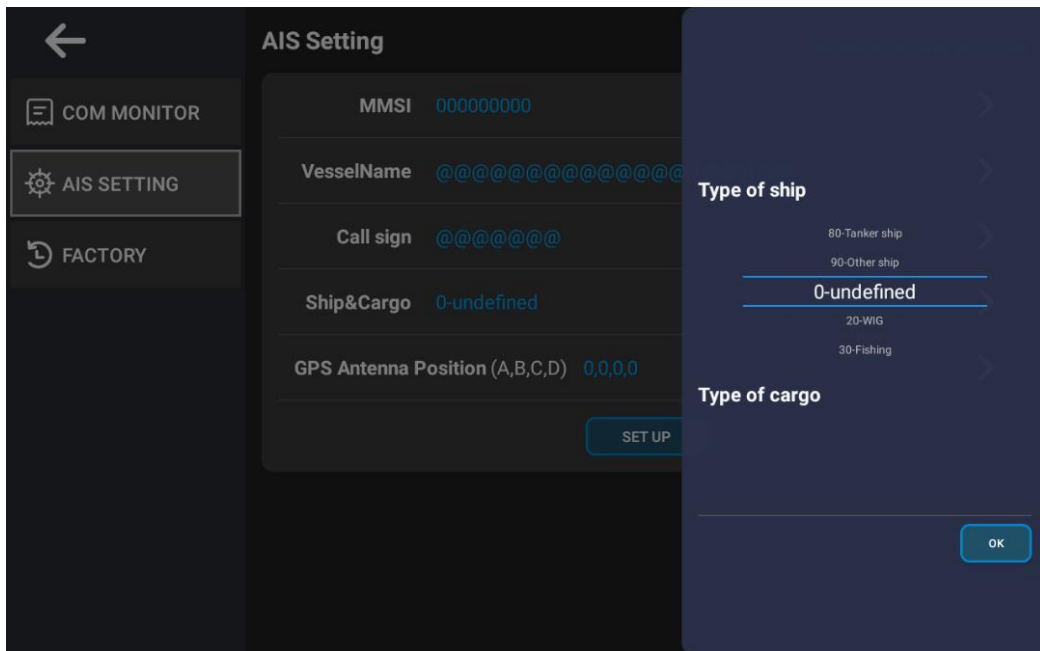

Note: After changing, please click  to save and wait for the result of communication with NAB-1000. Please refer to **Section 8.3**.

6.4 FORWARDING (NSI-1000 MKD)

If other sentences, besides normal VDM, need outputting from NSI-1000, setting in **FORWARDING** is needed.

ALARM, GPS, HDT and OTHER sentences can be selected individually or all together.

Note: After changing, please click  to save and wait for the result of communication with NSI-1000. Please refer to **Section 8.3**.

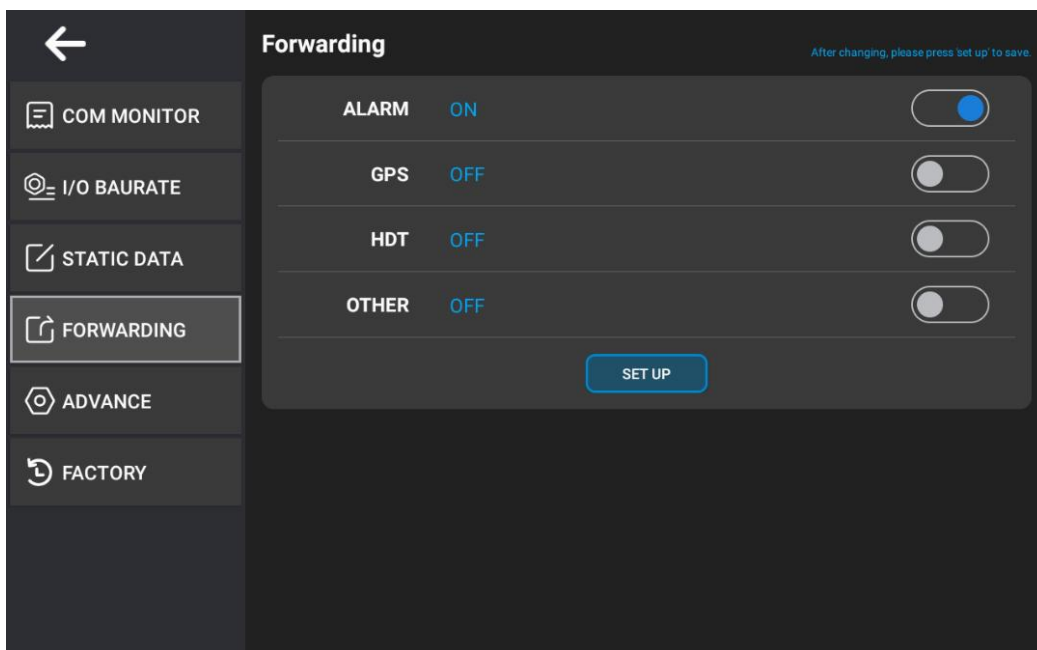
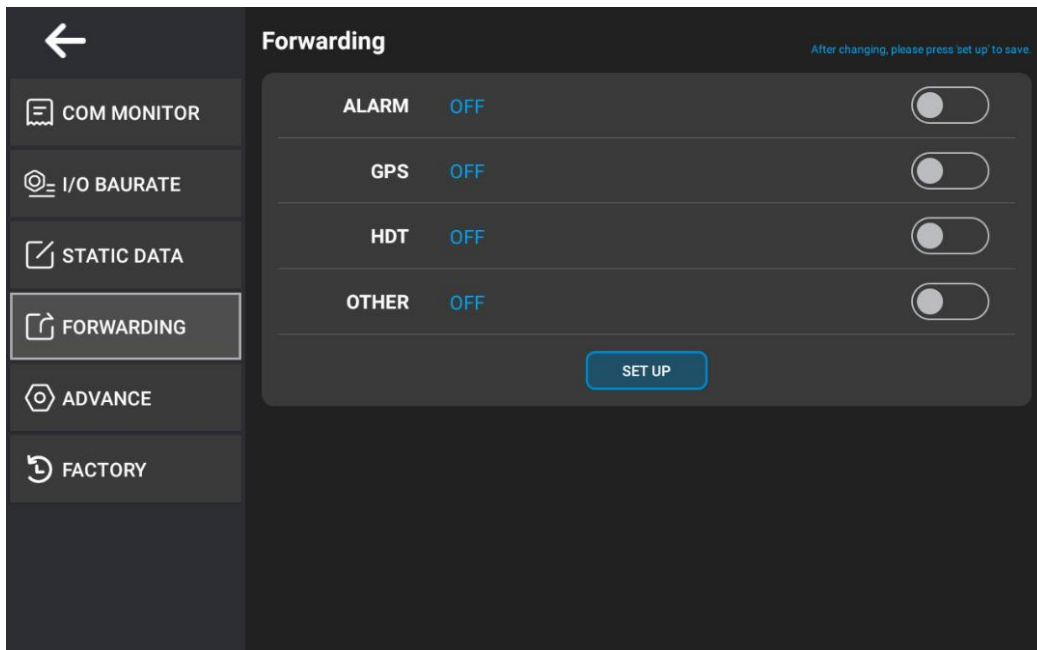

6.5 ADVANCED SETTING (NSI-1000 MKD)

[Advanced Setting] has three items:

- **AIS MODE:** Click  to set to **SOLAS** mode from **INLAND** mode.
- **TX VER:** It's to check the firmware version of the AIS transponder.

- **GNSS:** Select GNSS mode among GPS&BDS / GPS&GLO / GPS / BDS/ GLO / INTERNAL.

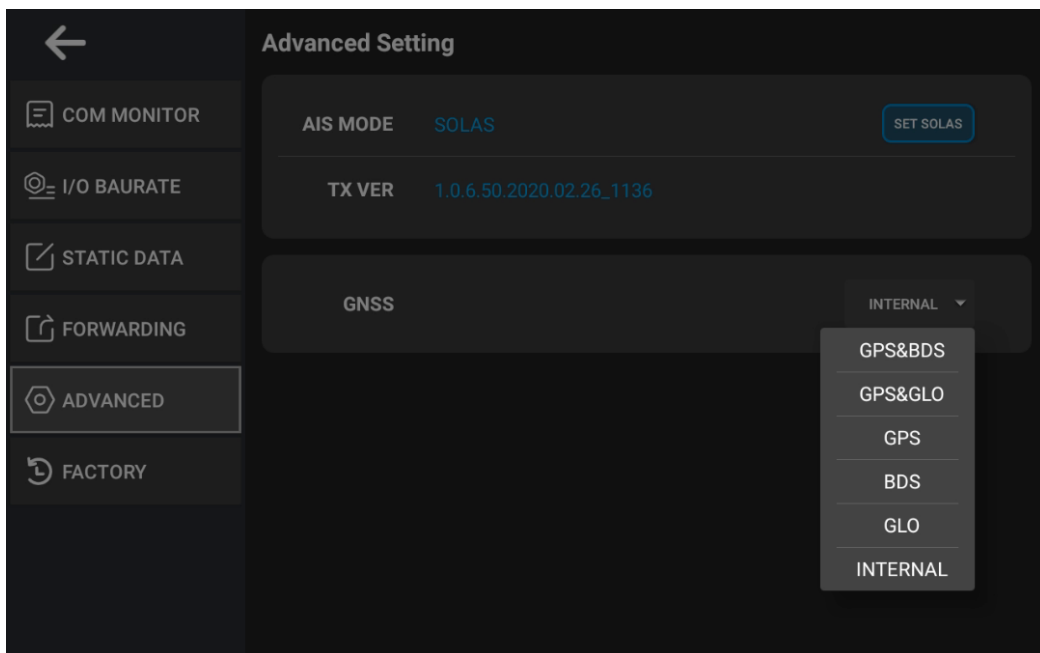
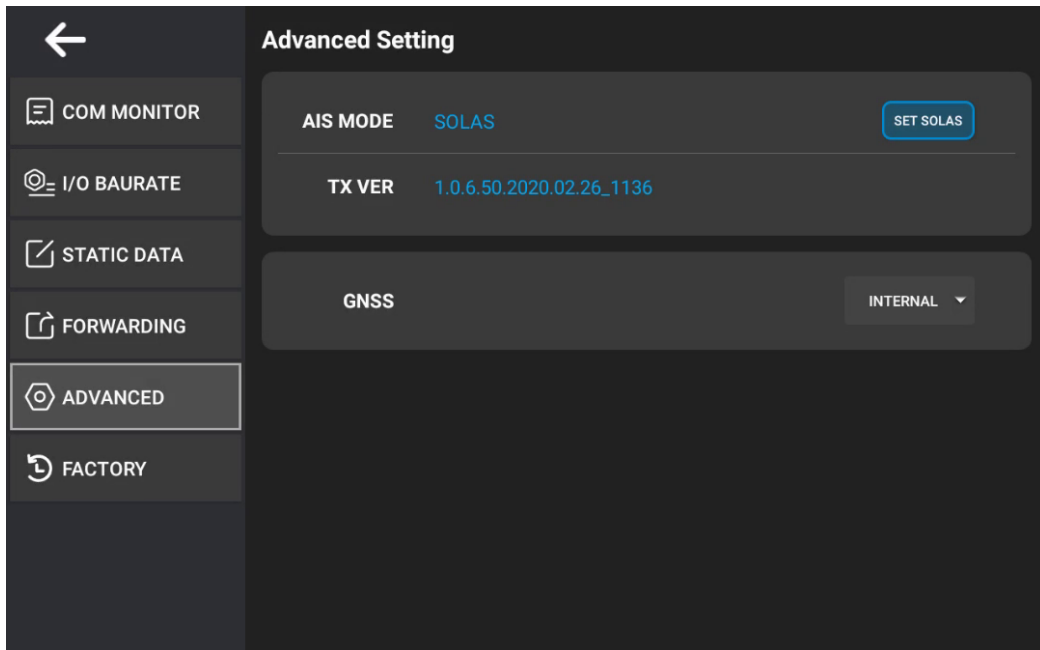

6.6 FACTORY SETTING

It's to restore the system setting as factory default settings.

NSI-1000 MKD:

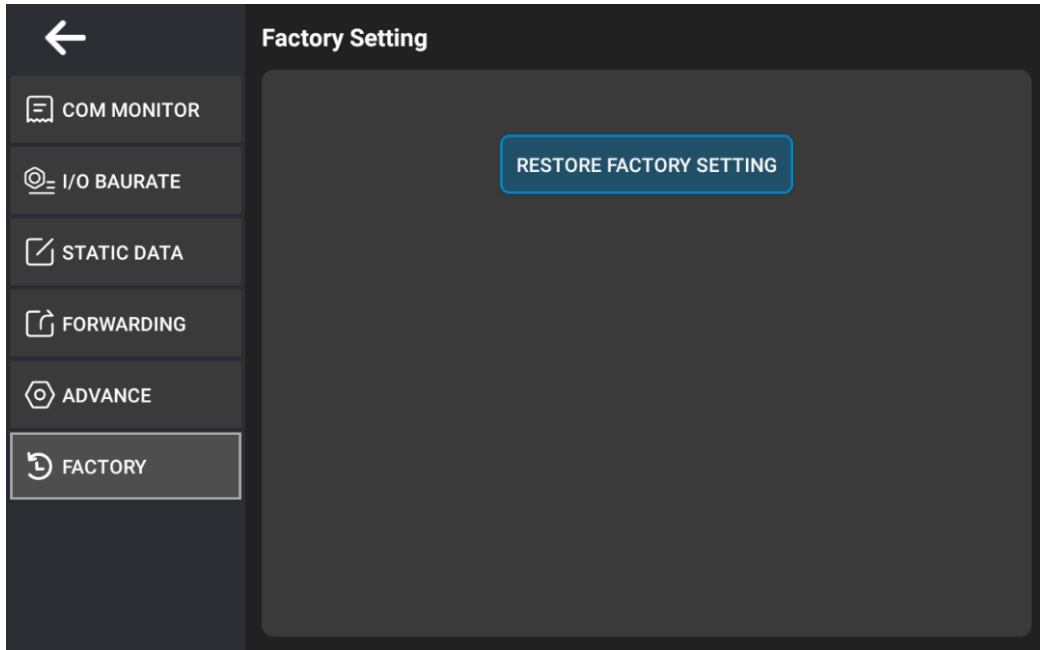

NAB-1000 MKD:

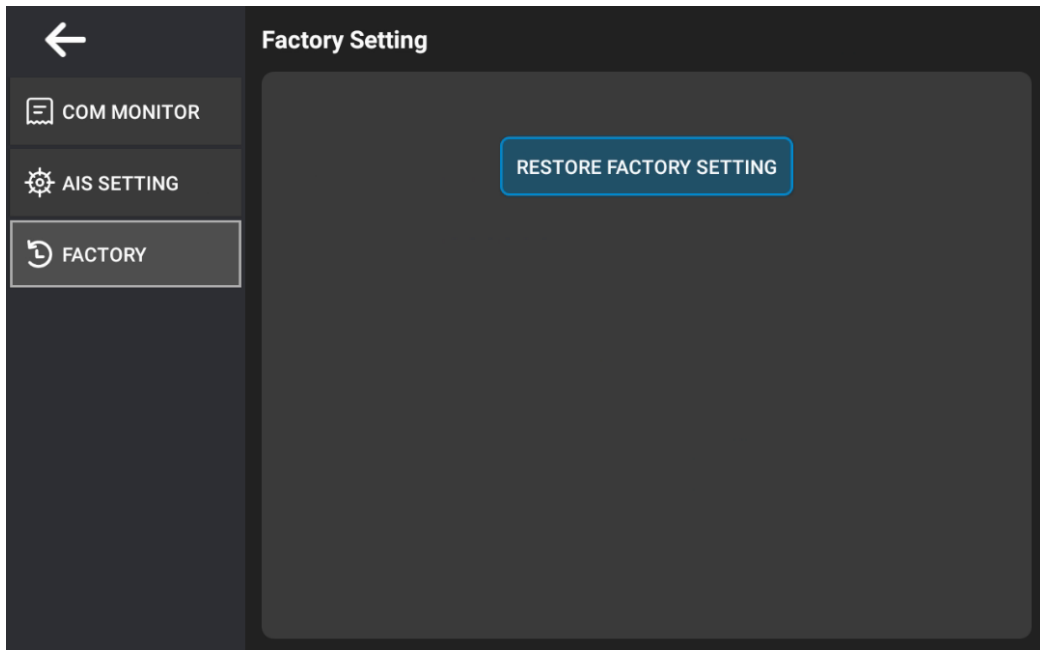

7. INSTALLATION

7.1 EQUIPMENT INSTALLATION

This Plotter can be installed as desktop, or wall mounting, or flush mounting in console. Flush mounting needs special brackets (to be separately ordered) .

NES-3010(G) installation refers to the Installation Drawings.

Please take following notes:

- Install in a place with good ventilation.
- Get enough space for cable connection.
- Less vibration.
- Keep away from electro-magnetic equipment, such as motor, generator.
- Keep away from ventilation pipe and exhaust duct.

7.2 GNSS ANTENNA INSTALLATION

If this Plotter installed alone, without connecting to ship borne AIS, GNSS antenna needs installing too.

Please refers to the Antenna Installation Drawing for GNSS antenna installation.

Please take the following notes when deciding the GNSS antenna location:

- Keep away from radar scanner and its radiation sector area。Radar radiation may damage or affect GNSS reception.
- No block to the satellite. The barriers, such as mast pole may block signal reception or extend the satellite searching time.
- Install a location as high as possible to avoid being blocked and prevent from splash of sea water.

7.3 CONNECTION

Please refer to drawings for connection.

8. MAINTENANCE

8.1 ROUTINE MAINTENANCE

In order to keep system functioning, routine maintenance is necessary. Check below once a month.

ITEM	DESCRIPTION
Connections	The port connection behind is secured with unused port covered.
Cable	Cables non damage. If damaged, replace.
Grounding Point	Check grounding point if rusty. Clean if necessary.
Grounding cable	Make sure it secured.
Screws	Check if loosen, secure if so.
Antenna and cable	Check GNSS antenna non damage, mounting/fixing is still secured. Waterproofing tape/glue in connection point is still fine. If not, make it good.
Main Unit	Clean the dust with clean soft cloth. Do not use solvent or cleaning liquid, to avoid wipe off the print/mark or make enclosure reshaped.



8.2 TROUBLESHOOTING

Below are common problems and possible solutions. If the problem cannot be recovered, please contact your local dealer or manufacturer.

Problem	Solutions
Power	
Cannot Power On	<ul style="list-style-type: none"> ● Check the power cable is connected securely. ● Check if power source onboard stable when NES-3010G installed alone. ● Check if AIS transponder works normal when NES-3010 working with AIS equipment.
GNSS POSITION	
GNSS Position lost	<p>If NES-3010 installed as MKD:</p> <ul style="list-style-type: none"> ● Check AIS equipment if GNSS position is fixed. ● If GNSS possible is valid at AIS transponder, but invalid at MKD, check connection cable between. <p>If NES-3010G installed alone:</p> <ul style="list-style-type: none"> ● Check if GNSS antenna is damaged. ● Check if GNSS antenna cable and connectors are well connected. ● Replace with a new antenna if necessary. ● If GNSS antenna is ok, and position is still not fixed, contact your local dealer.
AIS INFORMATION	
No AIS Target	<ul style="list-style-type: none"> ● Check whether AIS equipment is receiving normally. ● Check the right AIS type is selected in AIS Class of System Setting.

8.3 COMMUNICATION WITH AIS TRANSPONDER

The result of communication with the AIS transponder is described as follows:

Result	Display	Solution/Remarks
Set up successfully!	 Set up successfully	OK.
Set up failed!	 Set up failed!	<ul style="list-style-type: none"> ● Try to set again. ● Check if NEMA sentence is detected in [ADVANCE] – [COM MONITOR]. ● Check the connection of the AIS transponder. ● Check whether the serial port is available. ● Check whether the serial port baud rates are the same. <p>Note: NSI-1000 (115200bps), NAB-1000 (38400bps)</p>

APPENDIX 1 TECHNICAL SPECIFICATIONS

- **General**

CPU:	Quad-Core 64 bit ARM
Main Frequency:	1.5 GHz
RAM:	2 GB
ROM:	8 GB
OS:	Android

- **GNSS RECEIVER**

Receiving System:	72 channels parallel
RX Frequency:	GPS L1, GLONASS L1, BDS B1
RX Code:	C/A code
Position-fixing Time:	Warm start: 45 seconds Cold start: 60 seconds
Auto Positioning:	2 minutes
Refreshing:	Once per second
Positioning Accuracy:	≤10m (95%) (When connected to AIS and receive RTCM signal broadcasted by AIS Base Station, DGPS available, with accuracy of position up to 2m)

- **Power Source**

Voltage:	DC 24V (9 V ~ 36 V)
Current:	≤0.8A
Consumption:	<10W

- **LCD Display**

Feature:	Touch screen operation
Size:	10.1"
Resolution:	1280×800

- **Size**

Size:	189.8 (H) × 321.3 (W) × 100.6 (D) mm (Plotter)
-------	--

- **Weight**

Weight:	4kg (Plotter)
---------	---------------

- **Interface**

Interface:	RS232×1, USB×1 (NES-3010) RS422×2, USB×1 (NES-3010G)
------------	---

- **Environmental Conditions**

Temperature:	-15°C ~ +55°C
Humidity:	≤93%RH (40°C)
Vibration:	Max 1G (50Hz), compliance to IEC60945
IP Grade:	IP22 (Plotter), IP66 (Antenna)

APPENDIX 2 MENU TREE

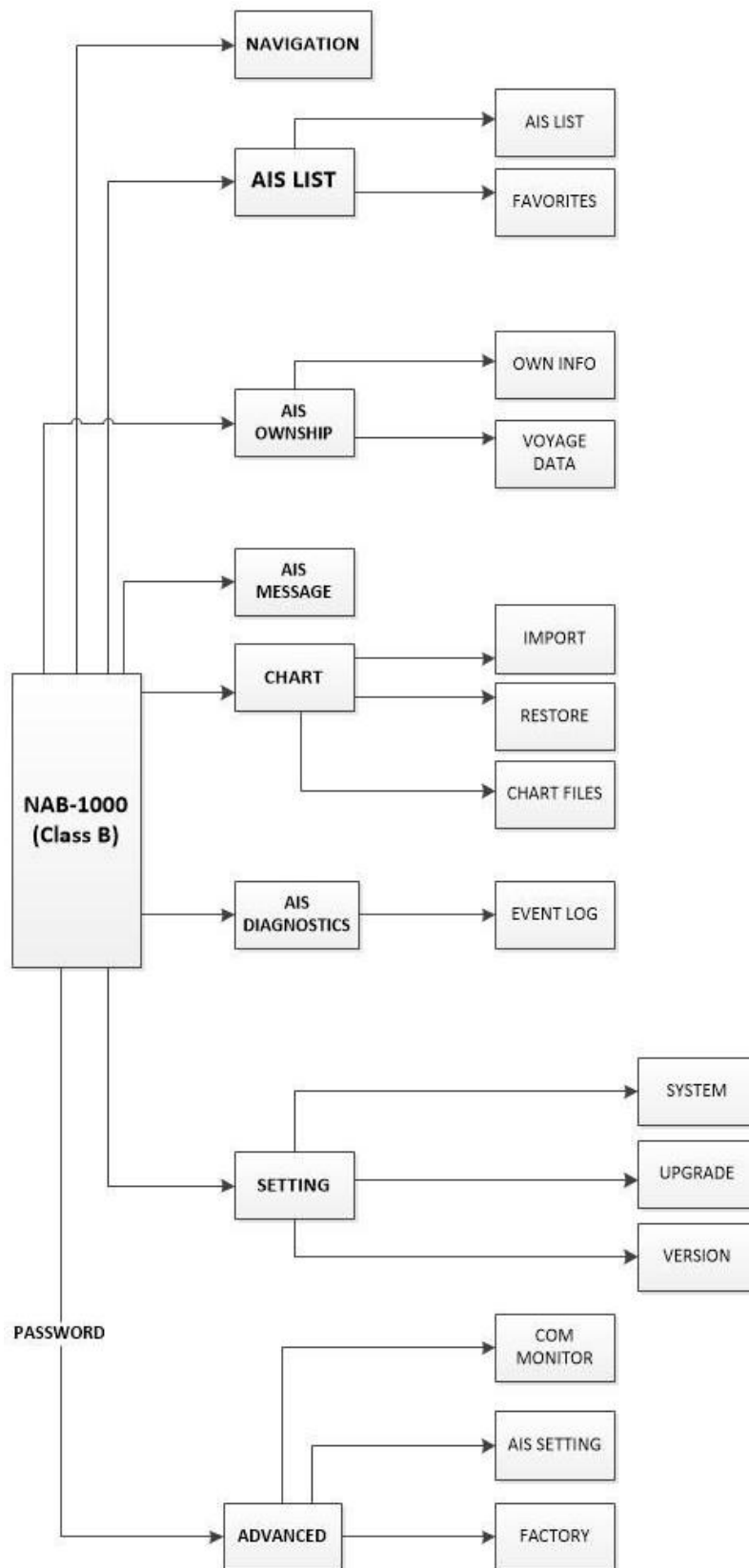

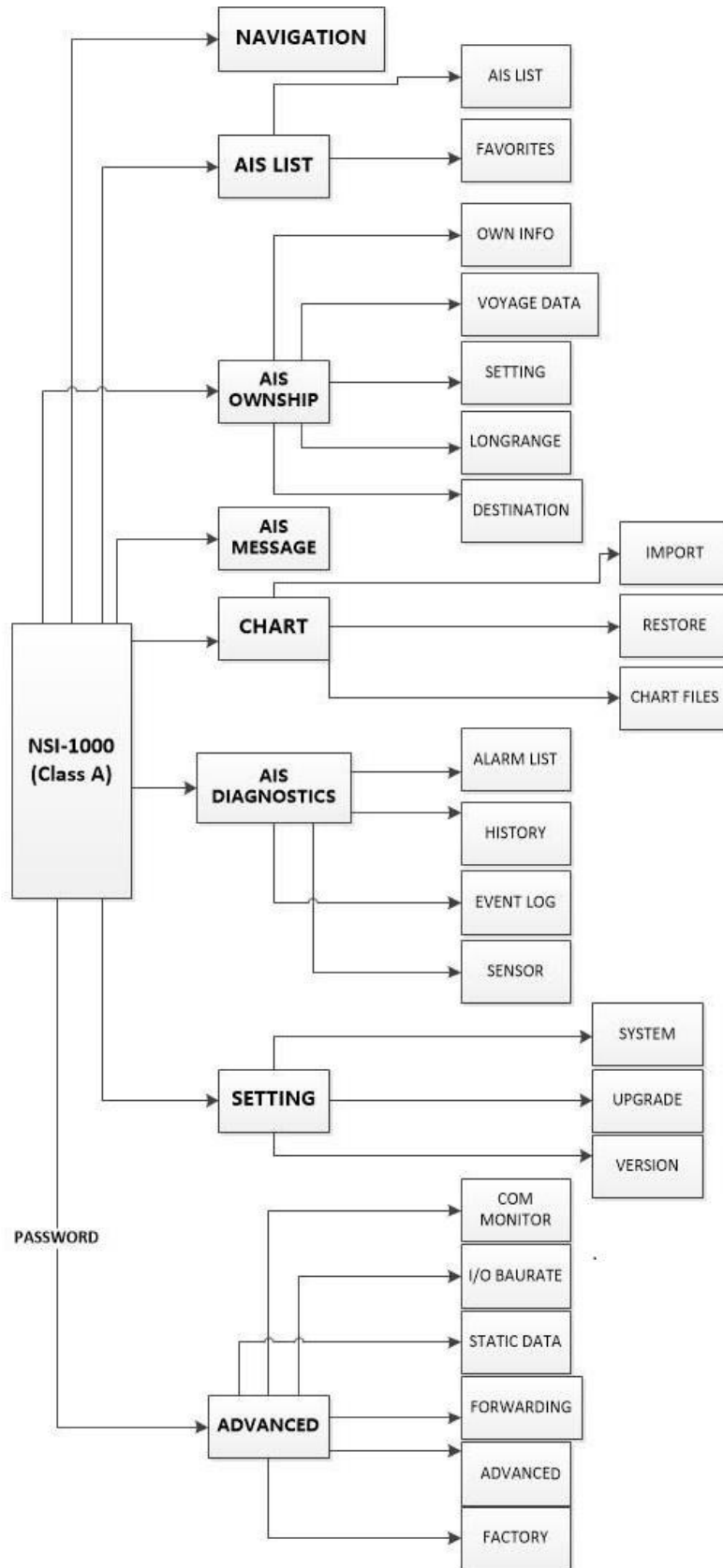

APPENDIX 3 LIST OF SHIP TYPE

0	UNDEFINED
20	WIG: ALL SHIPS OF THIS TYPE
30	FISHING VESSEL
31	TOWING VESSEL
32	LENGTH OF THE TOW EXCEEDS 200M OR BREADTH EXCEEDS 25M
33	VESSEL ENGAGED IN DREDGING OR UNDERWATER OPERATIONS
34	VESSEL ENGAGED IN DIVING OPERATIONS
35	VESSEL ENGAGED IN MILITARY OPERATIONS
36	VESSEL SAILING
37	PLEASURE CRAFT
40	HSC
50	PILOT VESSEL
51	SEARCH AND RESCUE VESSELS
52	TUGS
53	PORT TENDERS
54	VESSELS WITH ANTI-POLLUTION FACILITIES OR EQUIPMENT
55	LAW ENFORCEMENT VESSELS
58	MEDICAL TRANSPORTS
59	SHIPS ACCORDING TO RESOLUTION NO 18 (MOB-83)
60	PASSENGER SHIP
70	CARGO SHIP
80	TANKER SHIP
90	OTHER TYPE OF SHIP

Note: WIG: Wing-in-Ground Craft

APPENDIX 4 ABBREVIATIONS

ACK	Acknowledge
ADD	Addressed
AIS	Automatic Identification System
ALM	Alarm
ANT	Antenna
ATON	Aid to Navigation
AUTO	Automatic
AUX	Auxiliary
BRD	Broadcast
BRG	Bearing
CH	Channel
CLR	Clear
COG	Course over Ground
CPA	Closest Point of Approach
DEL	Delete
DG	Dangerous Goods
DGNSS	Differential Global Navigation Satellite System
DGPS	Differential Global Positioning System
DIFF	Differential
DSC	Digit Selective Calling
DTE	Data Terminal Equipment
ECS	Electronic Chart System
ECDIS	Electronic Chart Display & Information System
EGNOS	European Geo-stationary Navigational Overlay System
EMC	Electro Magnetic Compatibility
ENG	English
ENT	Enter
ESC	Escape
ETA	Estimated Time of Arrival
EXT	External
FM	Frequency Modulation
FSK	Frequency Shift Keying
GAGAN	GPS-aided geo-augmented navigation
GND	Ground
GLONASS	Global Orbiting Navigation and Safety System
GMSK	Gaussian Minimum Shift Keying
GNSS	Global Navigation Satellite System
GPS	Global Positioning System
GYRO	Gyro Compass
HDG	Heading
HS	Harmful Substances
IALA	International Association of Lighthouse Authorities
IEC	International Electrotechnical Commission
IMO	International Maritime Organization
INMARSAT	International Maritime Satellite Organization

INT	Internal
I/O	Input/Output
ITU	International Telecom Union
KN	Knots
LAN	Latitude
LCD	Liquid Crystal Display
LON	Longitude
L/R	Long Range
LRM	Long-range Message
LT	Local Time
MIN	Minute
MKD	Minimum Keyboard and Display
MMSI	Maritime Mobile Service Identity
MOB	Man Overboard
MSAS	Multi-functional Satellite Augmentation System
MSC	Maritime Safety Committee
MSG	Message
NAV	Navigation
NUM	Number
NM	Nautical Mile
NMEA	National Marine Electronics Association
PI	Presentation Interface
POS	Position
PWR	Power
RNG	Range
ROT	Rate of Turn
RTCM	Radio Technical Commission for Maritime services
RX	Receiving (Receiver)
RXD	Received/Receiving Data
S	Second
SAR	Search and Rescue
SART	Search and Rescue Transponder
SBAS	Satellite Based Augmentation System
SOG	Speed over Ground
SOLAS	International Convention for Life and Safety at Sea
TCPA	Time to Closest Point of Approach
TDMA	Time Division Multiple Access
TX	Transmitting (Transmitter)
TXD	Transmitted/Transmitting Data
UTC	Coordinated Universal Time
VHF	Very High Frequency
WAAS	Wide Area Augmentation System

APPENDIX 5 INSTALLATION DRAWINGS

NO.	DATE	REVISION & DESCRIPTION	REVIEWED	CHECKED
△			SIGNATURE	

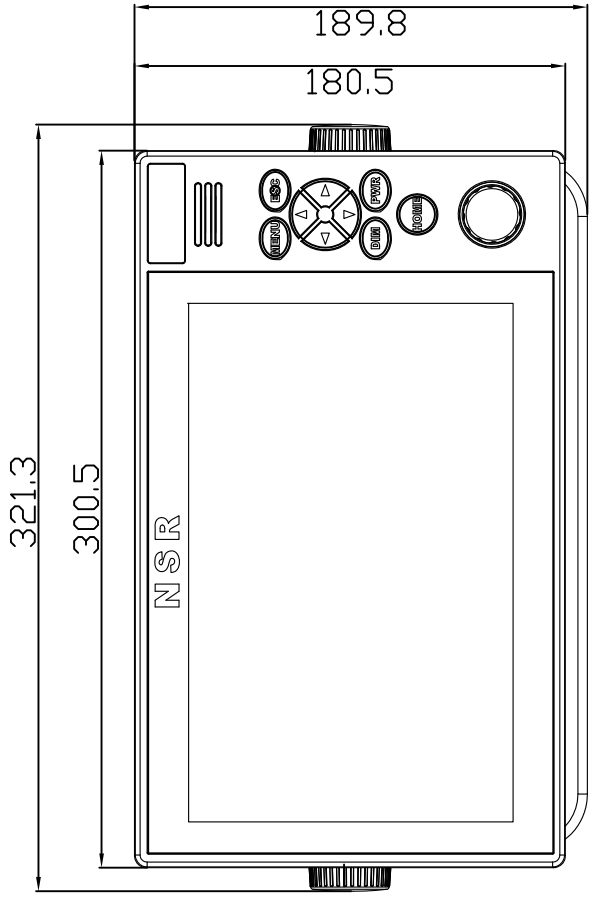

FRONT VIEW

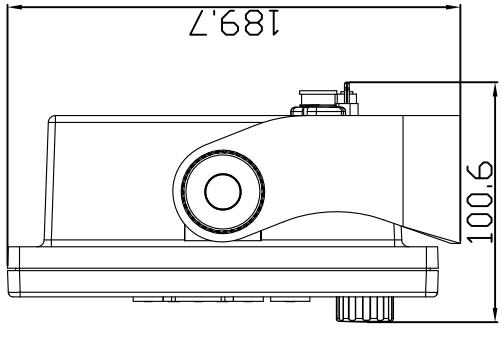

SIDE VIEW

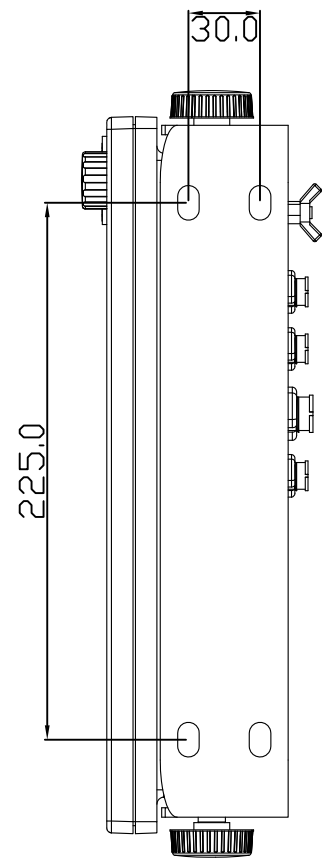

BOTTOM VIEW

APPLICATION										NES-3010(G) PLOTTER SIZE DRAWING										
DATE	ITEM	SCALE	UNIT	UNIT	UNIT	UNIT	UNIT	UNIT	UNIT	UNIT	UNIT	UNIT	UNIT	UNIT	UNIT	UNIT	UNIT	UNIT	UNIT	UNIT
APPROVAL	SCALE	UNIT	UNIT	UNIT	UNIT	UNIT	UNIT	UNIT	UNIT	UNIT	UNIT	UNIT	UNIT	UNIT	UNIT	UNIT	UNIT	UNIT	UNIT	UNIT
CHECKED	SCALE	UNIT	UNIT	UNIT	UNIT	UNIT	UNIT	UNIT	UNIT	UNIT	UNIT	UNIT	UNIT	UNIT	UNIT	UNIT	UNIT	UNIT	UNIT	UNIT
DRAWING	SCALE	UNIT	UNIT	UNIT	UNIT	UNIT	UNIT	UNIT	UNIT	UNIT	UNIT	UNIT	UNIT	UNIT	UNIT	UNIT	UNIT	UNIT	UNIT	UNIT
DATE	SCALE	UNIT	UNIT	UNIT	UNIT	UNIT	UNIT	UNIT	UNIT	UNIT	UNIT	UNIT	UNIT	UNIT	UNIT	UNIT	UNIT	UNIT	UNIT	UNIT
DATE	SCALE	UNIT	UNIT	UNIT	UNIT	UNIT	UNIT	UNIT	UNIT	UNIT	UNIT	UNIT	UNIT	UNIT	UNIT	UNIT	UNIT	UNIT	UNIT	UNIT



NES3010(G)-HD-001

NO.	DATE	REVISION & DESCRIPTION	REVIEWED	CHECKED
△			SIGNATURE	

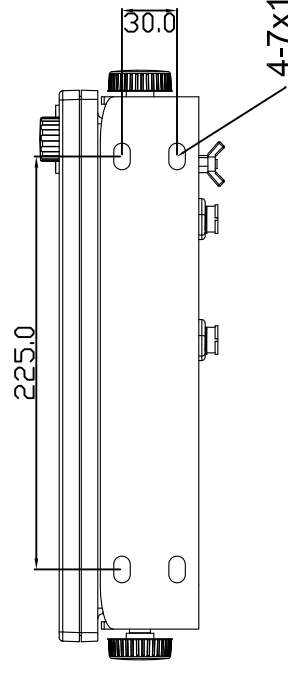
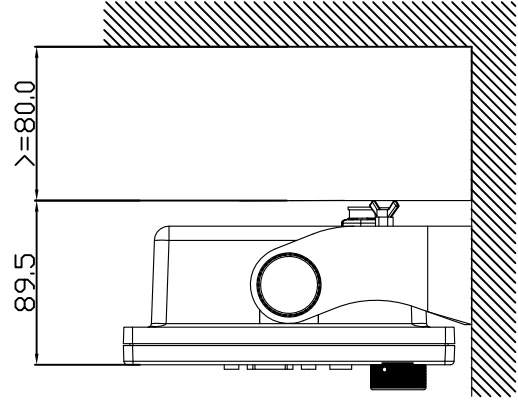
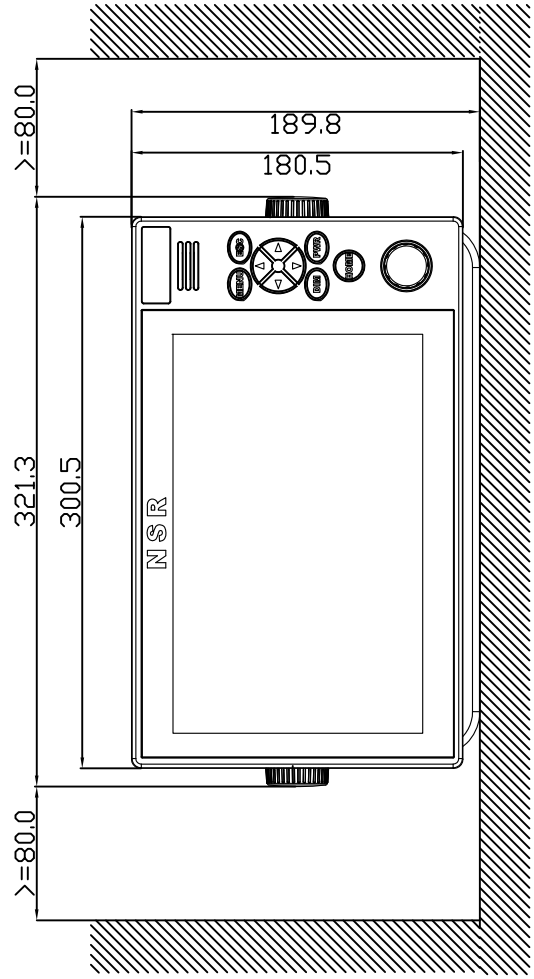

4-7x11 SLOT, FITTING HOLE

NOTE: TABLE TYPE

1. USE SELF-TAPPING SCREWS M5X20 FOR FIXING THE UNIT.
2. 80MM IS MINIMUM SPACE FOR OPERATION AND CABLING.

APPLICATION NES-3010(G) PLOTTER MOUNTING DRAWING(TABLE TYPE)									
DATE	ITEM	SCALE	UNIT	UNIT	UNIT	UNIT	UNIT	UNIT	UNIT
APPROVAL	SCALE	UNIT	UNIT	UNIT	UNIT	UNIT	UNIT	UNIT	UNIT
CHECKED	SCALE	UNIT	UNIT	UNIT	UNIT	UNIT	UNIT	UNIT	UNIT
DRAWING	SCALE	UNIT	UNIT	UNIT	UNIT	UNIT	UNIT	UNIT	UNIT
DATE	SCALE	UNIT	UNIT	UNIT	UNIT	UNIT	UNIT	UNIT	UNIT
NES-3010(G)HD-002									

A | B | C | D | E | F | F | F | G | H | I
 1 | 2 | 3 | 4 | 5 | 6

NO.	DATE	REVISION & DESCRIPTION	REVIEWED	CHECKED
△			SIGNATURE	

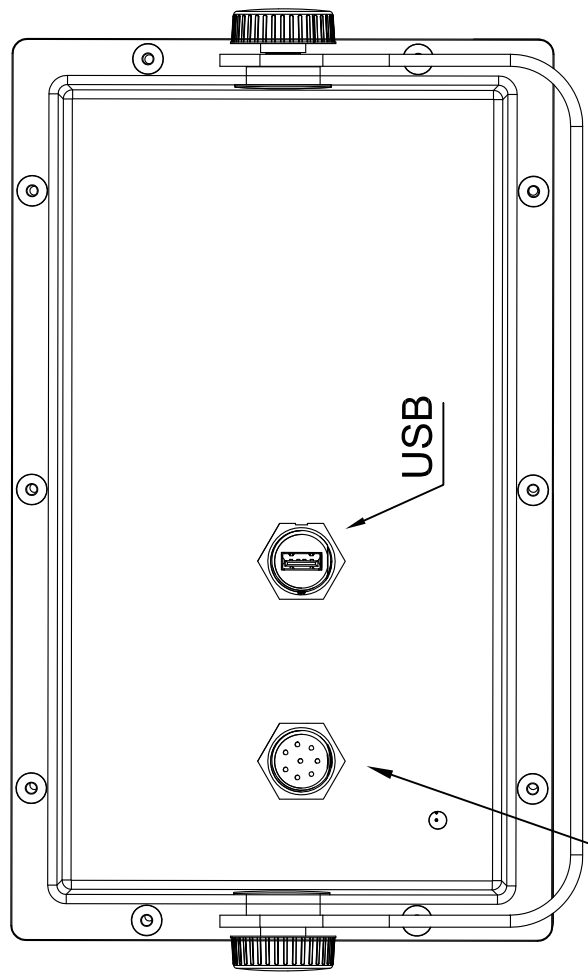

- 1. DC24V
- 2. NC
- 3. TXD
- 4. RXD
- 5. GND
- 6. DC0V
- 7. NC
- 8. NC

APPLICATION NES-3010 PORT DESCRIPTION DIAGRAM									
DATE	ITEM	SCALE	NO.	UNIT	REV.	DATE	DATE	DATE	DATE
APPROVAL	SCALE	NO.	UNIT	REV.	DATE	DATE	DATE	DATE	DATE
CHECKED									
DRAWING									
INCH									
NES3010(G)HD-004									

A | B | C | D | E | F | F | F | G | H | I
 1 | 2 | 3 | 4 | 5 | 6

NO.	DATE	REVISION & DESCRIPTION	CHECKED
△			SIGNATURE

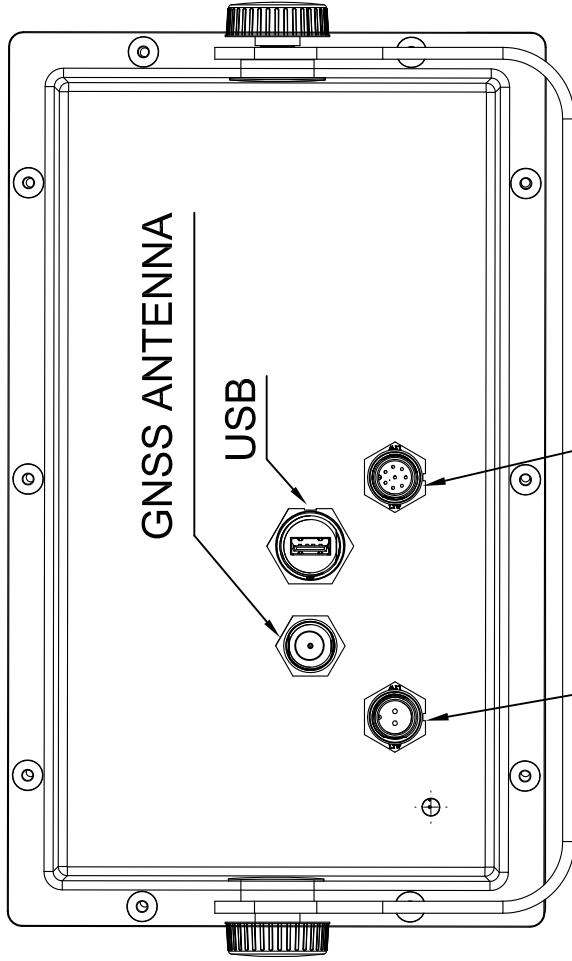

- | | |
|---------------------------------|---|
| POWER
1. 24V
2. 0V | P1
1. DATA 1_RXB
2. DATA 1_RXA
3. DATA 1_TXA
4. DATA 1_TXB
5. DATA 2_RXB
6. DATA 2_RXA
7. DATA 2_TXA
8. DATA 2_TXB |
|---------------------------------|---|

APPLICATION NES-3010(G) PORT DESCRIPTION DIAGRAM									
DATE	ITEM	SCALE	NO.	UNIT	REV.	DATE	DATE	DATE	DATE
APPROVAL	SCALE	NO.	UNIT	REV.	DATE	DATE	DATE	DATE	DATE
CHECKED									
DRAWING									
ING. NO.	NES3010(G)-HD-005								

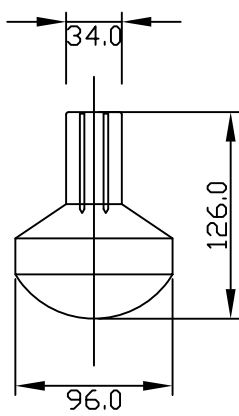

NGA100 GNSS ANTENNA

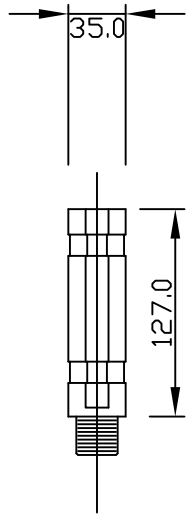

MOUNT POLE

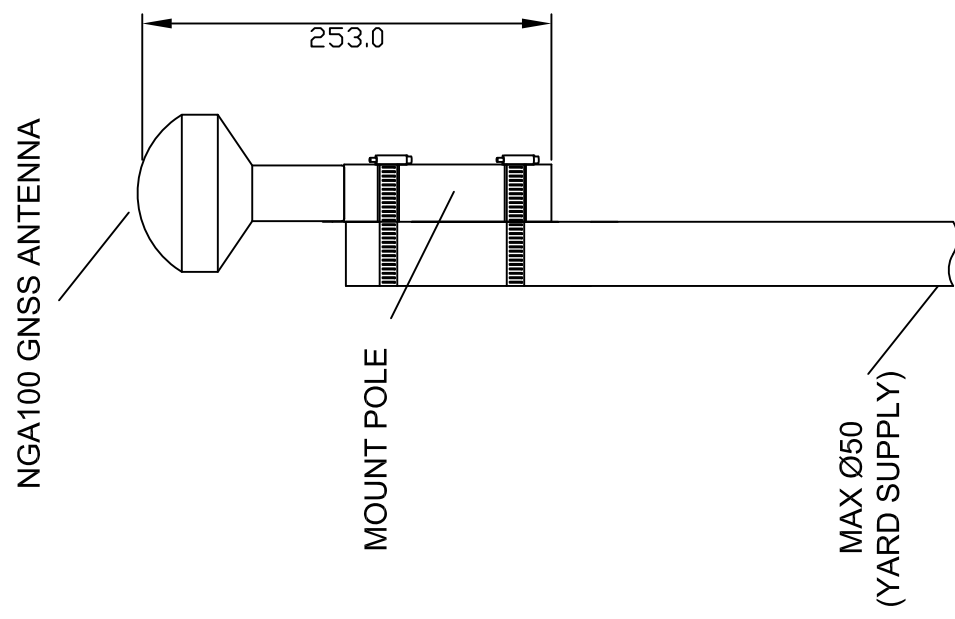

NGA100 GNSS ANTENNA

MOUNT POLE

MAX Ø50
(YARD SUPPLY)

APPLICATION				GNSS ANTENNA MOUNTING DRAWING			
DATE	ITEM	SCALE	IN/S	UNIT	mm	SIZE	A4
APPROVAL							
CHECKED							
DRAWING							
DWG NO.	NES3010(G)-ID-006			 NEW SUNRISE CO., LTD.			

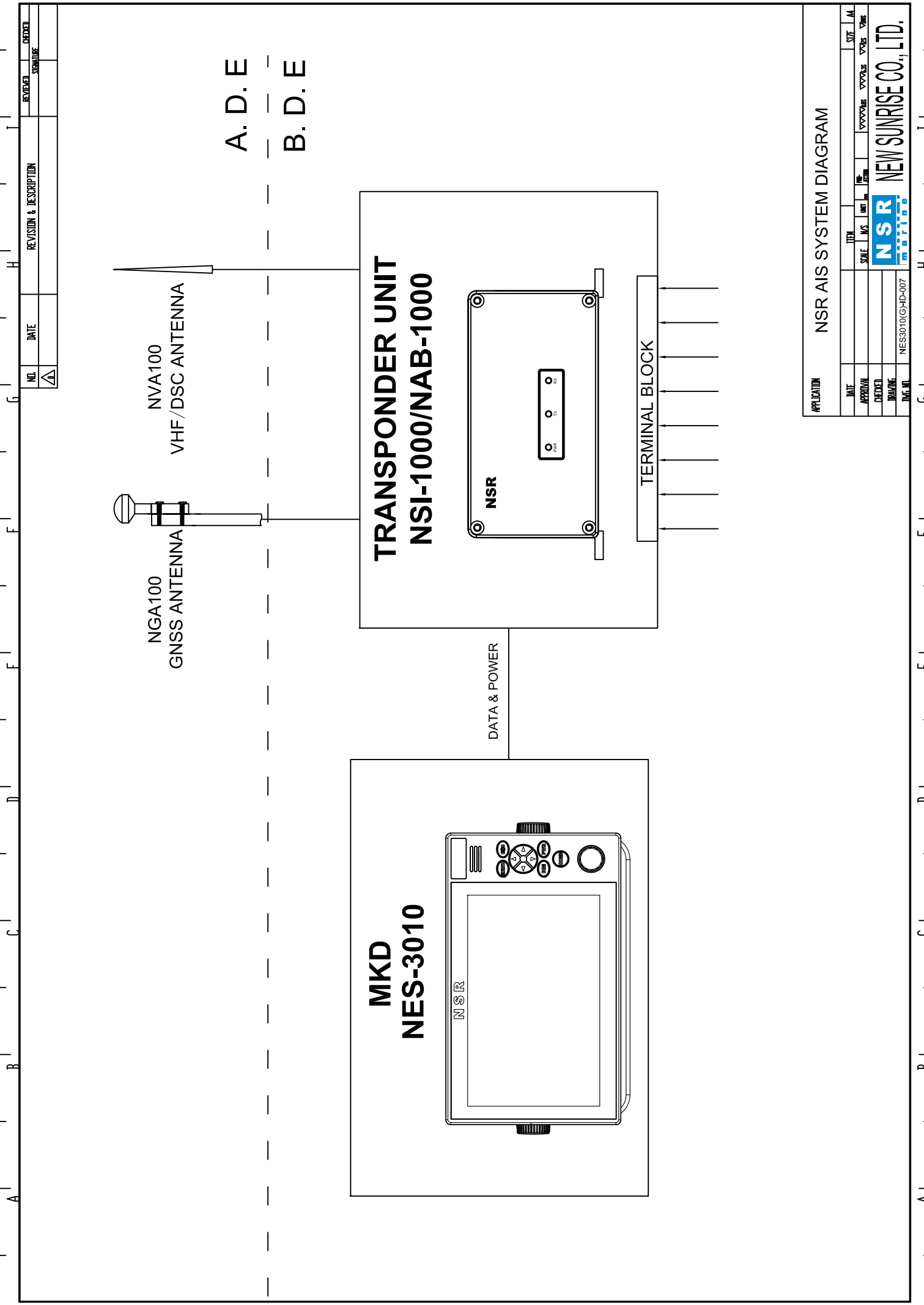

NO.	DATE	REVISION & DESCRIPTION	REVIEWED	DRAWN
1				

NGA100
GNSS ANTENNA

NVA100
VHF/DSC ANTENNA

A. D. E

B. D. E

TRANSPONDER UNIT
NSI-1000/NAB-1000

NSR

TERMINAL BLOCK

MKD
NES-3010

NSR

DATA & POWER

APPLICATION: NSR AIS SYSTEM DIAGRAM									
DATE	ITEM	SCALE	NO.	REV.	DATE	BY	CHKD.	DATE	BY
APPROVAL	CHECKED	DESIGNED							
NEW SUNRISE CO., LTD.									
NES3010(G)-HD-007									