

# TWO-WAY VHF RADIO

NTW-3000

NSR's new generation of two-way VHF radio:

- Watertight design
- Either primary battery or secondary battery is available
- 4-digital channels available
- External MIC/Speaker can be attached



- Designed to meet GMDSS requirements related with performance standards for survival craft two-way VHF radio telephone apparatus, such as IMO MSC.149 (77), MSC.515(105), MSC.1/Circ.1460/Rev.4 and IEC 61097-12.
- Compact, lightweight and rugged construction.
- Full marine-use VHF channels can be available.



## SPECIFICATIONS

### ● TECHNICAL SPECIFICATIONS

- Frequency Range: 156.000~161.450 MHz (TX)  
156.000~163.425 MHz (RX)
- Operating Channels: 19 channels (default)
- Operating Hours:  $\geq$ 8 hours (TX10%, RX10%, Standby80%)
- Output Power: High 3.0 W / Low 1.0 W

### ● BATTERY REQUIREMENTS

- Battery Voltage: DC9V (NBT800), DC7.4V (NBT800C)
- Storage Temp: -30°C~+70°C
- Storage Life for NBT800: Max 4 years on board  
(plus one year of shelf time)

### ● SIZE & WEIGHT

- Size: 277.5 (H)×60.8 (W)×44.7 (D) mm
- Weight: about 300g (Transceiver + Emergency Battery)

### ● IP GRADE

- IP67 (Transceiver / Antenna / Battery)
- IP22 (Charger / Adaptor)

## SIZE DIMENSION

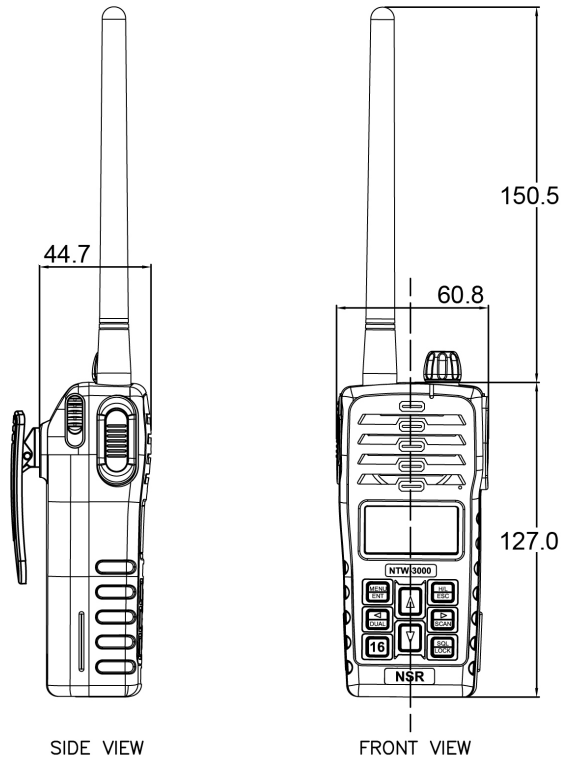

## EQUIPMENT LIST

### ● STANDARD

- Transceiver & Antenna 1 set
- Emergency Battery (NBT800) 1 pc
- Belt Clip 1 pc
- Wrist Rope 1 pc
- Rechargeable Battery (NBT800C) 1 pc
- Battery Charger (NBT800CU) 1 pc
- AC/DC Adaptor (NBT800CUA) 1 pc



Battery  
Emergency / Rechargeable



Wrist Rope



Belt Clip



Battery Charger



AC/DC Adapter