



USER MANUAL



NAVTEX RECEIVER

NVX-1000/NVX-3000



NOTICE TO USERS

- Thanks for your purchasing this product NVX-1000/NVX-3000 NAVTEX RECEIVER.
- The copyright of this manual is owned by the manufacturer, NEW SUNRISE CO., LTD. (NSR). Prior written permission is required for copying or reproducing the manual or part of the manual.
- Please read this manual carefully to ensure proper use before installation and operation of the NVX-1000/NVX-3000.
- NSR is devoted to publish and maintain this user manual. As we continue to improve our products to satisfy customers' needs, information in this document is subject to change without prior notice. NSR does not make any representations or warranties (implied or otherwise) regarding the accuracy and completeness of this document and shall in no event be liable for any loss of profit or any commercial damage, including but not limited to special, incidental, consequential, or other damage.
-
- NSR will assume no responsibility for the damage caused by improper use or modification of the product or claims of loss of profit by a third party.
- Software version in your product may be some different from that described as in this manual. Such difference will not affect the performance of the product. NSR reserves the right on continuous improvement of products both in software and hardware without any prior notice.
- Please keep the manual for your future reference.

SAFETY INSTRUCTIONS FOR THE OPERATOR

	Warning Keep away from heater source or direct sunshine.
	Prohibition Don't open the equipment. Only qualified personnel should work inside the equipment. Don't disassemble or try to modify the equipment.
	Dangerous Turn off the power immediately when smoke or fire is emitted.

SAFETY INSTRUCTIONS FOR THE INSTALLER

	Warning Connect the earth cord to ship's body. Observe the compass safe distance to prevent deviation of an onboard magnetic compass.
	Prohibition Don't open the equipment unless you have fully understood the structure and circuits of the equipment. Only qualified personnel should work inside the equipment. Don't disassemble or try to modify the equipment.
	Dangerous Turn off the power at power distribution board before installation.

Note: Information relating to the disposal of the unit at the end of its operational life:
Do not throw away the appliance with the normal household waste at the end of its operational life, but hand it in at an official collection point for recycling. By doing this, you help to preserve the environment.

MODIFY RECORD

No.	Modify by	Date	Paragraph	Version	Reason
1	Q/A	2010/03/07		01	First edition
2	Q/A	2014/09/30	1.4	02	NAVTEX station list
3	Q/A	2018/06/12	2.1	03	Standards
4	Q/A	2019/05/06	all	04	Product update
5	Q/A	2019/05/10	2.1	05	Meet IMO New Rule
6	Q/A	2021/06/03	all	06	General modification
7	Q/A	2021/08/05	2.3, 3.2, 4.1, 4.3, 5, App.1	07	Add BAM interface description etc.
8	Q/A	2022/09/16	2.3, 5.6, App.2	08	Some modification
9	Q/A	2024/05/16	all	09	General modification
10	Q/A	2025/12/31	2, 2.3, 4.3.5.1, App.4	10	Some modification

VERSION COMPARISON TABLE

Manual Version	Program Version	Remarks
20240516_09	App: 1.11, 20240315	
20251231_10	App: 1.14, 20240924	

CONTENTS

1. NAVTEX SYSTEM	1
1.1 NAVTEX INTRODUCTION.....	1
1.2 NAVTEX PRINCIPLE	2
1.3 NAVTEX MESSAGE FORMAT	4
1.4 NAVTEX STATION LIST	5
2. NVX-1000/NVX-3000 CONFIGURATION	8
2.1 NVX-1000/NVX-3000 OUTLINE	8
2.2 CONFIGURATION OF NVX-1000/NVX-3000	8
2.3 SUPPLY SCOPE OF NVX-1000/NVX-3000.....	9
3. NVX-1000/NVX-3000 SPECIFICATIONS	10
3.1 SOFTWARE CHARACTERISTICS	10
3.1.1 B1 AND B2 CHARACTERS	10
3.1.2 B3 AND B4 CHARACTERS	10
3.1.3 PREAMBLE.....	10
3.1.4 REPETITION OF DISPLAY	10
3.1.5 MANDATORY DISPLAY.....	10
3.1.6 RECEPTION OF MESSAGES WITH CHARACTER ERRORS	10
3.2 HARDWARE SPECIFICATIONS	11
4. HOW TO OPERATE	12
4.1 BASIC OPERATION.....	12
4.1.1 OUTLINE OF MAIN UNIT	12
4.1.2 POWER ON / OFF	12
4.1.3 THE DEFAULT SCREEN AND CONTROL KEYS.....	13
4.1.4 MAIN MENU STRUCTURE	14
4.2 MESSAGE OPERATION.....	16
4.2.1 MESSAGE LIST.....	16
4.2.2 MESSAGE VIEW	16
4.2.3 MESSAGE TAG.....	17
4.2.4 MESSAGE PRINT	17
4.2.5 MESSAGE TO INS	17

4.3 MAIN MENU OPERATION	17
4.3.1 STATION SETTING.....	18
4.3.2 MESSAGE SETTING.....	19
4.3.3 ADVANCED FUNCTION	20
4.3.4 SYSTEM SETTING	22
4.3.5 DIAGNOSTICS.....	27
4.3.6 SERVICE	33
5. INSTALLATION.....	35
5.1 ANTENNA	35
5.2 MAIN UNIT.....	35
5.3 BAM/INS CONNECTION.....	36
5.4 EXTERNAL ALARM	36
5.5 POWER SUPPLY CONNECTION.....	36
5.6 PRINTER CONNECTION	36
5.7 DIGITAL INTERFACE	37
APPENDIX 1 ALERT SOLUTION	38
APPENDIX 2 SENTENCE DISCRPTION	39
APPENDIX 3 ABBREVIATIONS	44
APPENDIX 4 INSTALLATION DRAWINGS	45

1. NAVTEX SYSTEM

1.1 NAVTEX introduction

NAVTEX provides shipping with navigational and meteorological warnings and urgent information by automatic display and/or print out from a dedicated receiver.

NAVTEX is a component of the IMO/IHO World-Wide Navigational Warning Service (WWNWS) defined by IMO Assembly resolution A.706(17), as amended, and the WMO Manual on Marine Meteorological Services, Part *Ibis*, Provision of warnings and weather and sea bulletins (GMDSS application). It has been included as an element of the Global Maritime Distress and Safety System (GMDSS).

The original NAVTEX specification allowed for equipment with integral printers and precluded the fitting of equipment which relied on other ways of recording and displaying NAVTEX data.

The use of Liquid Crystal Displays and other Visual Display Units is now ubiquitous on ship's bridges and this revision of the specification allows for their use in displaying NAVTEX data.

IMO Resolution MSC.148 (77) states that the equipment should comprise radio receivers, a signal processor and:

either:

- a) an integrated printing device; or
- b) a dedicated display device, printer output port and a non-volatile message memory; or
- c) a connection to an integrated navigation system and a non-volatile message memory.

International NAVTEX services, refer to the frequency of 518kHz, and through international co-ordination to broadcast and automatically receive the maritime safety information in English language.

Domestic NAVTEX services, refer to the authority-specified frequencies 490kHz and 4209.5kHz, to broadcast and automatically receive the marine safety information in a national language.

1.2 NAVTEX principle

For navigation purposes, the world is divided into 16 areas as shown in the figure below. Each NAVTEX station has an identification code, from the A to Z. The frequency assigned to NAVTEX are 518 kHz , 490 kHz and 4209.5 kHz, and many stations exist in the same service coverage.

If the stations were to transmit without any rule, the system would collapse due to mutual interference. To avoid this problem, the following rules apply.

- The transmission schedule is determined so that two or more stations having a common service area may not overlap in time.
- Each station transmits with minimum required power to cover its service area (200 to 400 nautical miles nominal).

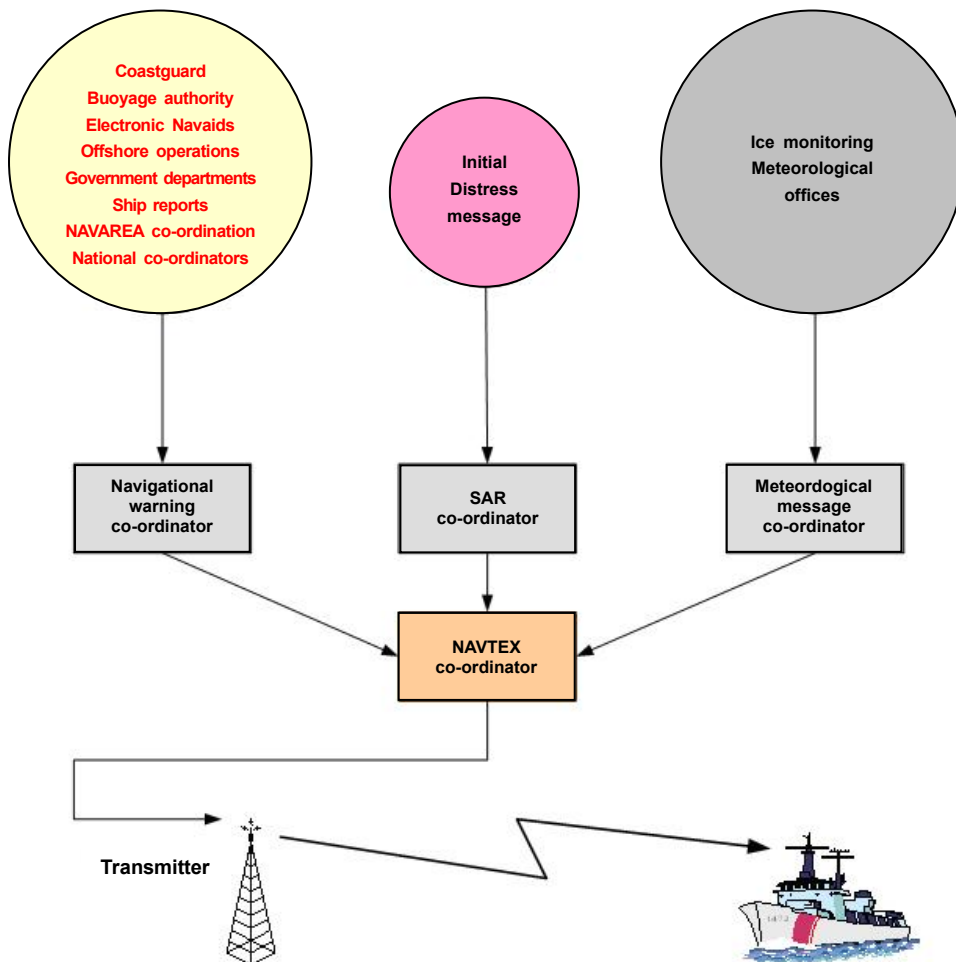

[Figure 1-1] Basic concept of the NAVTEX system

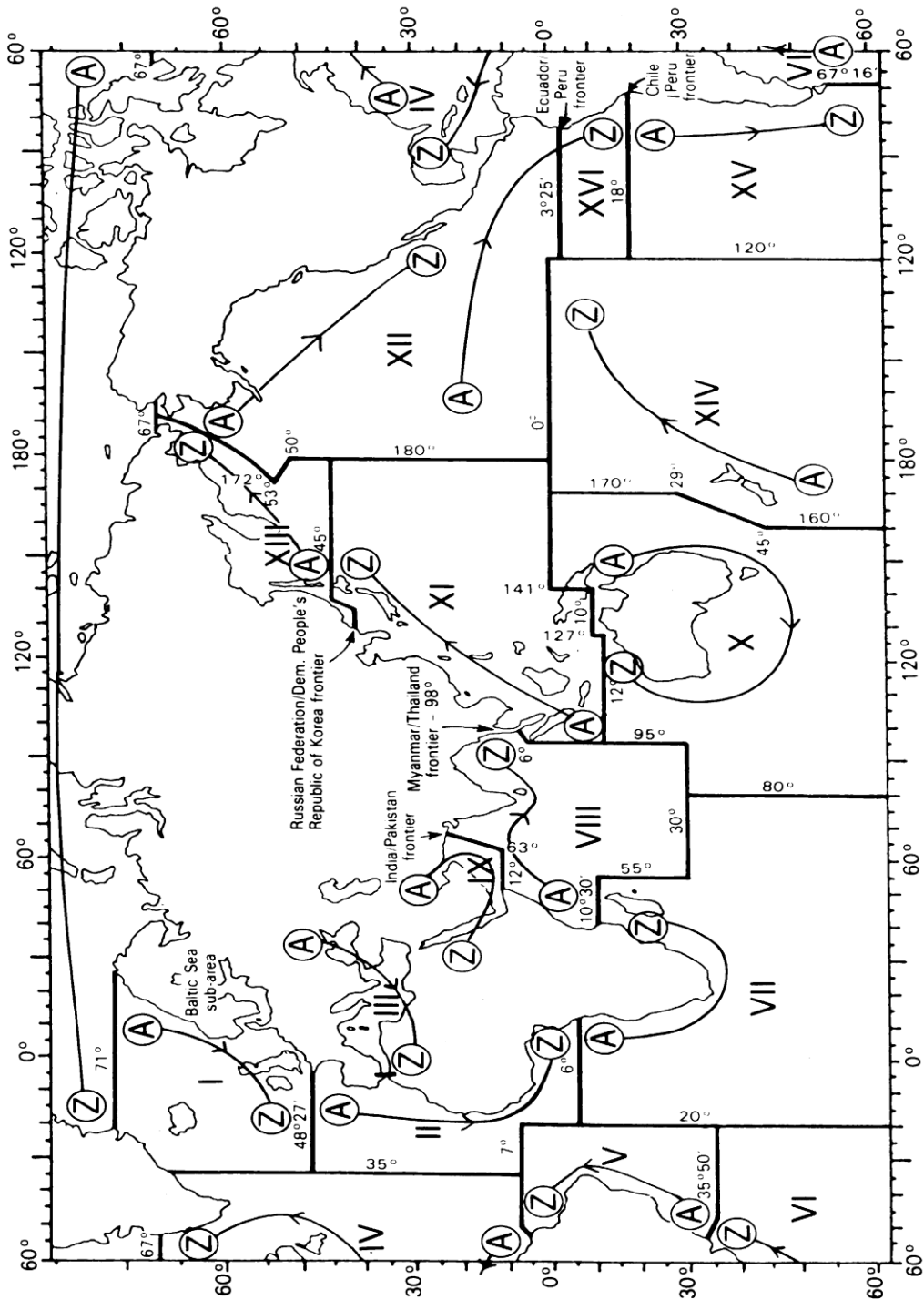

[Figure 1-2] NAVAREA of the WWNWS

1.3 NAVTEX message format

For automatic identification of NAVTEX messages, each message has its ID No which is identified as B1, B2, B3 and B4 to indicate origin, category and serial number of the message.

- Character B1 is the identification letter of the NAVTEX station “A” to “Z”.
- Character B2 indicates the type of message “A” to “Z”, as listed in [Table 1-1].
- Character B3 and B4 indicate the serial number of the message. The serial numbers are counted up from “01” to “99”, and starts from “01” again. “00” is specially reserved for important emergency messages.

The end of each message is indicated by “NNNN” (four successive N’s).
General message format is summarized below.

MESSAGE CONTENT

[VIEW MESSAGE]
518 490 4209

PAGE	ZJ0249 EAST CHINA SEA M/T JIU HUA SHAN PASS THE	<div style="text-align: center;">BACK</div> <div style="text-align: center;">PREV.</div> <div style="text-align: center;">NEXT</div> <div style="text-align: center;">PRINT</div> <div style="text-align: center;">TO INS</div>
ID	DREDGED DEEP-CHANNEL OUTSIDE XIAZHIMEN FAIRWAY VIA 29-41.26N/122-31.31E 29-41. 55N/122-30.21E 29-43.88N/122-21.39E 29- 44.28N/122-19.86E	
TIME-UTC	02-03 02:48	
SIZE	287	
CER	00% MSA CHINA	
STATE	NNNN	
CONTENT	NAVIGATIONAL WARNING	
[VIEW MESSAGE]		
[VIEW MESSAGE]		
[VIEW MESSAGE]		

ID No.

→

[Figure 1-3] NAVTEX Standard format for NAVTEX messages

Table 1-1 The message type table

Message Type (B2)	Content
A*	Navigational Warnings
B*	Meteorological Warnings
C	Ice Reports
D*	Search and Rescue information and pirate attack warnings
E	Meteorological Forecasts
F	Pilot service Messages
G	DECCA Messages
H	LORAN Messages
I	OMEGA Messages
J	SATNAV Messages
K	Other Electronic Navaid Messages
L*	Navigational Warnings -Additional letter “A”
M~Y	Reserved
Z	QRY

Remark: The character marked with “*”, can’t be rejected by the receiver.

1.4 NAVTEX station list

NAV Area	Country /Region	Station	Latitude	Longitude	Freq. (kHz)	Area (nm)	Station ID	Broadcast Schedule (UTC)
I	Belgium	Oostende	51°11'N	02°48'E	518	55	T	0310, 0710, 1110, 1510, 1910, 2310
	Estonia	Tallinn	59°30'N	24°30'E	518	250	U	0320, 0720, 1120, 1520, 1920, 2320
	Iceland	Reykjavik Radio	64°05'N	21°51'W	518	550	R	0250, 0650, 1050, 1450, 1850, 2250
					490	550	R	0318, 0718, 1118, 1518, 1918, 2318
	Ireland	Valentia	51°27'N	09°49'W	518	400	W	0340, 0740, 1140, 1540, 1940, 2340
		Malin Head	55°22'N	07°21'W	518	400	Q	0240, 0640, 1040, 1440, 1840, 2240
	France	Niton	50°35'N	01°18'W	518	270	K	0140, 0540, 0940, 1340, 1740, 2140
	Netherlands	Den Helder	52°06'N	04°15'E	518	110	P	0230, 0630, 1030, 1430, 1830, 2230
	Norway	Bodo Radio	67°16'N	14°23'E	518	450	B	0010, 0410, 0810, 1210, 1610, 2010
		Rogaland Radio	58°48'N	05°34'E	518	450	L	0150, 0550, 0950, 1350, 1750, 2150
		Vardoe Radio	70°22'N	31°06'E	518	450	V	0330, 0730, 1130, 1530, 1930, 2330
		Svalbard	78°04'N	13°38'E	518	450	A	0000, 0400, 0800, 1200, 1600, 2000
		Orlandet	63°40'N	09°33'E	518	450	N	0210, 0610, 1010, 1410, 1810, 2210
	Sweden	Bjuroklubb	64°28'N	21°36'E	518	300	H	0110, 0510, 0910, 1310, 1710, 2110
		Gislovshammar	55°29'N	14°19'E	518	300	J	0130, 0530, 0930, 1330, 1730, 2130
		Grimeton	57°06'N	12°23'E	518	300	D	0030, 0430, 0830, 1230, 1630, 2030
	United Kingdom	Cullercoats	55°02'N	01°26'W	518	270	G	0100, 0500, 0900, 1300, 1700, 2100
					490	270	U	0320, 0720, 1120, 1520, 1920, 2320
		Portpatrick	54°51'N	05°07'W	518	270	O	0220, 0620, 1020, 1420, 1820, 2220
					490	270	C	0020, 0420, 0820, 1220, 1620, 2020
		Niton	50°35'N	01°18'W	518	270	E	0040, 0440, 0840, 1240, 1640, 2040
					490	270	I	0120, 0520, 0920, 1320, 1720, 2120
	Oostende	51°11'N	02°48'E	518	150	M	0200, 0600, 1000, 1400, 1800, 2200	
	France	Cross Corsen	48°28'N	05°03'W	518	300	A	0000, 0400, 0800, 1200, 1600, 2000
					490	300	E	0040, 0440, 0840, 1240, 1640, 2040
		Niton	50°35'N	01°18'W	490	270	T	0310, 0710, 1110, 1510, 1910, 2310
	Portugal	Horta	38°32'N	28°38'W	518	640	F	0050, 0450, 0850, 1250, 1650, 2050
		Monsanto	38°44'N	09°11'W	518	530	R	0250, 0650, 1050, 1450, 1850, 2250
	490				530	G	0100, 0500, 0900, 1300, 1700, 2100	
	Spain	Coruna	43°21'N	08°27'W	518	400	D	0030, 0430, 0830, 1230, 1630, 2030
Tarifa		36°01'N	05°34'W	518	400	G	0100, 0500, 0900, 1300, 1700, 2100	
Las Palmas		28°10'N	15°25'W	518	400	I	0120, 0520, 0920, 1320, 1720, 2120	
II	France	Cross Corsen	48°28'N	05°03'W	518	300	A	0000, 0400, 0800, 1200, 1600, 2000
					490	300	E	0040, 0440, 0840, 1240, 1640, 2040
		Niton	50°35'N	01°18'W	490	270	T	0310, 0710, 1110, 1510, 1910, 2310
	Portugal	Horta	38°32'N	28°38'W	518	640	F	0050, 0450, 0850, 1250, 1650, 2050
		Monsanto	38°44'N	09°11'W	518	530	R	0250, 0650, 1050, 1450, 1850, 2250
	490				530	G	0100, 0500, 0900, 1300, 1700, 2100	
	Spain	Coruna	43°21'N	08°27'W	518	400	D	0030, 0430, 0830, 1230, 1630, 2030
		Tarifa	36°01'N	05°34'W	518	400	G	0100, 0500, 0900, 1300, 1700, 2100
Las Palmas		28°10'N	15°25'W	518	400	I	0120, 0520, 0920, 1320, 1720, 2120	
III	Bulgaria	Varna	43°04'N	27°46'E	518	350	J	0130, 0530, 0930, 1330, 1730, 2130
	Croatia	Split radio	43°30'N	16°29'E	518	85	Q	0240, 0640, 1040, 1440, 1840, 2240
	Cyprus	Cypradio	35°03'N	33°17'E	518	200	M	0200, 0600, 1000, 1400, 1800, 2200
	Egypt	Alexandria	31°12'N	29°52'E	518	350	N	0210, 0610, 1010, 1410, 1810, 2210
		Serapeum	30°28'N	32°22'E	4209.5	400	X	0750, 1150
	France	Toulon	43°06'N	05°59'E	518	250	W	0340, 0740, 1340, 1540, 1940, 2340
					490	250	S	0300, 0700, 1100, 1500, 1900, 2300
	Greece	Iraklion	35°20'N	25°07'E	518	280	H	0110, 0510, 0910, 1310, 1710, 2110
		Kerkyra	39°37'N	19°55'E	518	280	K	0140, 0540, 0940, 1340, 1740, 2140
		Limnos	39°52'N	25°04'E	518	280	L	0150, 0550, 0950, 1350, 1750, 2150
	Israel	Haifa	32°49'N	35°00'E	518	200	P	0020, 0420, 0820, 1220, 1620, 2020
	Italy	Roma	41°48'N	12°31'E	518	320	R	0250, 0650, 1050, 1450, 1850, 2250
		Augusta	37°14'N	15°14'E	518	320	V	0330, 0730, 1130, 1530, 1930, 2330
		Cagliari	39°14'N	09°14'E	518	320	T	0310, 0710, 1110, 1510, 1910, 2310
		Trieste	45°41'N	13°46'E	518	320	U	0320, 0720, 1120, 1520, 1920, 2320
	Malta	Malta	35°49'N	14°32'E	518	400	O	0220, 0620, 1020, 1420, 1820, 2220

NAV Area	Country /Region	Station	Latitude	Longitude	Freq. (kHz)	Area (nm)	Station ID	Broadcast Schedule (UTC)	
III	Russian Federation	Novorossiysk	44°42'N	37°44'E	518	300	A	0300, 0700, 1100, 1500, 1900, 2300	
	Spain	Cabo de la Nao	38°43'N	00°09'E	518	300	X	0350, 0750, 1150, 1550, 1950, 2350	
	Turkey	Istanbul	41°04'N	28°57'E	518	300	D	0030, 0430, 0830, 1230, 1630, 2030	
		Samsun	41°17'N	36°20'E	518	300	E	0040, 0440, 0840, 1240, 1640, 2040	
		Antalya	36°53'N	30°42'E	518	300	F	0050, 0450, 0850, 1250, 1650, 2050	
	Ukraine	Izmir	38°22'N	26°36'E	518	300	I	0120, 0520, 0920, 1320, 1720, 2120	
Mariupol		47°06'N	37°33'E	518	280	B	0100, 0500, 0900, 1300, 1700, 2100		
IV	Bermuda(UK)	Odesa	46°29'N	30°44'E	518	280	C	0230, 0630, 1030, 1430, 1830, 2230	
		Bermuda	32°23'N	64°41'W	518	280	B	0010, 0410, 0810, 1210, 1610, 2010	
	Canada	Riviere-au-Renard	50°11'N	66°07'W	518	300	C	0020, 0420, 0820, 1220, 1620, 2020	
		Warton	44°20'N	81°10'W	518	300	H	0110, 0510, 0910, 1310, 1710, 2110	
		St. Johns	47°30'N	52°40'W	518	300	O	0220, 0620, 1020, 1420, 1820, 2220	
		Thunder Bay	48°25'N	89°20'W	518	300	P	0230, 0630, 1030, 1430, 1830, 2230	
		Sydney, NS		46°10'N	60°00'W	518	300	Q	0240, 0640, 1040, 1440, 1840, 2240
								J	0255, 0655, 1055, 1455, 1855, 2255
		Yarmouth		43°45'N	66°10'W	518	300	U	0320, 0720, 1120, 1520, 1920, 2320
								V	0335, 0735, 1135, 1535, 1935, 2335
		Labrador	53°42'N	57°01'W	518	300	X	0350, 0750, 1150, 1550, 1950, 2350	
		Iqaluit, NU		63°43'N	68°33'W	518	300	T	0310, 0710, 1110, 1510, 1910, 2310
					490	300	S	0300, 0700, 1100, 1500, 1900, 2300	
	United States	Miami	25°37'N	80°23'W	518	240	A	0000, 0400, 0800, 1200, 1600, 2000	
		Boston	41°43'N	70°30'W	518	200	F	0445, 0845, 1245, 1645, 2045, 0045	
		New Orleans	29°53'N	89°57'W	518	200	G	0300, 0700, 1100, 1500, 1900, 2300	
		Portsmouth	36°43'N	76°00'W	518	280	N	0130, 0530, 0930, 1330, 1730, 2130	
		Isabella	18°28'N	67°04'W	518	200	R	0200, 0600, 1000, 1400, 1800, 2200	
		Savannah, GA	32°08'N	81°42'W	518	200	E	0040, 0440, 0840, 1240, 1640, 2040	
	Netherlands Antilles	Curacao	12°10'N	68°52'W	518	400	H	0110, 0510, 0910, 1310, 1710, 2110	
V	NIL								
VI	Argentina	Ushaia	54°48'S	68°18'W	518	280	M	0200, 0600, 1000, 1400, 1800, 2200	
		Rio Gallegos	51°37'S	65°03'W	518	280	N	0210, 0610, 1010, 1410, 1810, 2210	
		Comodoro Rivadavia	45°51'S	67°25'W	518	280	O	0220, 0620, 1020, 1420, 1820, 2220	
		Bahia Blanca	38°43'S	62°06'W	518	280	P	0230, 0630, 1030, 1430, 1830, 2230	
		Mar del Plata	38°03'S	57°32'W	518	280	Q	0240, 0640, 1040, 1440, 1840, 2240	
		Buenos Aires	34°36'S	58°22'W	518	560	R	0250, 0650, 1050, 1450, 1850, 2250	
	Uruguay	La Paloma		34°40'S	54°09'W	518	280	F	0050, 0450, 0850, 1250, 1650, 2050
					490	280	A	0000, 0400, 0800, 1200, 1600, 2000	
VII	Namibia	Walvis Bay	23°03'S	14°37'E	518	378	B	0010, 0410, 0810, 1210, 1610, 2010	
		Cape Town	33°40'S	18°43'E	518	500	C	0020, 0420, 0820, 1220, 1620, 2020	
	South Africa	Port Elizabeth	34°02'S	25°33'E	518	500	I	0120, 0520, 0920, 1320, 1720, 2120	
		Durban	30°00'S	31°30'E	518	500	O	0220, 0620, 1020, 1420, 1820, 2220	
VIII	India	Mumbai	19°05'N	72°50'E	518	250	G	0100, 0500, 0900, 1300, 1700, 2100	
		Madras	13°08'N	80°10'E	518	400	P	0230, 0630, 1030, 1430, 1830, 2230	
	Mauritius	Mauritius Radio	20°10'S	57°28'E	518	400	C	0020, 0420, 0820, 1220, 1620, 2020	
IX	Bahrain	Hamala	26°09'N	50°28'E	518	300	B	0010, 0410, 0810, 1210, 1610, 2010	
	Egypt	Serapeum	30°28'N	32°22'E	518	200	X	0350, 0750, 1150, 1550, 1950, 2350	
					4209.5	200	X	0750, 1150	
		Kosseir	26°06'N	34°17'E	518	400	V	0330, 0730, 1130, 1530, 1930, 2330	
	Iran	Bushehr	28°59'N	50°50'E	518	300	A	0000, 0400, 0800, 1200, 1600, 2000	
		Bandar Abbas	27°07'N	56°04'E	518	300	F	0050, 0450, 0850, 1250, 1650, 2050	
	Saudi Arabia	Jeddah	21°23'N	39°10'E	518	390	H	0705, 1305, 1905	
	Oman	Muscat	23°36'N	58°30'E	518	270	M	0200, 0600, 1000, 1400, 1800, 2200	
Pakistan	Karachi	24°51'N	67°03'E	518	400	P	0230, 0630, 1030, 1430, 1830, 2230		
X	NIL								
XI	China	Sanya	18°14'N	109°30'E	518	250	M	0200, 0600, 1000, 1400, 2200	
						518	250	N	0210, 0610, 1010, 1410, 2210
		Guangzhou	23°08'N	113°32'E	4209.5	250	N	0210, 0610, 1010, 1410, 2210	
						518	250	Q	0240, 0640, 1040, 1440, 2240
		Dalian	38°52'N	121°31'E	518	250	R	0250, 0650, 1050, 1450, 2250	

NAV Area	Country /Region	Station	Latitude	Longitude	Freq. (kHz)	Area (nm)	Station ID	Broadcast Schedule (UTC)	
XI	Indonesia	Jayapura	02°31'S	140°43'E	518	300	A	0000, 0400, 0800, 1200, 1600, 2000	
		Ambon	03°42'S	128°12'E	518	300	B	0010, 0410, 0810, 1210, 1610, 2010	
		Makassar	05°06'S	119°26'E	518	300	D	0030, 0430, 0830, 1230, 1830, 2030	
		Jakarta	06°06'S	106°54'E	518	300	E	0040, 0440, 0840, 1240, 1640, 2040	
	Japan	Otaru	43°19'N	140°27'E	518	400	J	0130, 0530, 0930, 1330, 1730, 2130	
		Kushiro	42°57'N	144°36'E	518	400	K	0140, 0540, 0940, 1340, 1740, 2140	
		Yokohama	35°14'N	139°55'E	518	400	I	0120, 0520, 0920, 1320, 1720, 2120	
		Moji	34°01'N	130°56'E	518	400	H	0110, 0510, 0910, 1310, 1710, 2110	
		Naha	26°05'N	127°40'E	518	400	G	0100, 0500, 0900, 1300, 1700, 2100	
	Korea, Republic of	Chukpyong		37°03'N	129°26'E	518	200	V	0330, 0730, 1130, 1530, 1930, 2330
						490	200	J	0130, 0530, 0930, 1330, 1730, 2130
		Pyongsan	35°36'N	126°29'E	518	200	W	0340, 0740, 1340, 1540, 1940, 2340	
						490	200	K	0140, 0540, 0940, 1340, 1740, 2140
	Malaysia	Penang	05°26'N	100°24'E	518	350	U	0320, 0720, 1120, 1520, 1920, 2320	
		Miri	04°28'N	114°01'E	518	350	T	0310, 0710, 1110, 1510, 1910, 2310	
		Sandakan	05°54'N	118°00'E	518	350	S	0300, 0700, 1100, 1500, 1900, 2300	
	Singapore	Singapore	01°25'N	103°52'E	518	400	C	0020-0030, 0420-0430, 0820-0830, 1220-1230, 1620-1630, 2020-2030	
	Thailand	Bangkok Radio	13°43'N	100°34'E	518	200	F	0050, 0450, 0850, 1250	
	United States	Guam	13°29'N	144°50'E	518	100	V	0100, 0500, 0900, 1300, 1700, 2100	
	Vietnam	Ho Chi Minh City		10°47'N	106°40'E	518	400	X	0350, 0750, 1150, 1550, 1950, 2350
					490	400	W	0340, 0740, 1140, 1540, 1940, 2340	
Haiphong		20°44'N	106°44'E	4209.5	400	W	0230, 0630, 1030, 1430, 1830, 2230		
Danang		16°05'N	108°13'E	518	400	K	0140, 0540, 0940, 1340, 1740, 2140		
Taiwan	Kaohsiung	22°29'N	120°25'E	518	216	P	0230, 0630, 1030, 1430, 1830, 2230		
Associate Member of IMO	Hong Kong	22°13'N	114°15'E	518	400	L	0150, 0550, 0950, 1350, 1750, 2150		
XII	Canada	Prince Rupert	54°20'N	130°20'W	518	300	D	0030, 0430, 0830, 1230, 1630, 2030	
		Tofino	48°55'N	125°35'W	518	300	H	0110, 0510, 0910, 1310, 1710, 2110	
	United States	San Francisco	37°55'N	122°44'W	518	350	C	0400, 0800, 1200, 1600, 2000, 2400	
		Kodiak	57°46'N	152°34'W	518	200	J	0300, 0700, 1100, 1500, 1900, 2300	
		Honolulu	21°22'N	158°09'W	518	350	O	0040, 0440, 0840, 1240, 1640, 2040	
		Cambria	35°31'N	121°03'W	518	350	Q	0445, 0845, 1245, 1645, 2045, 0045	
		Astoria	46°10'N	123°49'W	518	216	W	0130, 0530, 0930, 1330, 1730, 2130	
XIII	Russian Federation	Kholmsk	47°02'N	142°03'E	518	300	B	0010, 0410, 0810, 1210, 1610, 2010	
		Murmansk	68°46'N	32°58'E	518	300	C	0020, 0420, 0820, 1220, 1620, 2020	
		Arkhangelsk	64°51'N	40°17'E	518	300	F	0050, 0450, 0850, 1250, 1650, 2050	
		Astrakhan	45°47'N	47°33'E	518	250	W	0340, 0740, 1140, 1540, 1940, 2340	
XIV	NIL								
XV	Chile	Antofagasta	23°40'S	70°25'W	518	300	A	0400, 1200, 2000	
							H	0000, 0800, 1600	
		Valparaiso	32°48'S	71°29'W	518	300	B	0410, 1210, 2010	
							I	0010, 0810, 1610	
							C	0420, 1220, 2020	
		Talcahuano	36°42'S	73°06'W	518	300	J	0020, 0820, 1620	
							D	0430, 1230, 2030	
		Puerto Montt	41°30'S	72°58'W	518	300	K	0030, 0830, 1630	
							E	0440, 1240, 2040	
		Punta Arenas	53°09'S	70°58'W	518	300	L	0040, 0840, 1640	
					F	0450, 1250, 2050			
					G	0050, 0850, 1650			
XVI	Peru	Paita	05°05'S	81°07'W	518	200	S	0300, 0700, 1100, 1500, 1900, 2300	
		Callao	12°03'S	77°09'W	518	200	U	0320, 0720, 1120, 1520, 1920, 2320	
		Mollendo	17°01'S	72°01'W	518	200	W	0340, 0740, 1140, 1540, 1940, 2340	

2. NVX-1000/NVX-3000 CONFIGURATION

2.1 NVX-1000/NVX-3000 Outline

NVX-1000/NVX-3000 NAVTEX receiver conforms to the following international standards:

- IMO MSC.148(77)
- IMO MSC.508 (105)
- IMO MSC.302(87)
- ITU-R M540-2 (06/90)
- ITU-R M.625-4 (03/12)
- IEC 60945 [2002] incl Corr. 1
- IEC 61162 series
- IEC 61097-6
- IEC 62923-1
- IEC 62923-2
- IEC 62288

2.2 Configuration of NVX-1000/NVX-3000



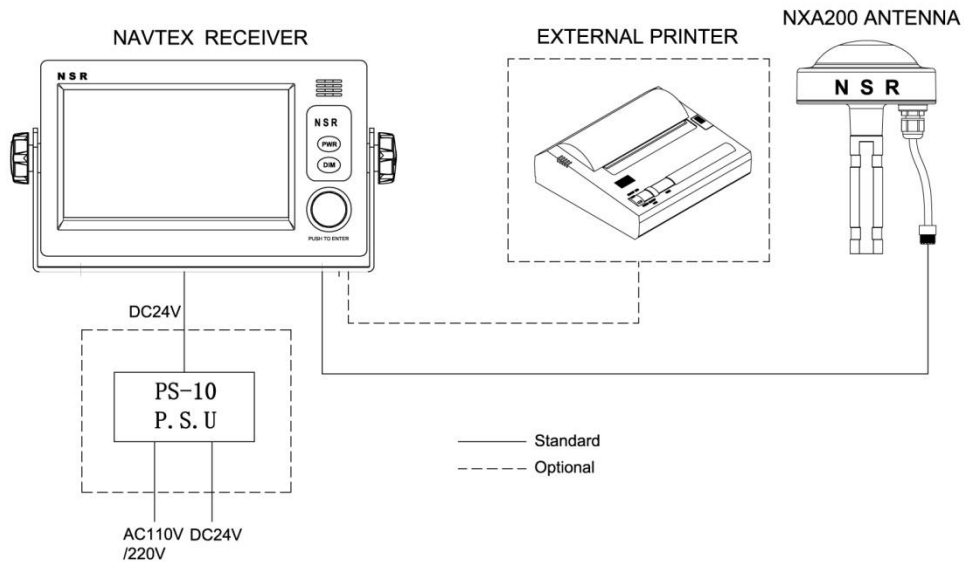





NVX-1000/NVX-3000 system consists of the main unit, active antenna, power supply unit (option), etc.



[Figure 2-1] System configuration of NAVTEX receiver

2.3 Supply scope of NVX-1000/NVX-3000

Table 2-1 Supply scope of NVX-1000/NVX-3000

Standard Supply Scope					
No	Name	Type	Part No.	Q'ty	Remarks
1	Main Unit	NVX-1000/ NVX-3000	N991110/ N991130	1 pc	
2	Loop Antenna (with 20 meters RG58 cable, TNC connector)	NXA200		1 pc	
3	Installation Materials				
3.1	Steel Tie			2 pc	
3.2	Screws (M5X20mm)			4 pc	
3.3	Earth Cord (1m)			1 pc	
4	User Manual			1 copy	
Option					
5	Thermal Printer	NPT-100	N993310	1 pc	
6	P.S.U (DC24V/AC110/220V IN, DC24V OUT)	PS-10	N993410	1 pc	
7	Flush-mount Bracket	NFB700A	N561070	1 pc	

Remark: Unless additionally ordered, optional items not included in the standard supply scope. Other power supplies that meet the requirements of Section 5.5 and comply with IEC-60945 can also be used.

3. NVX-1000/NVX-3000 SPECIFICATIONS

3.1 Software characteristics

3.1.1 B1 and B2 characters

The B1 characters identifying the different transmitter coverage areas and the B2 characters identifying the different types of messages are defined by IMO and chosen from table I of ITU-R Recommendation M.625, combination numbers 1-26.

- a) NVX-1000/NVX-3000 is capable of automatically rejecting unwanted information using character B1.
- b) NVX-1000/NVX-3000 is capable of disabling display of selected types of messages using character B2 with the exception of messages with B2 characters A, B, D and L.

3.1.2 B3 and B4 characters

B3 B4 is a two-character serial number, starting with 01 except in special cases where the serial number 00 is used.

3.1.3 Preamble

Message store is only being activated if the preamble B1 B2 B3 B4 is received without errors.

3.1.4 Repetition of display

Facilities are provided to avoid printing, storage or display of the same message several times on the same ship, when such a message has already been satisfactorily received.

The necessary information for these measures is deduced from the sequence B1 B2 B3 B4.

3.1.5 Mandatory display

A message shall always be stored and displayed if B3 B4 = 00 and if it is transmitted by a coast station that the equipment is programmed to select. The characters ZCZC B1 B2 B3 B4 need not be displayed.

3.1.6 Reception of messages with character errors

3.1.6.1 Messages with character error rate of > 4% and ≤ 33 %

NVX-1000/NVX-3000 stores the message, but will allow the message to be replaced if it is subsequently received with lower error rate.

NVX-1000/NVX-3000 will display the test messages indicating a character error rate of ≤ 33 %.

3.1.6.2 Messages with character error rate of > 33 %

NVX-1000/NVX-3000 will not store messages if the received character error rate > 33%.

3.1.7 Alarms

The receipt of search and rescue information (B2 = D) will give an alarm from NVX-1000/NVX-3000. It is only be possible to reset this alarm manually.

NVX-1000/NVX-3000 contains an integral alarm buzzer or/and a pair of relay contacts for the provision of an external sounder.

The alarms provided at NVX-1000/NVX-3000 indicate, A\B\L messages and any messages, and it can be suppressed by setting in menu.

3.1.8 Test facilities

NVX-1000/NVX-3000 is provided with a facility to test that the radio receiver, the display device and non-volatile message memory are functioning correctly.

3.2 Hardware Specifications

1) RF receiving part

- Receiving Frequencies: 518kHz, 490kHz & 4209.5kHz, receiving on three frequencies simultaneously
- Sensitivity: Better than -107dBm
- Selectivity:
 - ≥300Hz (6dB bandwidth)
 - ≤2kHz (60dB bandwidth)
- Leakage emission: ≤4nW (50Ω DUMMY antenna)
- Protection of input circuit: Withstanding 30Vrms of RF signal
- Self-diagnosis function: Frequencies generator
518kHz ±85Hz, 490kHz ±85Hz, 4209.5kHz ±85Hz

2) Environmental condition

- Operating temperature: -20°C~+55°C
- Storage temperature: -30°C~+70°C
- Humidity: Up to 93% RH at 40°C temperature
- Vibration: Up to 1G at 50Hz, tallying IEC60945
- Waterproof grade: IP22 (main unit), IP66 (antenna)
- Compass safe distance: 1.15m (standard)

3) Power supply

- Rating input voltage: DC 24V (range 21.6V~31.2V, 10Watts average)

4) Loop antenna

- Type: NXA200
- Frequency: 518kHz, 490kHz, 4209.5kHz
- Radiation pattern: Omni-directional
- Impedance: 50 Ω ,TNC
- Temperature range: For operation -30°C ~ +55°C

5) LCD

- Features: 7 inch, color LCD, touch screen operation with adjustable brightness
- Resolution: 800 × 480
- Dimension: 154 (W) × 87 (H) mm

6) Interface

- Input sentences of NMEA IN port: ZDA, RMC
- Input sentences of BAM/INS port: NRM, CQR, ACK, ACN, HBT
- Output sentences of BAM/INS port: ALR, NRX, NRM, ACN, ACK, ALF, ALC, ARC
- Ethernet port: Not used, reserved for future use

7) **Size:** 264 (W) × 145 (H) × 83 (D) mm (main unit)

8) **Weight:** About 2.3kg (main unit)

4. HOW TO OPERATE

4.1 Basic Operation

4.1.1 Outline of main unit

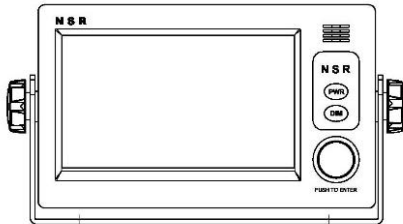

- Front View -

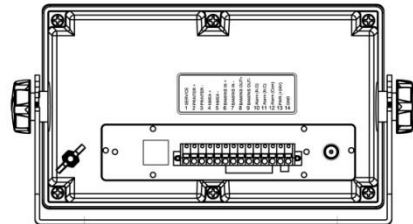

- Rear View -

[Figure 4-1] The outline of NVX-1000/NVX-3000 main unit

NVX-1000/NVX-3000 can be operated by touch-screen or key & knob on panel.

4.1.2 Power On / Off

By pressing the **PWR** key to switch on the NVX-1000/NVX-3000 receiver. The start-up window **[MSG LIST]** will appear on the screen.

ID	DATE	TIME	SIZE	STATE	
>WA03	04/02	00:40	10	✉	
WDD2	04/02	00:22	10	STOP	
WDD1	04/02	00:22	10	STOP	
WA12	04/01	05:12	10		
WA11	04/01	05:11	10	📎	
QB20	04/01	03:13	14		
QB19	04/01	02:42	14		
QA18	04/01	02:42	14		

TIME SYS 2024-04-02 00:41:11 UTC

[Figure 4-2] MSG list of default screen

If it's the first time to power on or the power has been switched off more than 72 hours, no messages will appear in the list except those locked before.

Hold down the **PWR** key 3 seconds to power off.

4.1.3 The default screen and control keys

The default display is the Message List screen - [MSG List], as below.

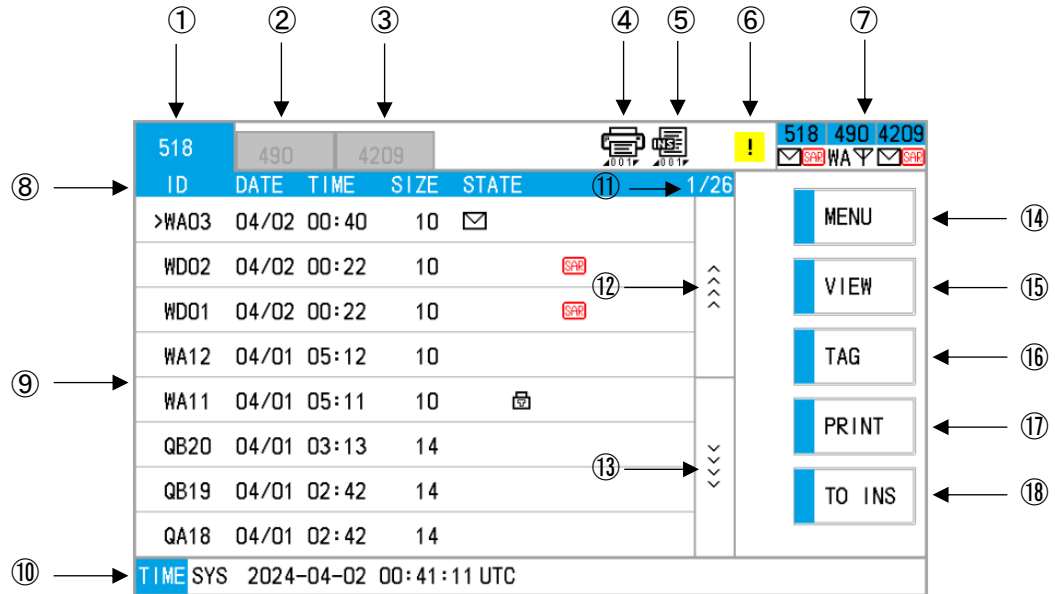



[Figure 4-3] The default screen

1	518	NAVTEX receiving frequency: 518 kHz
2	490	NAVTEX receiving frequency: 490 kHz
3	4209	NAVTEX receiving frequency: 4209.5 kHz
4		Current PRINT quantity
5		Current TO INS quantity
6		Alert Icon. Click to visit the alert list quickly. Icon is not displayed while there is no alert.
7	518 490 4209 	Having Search and Rescue information in different frequency. The antenna indication means the signal is being received on the frequency.
8	ID:	Message ID
	DATE:	Date when the message was received
	TIME:	Time when the message was received
	SIZE:	Character number of the message
	STATE:	: New message, not read yet : TAG message : SAR message, the second character of ID No. is "D" which means Search and Rescue.
9	Message list	Message list
10	TIME SYS	Time source, system time or GPS time
11	1/26	sequence number / Message quantity

12	>>>	Page up
13	<<<	Page down
14	MENU	To [MAIN MENU]
15	VIEW	To [VIEW MESSAGE]
16	TAG	To tag the selected message
17	PRING	To print the selected message
18	TO INS	To INS the selected message

The available keys are as follows.

Panel Button	Description
	Turn to select an item. Press to confirm the selection or input.
	Power ON/OFF. To power OFF, press and hold this key more than 3 seconds.
	Press to change the LCD brightness which can be adjusted by “1~12”.

4.1.4 Main Menu structure

Click **[MENU]** in **[MSG LIST]**, the following screen will be displayed.

The specific setup method is explained in detail in Section **4.3 main menu setting**.

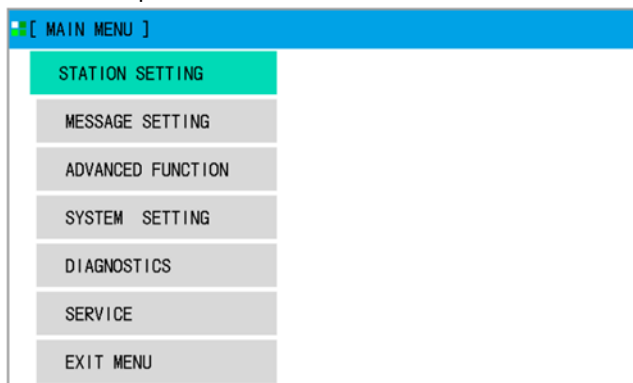

[Figure 4-4] Main menu screen

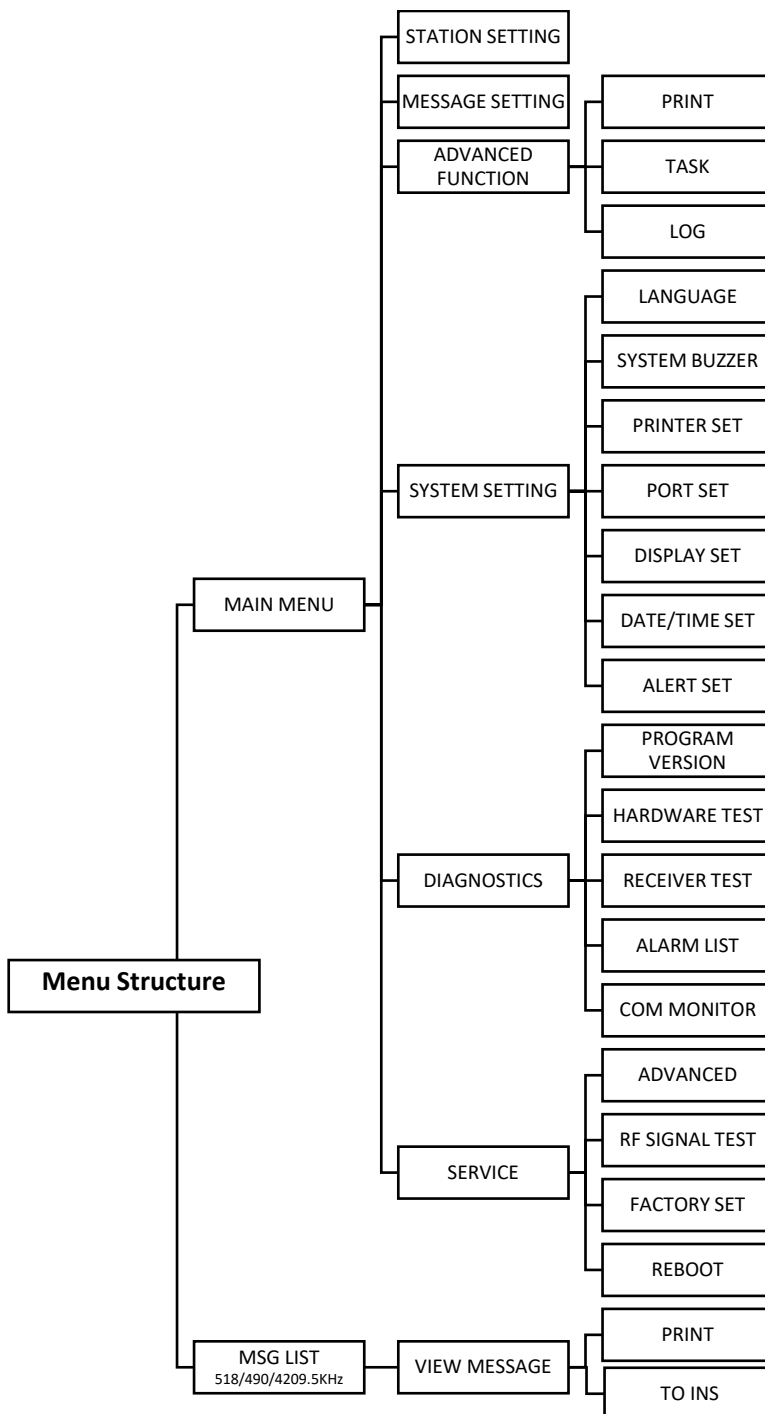

[Figure 4-5] Menu structure

4.2 Message operation

4.2.1 Message list

NVX-1000/NVX-3000 receives the maritime safety information on 518kHz, international NAVTEX frequency 490kHz and 4209.5kHz, national NAVTEX frequencies.

- When a message is received and stored, a message line will be added into the message list.
- If the antenna indication ∇ is flickering upper the screen, the signal is being received on the frequency
- In the message line, the message ID [QH08] is displayed together with date/time/size/state.

The ID format is explained in **[1-3 NAVTEX message format]**.

In the screen, totally 8 messages have been received.

The latest received message is situated in the first line.

ID	DATE	TIME	SIZE	STATE	
>WA03	04/02	00:40	10	✉	
WDO2	04/02	00:22	10	ERR	
WDO1	04/02	00:22	10	ERR	
WA12	04/01	05:12	10		
WA11	04/01	05:11	10	📷	
QB20	04/01	03:13	14		
QB19	04/01	02:42	14		
QA18	04/01	02:42	14		

TIME SYS 2024-04-02 00:41:11 UTC

[Figure 4-6] Message list screen

[MSG List] offers five sub items: **MENU**, **VIEW**, **TAG**, **PRINT** and **TO INS**.

4.2.2 Message view

In [MSG List], click the message you select, an arrow will appear. And click the message again, then enter the **[VIEW MESSAGE]** screen. Or when the arrow points to the message, click **VIEW** and then enter the **[VIEW MESSAGE]** screen.

[VIEW MESSAGE]		
PAGE	ZJ0249 EAST CHINA SEA M/T JIU HUA SHAN	BACK
01/01	PASS THE	
FREQ		PREV.
518	DREDGED DEEP-CHANNEL OUTSIDE XIAZHIMEN	
ID	FAIRWAY VIA 29-41.26N/122-31.31E 29-41.	NEXT
QAD1	55N/122-30.21E 29-43.88N/122-21.39E 29-	
TIME-UTC	44.28N/122-19.86E	PRINT
02-03		
02:48	AND 29-45.30N/122-18.50E FROM 280545UTC	TO INS
SIZE	TO 280645UTC APR ENTRANCE PROHIBITED	
287	ZHEJIANG	
CER		
00%	MSA CHINA	
STATE	NNNN	
📷		
CONTENT	NAVIGATIONAL WARNING	

[Figure 4-7] View message screen



Click **BACK** to return to **[MSG List]**.

4.2.3 Message tag

In **[MSG List]**, when the arrow points to the message, click **[TAG]**, you can Lock and save a message permanently. click **[TAG]** again to release the lock of message.

In NVX-1000/NVX-3000, after 72 hours since a message was received (including the shutdown time), the message will be automatically deleted.

Even within 72 hours, the message will also be deleted if the total memory is overloaded, maximum 200 messages for a single frequency.

While **[TAG]**, the message can be locked to retain, free from 72-hour and 200-message capacity constraints. While **[TAG]**,  appears in **[STATE]** column of **[MSG LIST]**. Also,  appears at the left of the **[VIEW MESSAGE]** screen.

4.2.4 Message print

In NVX-1000/NVX-3000, you can print the messages in two ways:

- **Automatic printing**

In the **[STATION SETTING]** and **[MESSAGE SETTING]** menu, you can choose D₁ and D₂ to define specific messages to be automatically printed out while a printer is connected.



For [automatic printing], please refer to Section 4.4 [STATION SETTING] and [MESSAGE SETTING].

- **Manual printing**

In the **[MSG LIST]** and **[VIEW MESSAGE]** screen, click **[PRINT]** to print out the current message contents displayed.

In addition to printing the message which is being browsed, NVX-1000/NVX-3000 also offers **[ADVANCED function]** features, including:

- PRINT
- TASK
- LOG



All the messages to be printed should be those messages which have been received and stored in the memory.

4.2.5 Message to INS

In the **[MSG LIST]** and **[VIEW MESSAGE]** screen, click **[TO INS]** to output the current message.

4.3 Main Menu Operation

From the default screen **[MSG List]**, click **[MENU]**, **[Main Menu]** will be displayed. There are six function items in **[MAIN MENU]**.

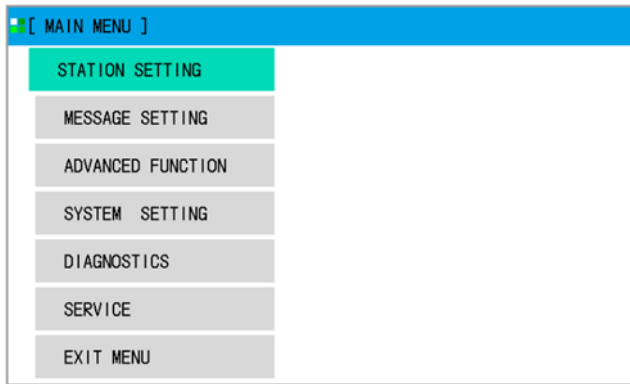

[Figure4-8] Main menu screen

4.3.1 Station Setting

It's to select certain stations to reject the messages broadcasted.



If you set the configuration by NRM commands, the configuration page does not refresh automatically. You need to exit and re-enter to view the new configuration

Click [STATION SETTING] to enter the following screen.

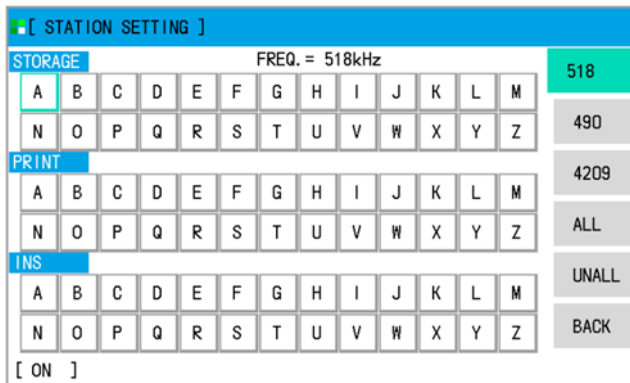

[Figure4-9] Station setting screen (1)

On each frequency, a station ID can be set for receiving rejection, automatic printing and output to INS.

By clicking to select or cancel the character, when the character turn grey and the bottom change from [ON] to [OFF], it means the setting is completed.

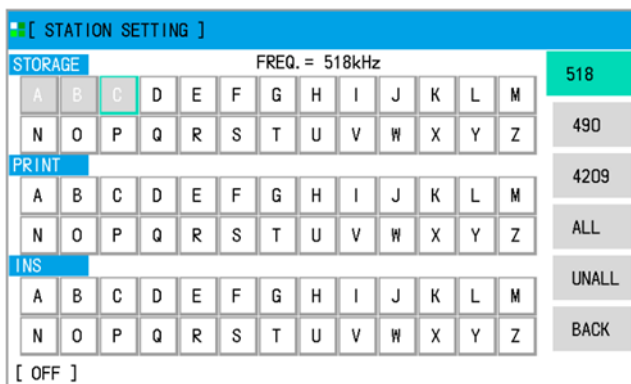

[Figure4-10] Station setting screen (2)

After finishing all settings for each frequency, click **BACK** to escape to previous menu.



The default setting is like that all stations are not rejected to receive while all automatic printing and output to INS are disabled.

4.3.2 Message Setting

Messages received from the stations not rejected as preset in **[STATION SETTING]** will be saved or not saved in the memory depending on **[MESSAGE SETTING]**.

Only those message types selected in **[MESSAGE SETTING]** will be properly stored.

Click **[MESSAGE SETTING]** at **[MAIN MENU]** to enter the following screen.

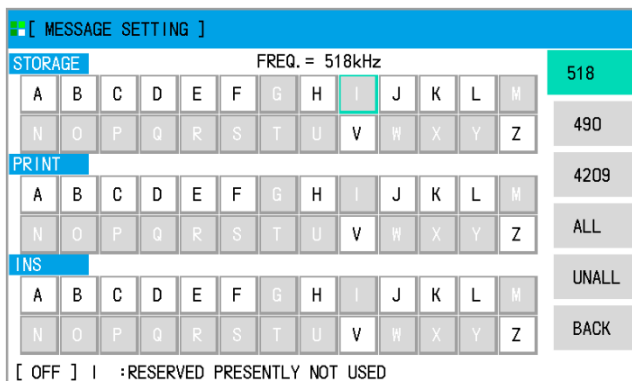

[Figure4-11] Message setting screen (1)

On each frequency, a message type ID can be set for saving rejection, automatic printing and output to INS.

By clicking to select or cancel the character, when the character turn grey and the bottom change from **[ON]** to **[OFF]**, it means the setting is completed.



In the message type, A/B/D/L can not be rejected. It's compulsory for NVX-1000/NVX-3000 to store A/B/D/L messages.

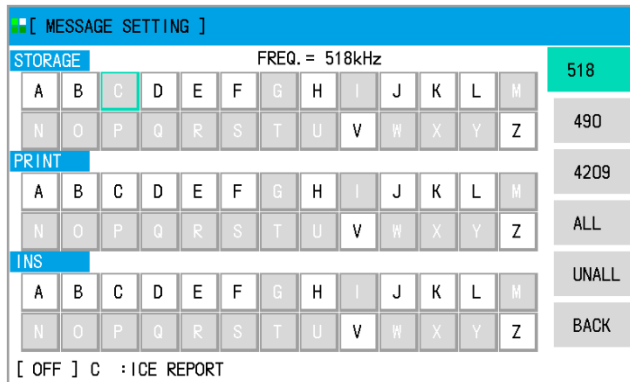

[Figure4-12] Message setting screen (2)

After finishing all settings for each frequency, click **BACK** to escape to previous menu.



The default setting is like that all message types are not rejected to store while all automatic printing and output to INS are disabled.

4.3.3 Advanced function

Click **[ADVANCED FUNCTION]** at **[MAIN MENU]** to enter the following screen.

In **[ADVANCED FUNCTION]**, it offers three sub function items: **PRINT**, **TASK**, **LOG**.

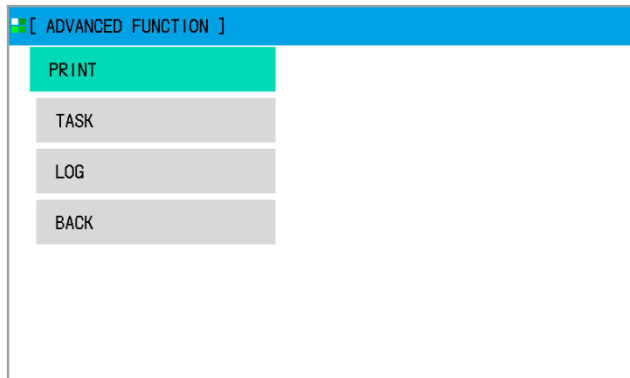

[Figure4-13] Advanced function screen

Click **PRINT** to enter **[ADVANCED PRINT]**. It's to print all messages sent by selected frequency, station and message. When the character is selected, it turns green.

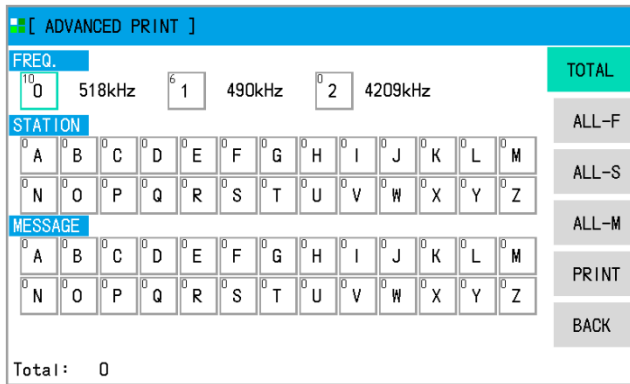

[Figure4-14] Advanced print screen (1)

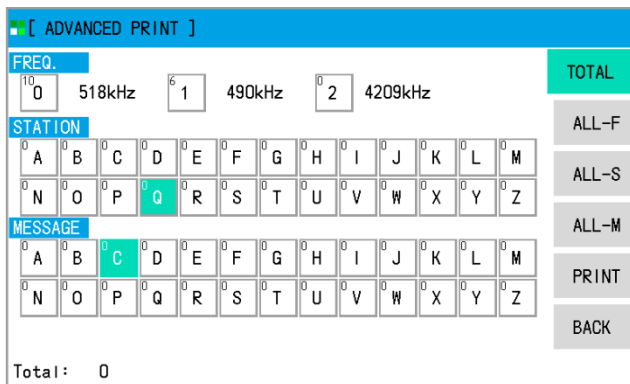

[Figure4-15] Advanced print screen (2)

Click **PRINT**, [CONFIRM] window will appear, select it.

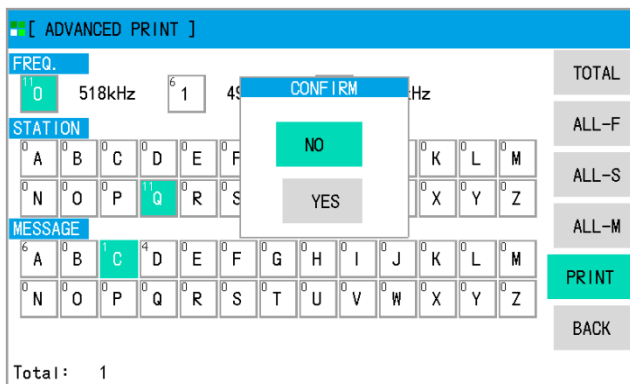

[Figure4-16] Advanced print screen (3)

Click **TASK** to enter the [TASK] screen, it is to display all the **PRINT** and **TO INS** task list.

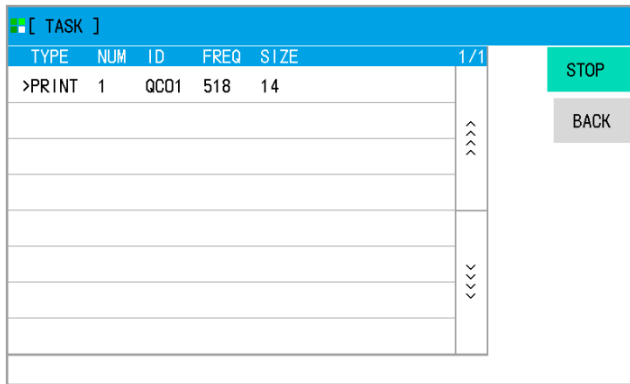

[Figure4-17] Task screen

Click **LOG** to enter the **[LOG]** screen, it is to display NAVTEX LOG.

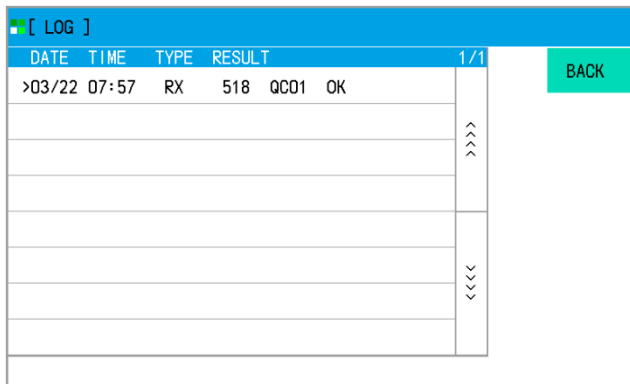

[Figure4-18] LOG screen

4.3.4 System Setting

NVX-1000/NVX-3000 contains seven system setting items as follows:

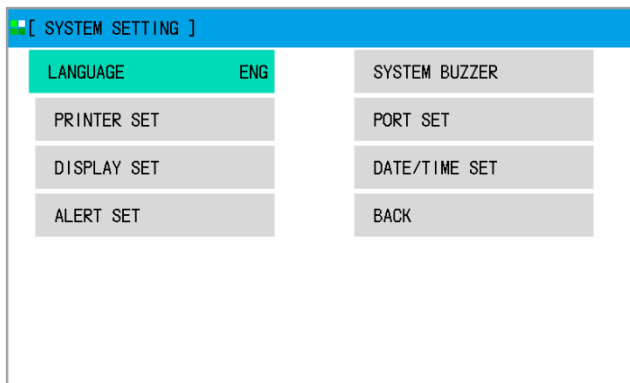

[Figure4-19] System setting screen

4.3.4.1 LANGUAGE

Click [LANGUAGE] to change language to English or Chinese.

4.3.4.2 SYSTEM BUZZER

Click [SYSTEM BUZZER] to enter the following view.

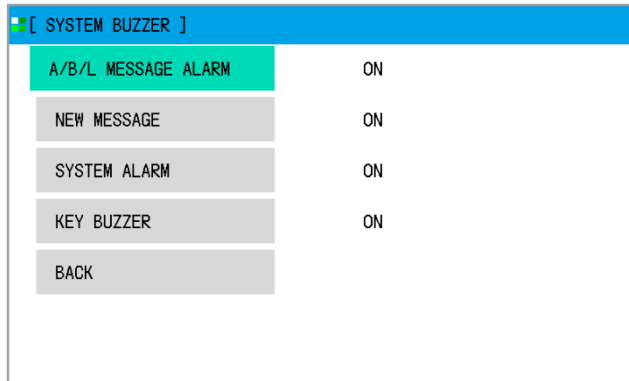

[Figure4-20] System buzzer screen

Click [A/B/L MESSAGE ALARM] to turn on or off alarms for A/B/L messages.

Click [NEW MESSAGE] to turn on or off alarms for new messages.

Click [SYSTEM ALARM] to turn on or off alarms for system.

Click [KEY BUZZER] to turn on or off the key sound.

4.3.4.3 PRINTER SET

Click [PRINTER SET] to enter the following view.

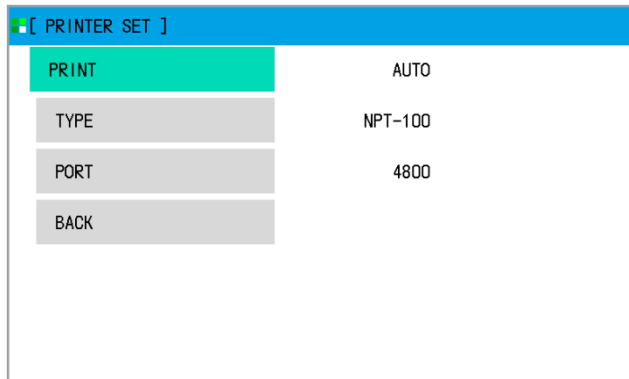

[Figure4-21] Printer set screen

Click [PRINT] to select automatic or manual printing.

Click [TYPE] to select printer type.

Click [PORT] to select the print port baud rate: 4800/9600/19200/38400/115200.

4.3.4.4 PORT SET

Click [PORT SET] to enter the following view.

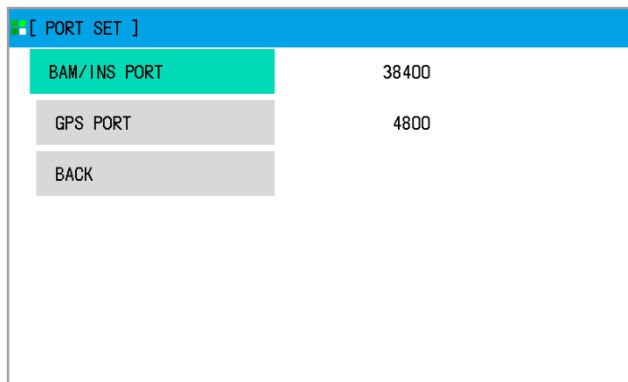

[Figure4-22] Port set screen

Click [BAM/INS PORT] to select the baud rate of the BAM/INS port:
4800/9600/19200/38400/115200.

Click [GPS PORT] to select the baud rate of the GPS port: 4800/9600/19200/38400/115200.

4.3.4.5 DISPLAY SET

Click [DISPLAY SET] to enter the following view.

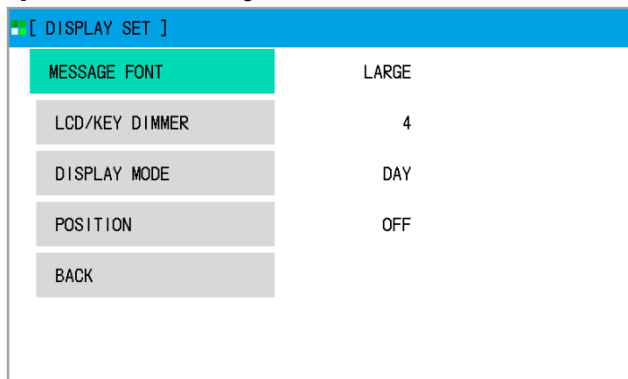

[Figure4-23] Display set screen

Click [MESSAGE FONT] to adjust the message font size.

Click [LCD/KEY DIMMER] to adjust the backlight brightness by 1 to 12 steps.

Click [DISPLAY MODE] to select day or night mode.

Click [POSITION] to select the position to show or not on the main screen.

4.3.4.6 DATE/TIME SET

Click [DATE/TIME SET] to enter the following view.

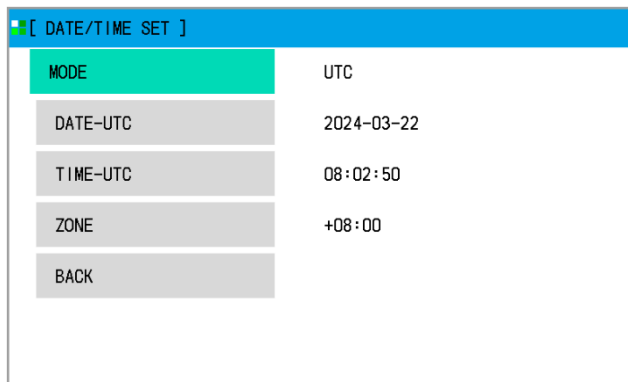

[Figure4-24] Date/Time set screen

Click [MODE] to select display UTC time or local time.

Click [DATE-UTC] to change date.

Click [TIME-UTC] to change time.

Click [ZONE] to change zone.



It's suggested to use UTC time instead of local time (LMT) when manually enter the date and time. If LMT is selected, it will be showed on the bottom right of Main screen.

4.3.4.7 ALERT SET

Click [ALERT SET] to enter the following view.

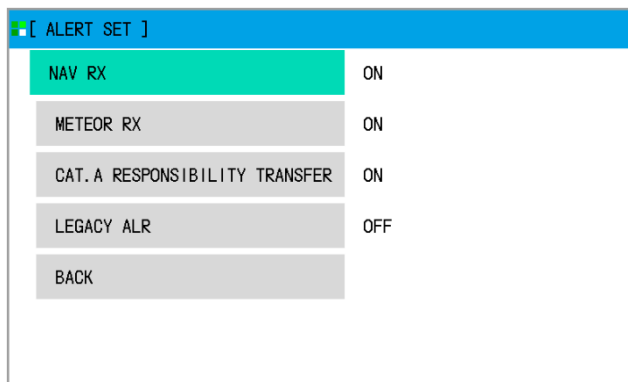

[Figure4-25] Alert set screen

[NAV RX]: When set to off, no alert will be generated when navigation messages are received. OFF by default.

[METEOR RX]: When set to off, no alert will be generated when meteorological messages are received. OFF by default.

[CAT.A RESPONSIBILITY TRANSFER]: when set to off, responsibility transfer for Class A alerts will be denied.

[LEGACY ALR]: When set to off, ALR sentences will not be output.

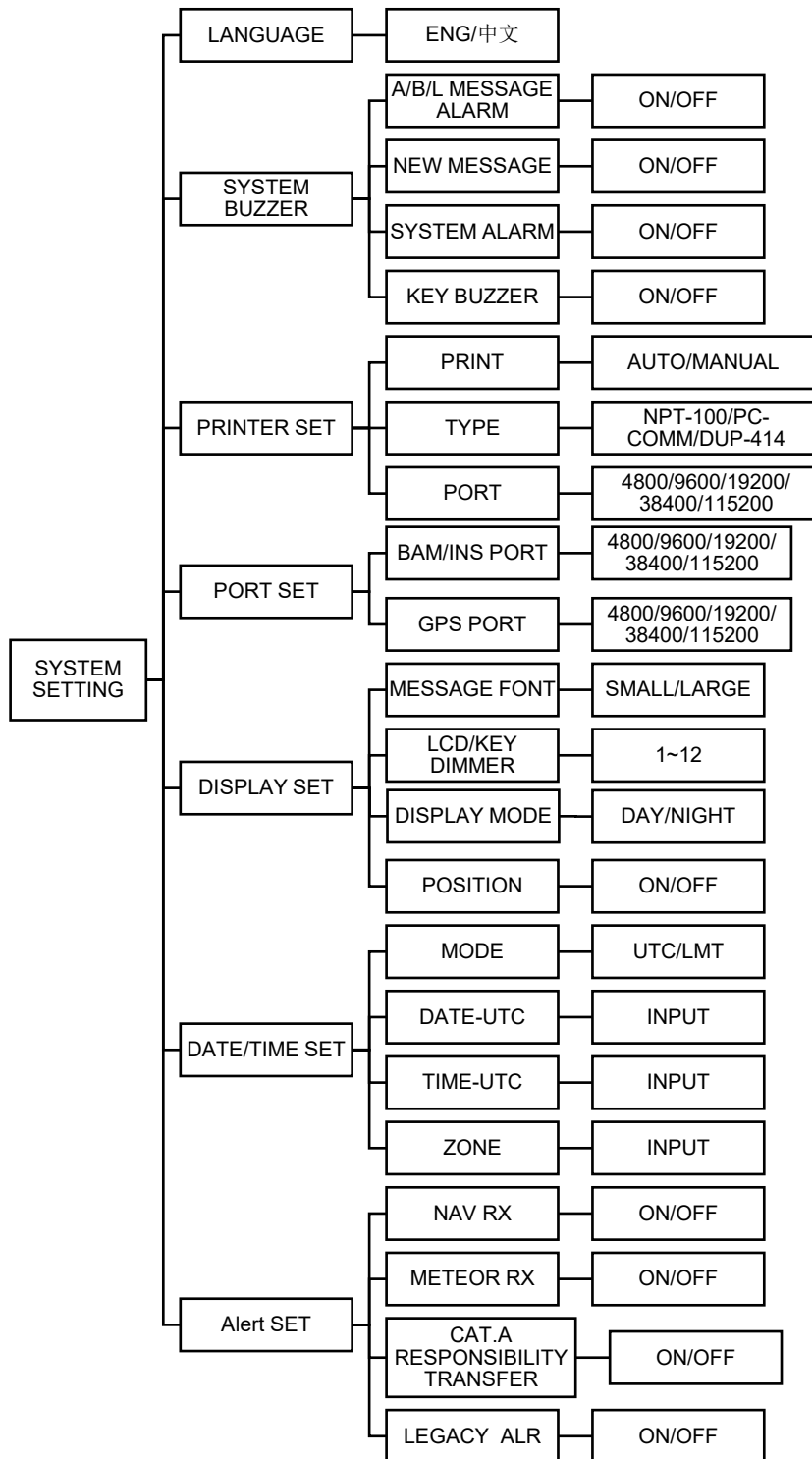

[Figure4-26] System setting menu structure



A list of user settings that are non-volatile.

- 1) Station Setting: B1 for Store, Print and INS in 518KHz, 490KHz and 4209.5KHz;
- 2) Message Setting: B2 for Store, Print and INS in 518KHz, 490KHz and 4209.5KHz;
- 3) MENU LANGUAGE;
- 4) A/B/L MESSAGE ALARM: ON or OFF;
- 5) NEW MESSAGE: ON or OFF;
- 6) SYSTEM ALARM: ON or OFF;
- 7) KEY BUZZER: ON or OFF;
- 8) PRINT MODE: AUTO or MANUAL;
- 9) PRINTER TYPE: NPT-100/PC-COMM/DUP414;
- 10) PRINTER PORT: 4800/96//38400/115200;
- 11) BAM/INS PORT: 4800/96//38400/115200;
- 12) GPS PORT: 4800/96//38400/115200;
- 13) MESSAGE FONT: LARGE/SMALL;
- 14) LCD/KEY DIMMER: 1-12;
- 15) TIME DISPLAY MODE: UTC/LMT;
- 16) TIME DATE;
- 17) TIME ZONE;
- 18) NAV RX Alert: ON or OFF;
- 19) METEOR RX Alert: ON or OFF;
- 20) CAT.A RESPONSIBILITY TRANSFER: ON or OFF;
- 21) LEGACY ALR Output: ON or OFF.

4.3.5 Diagnostics

NVX-1000/NVX-3000 diagnostics includes 5 items as follows:

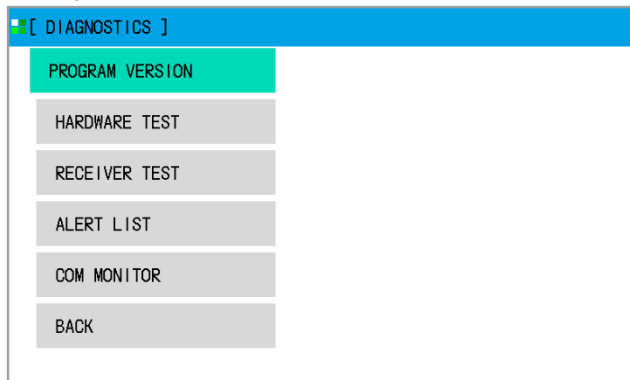

[Figure4-27] Diagnostics menu

4.3.5.1 PROGRAM VERSION

Click **[PROGRAM VERSION]** to enter the following view.

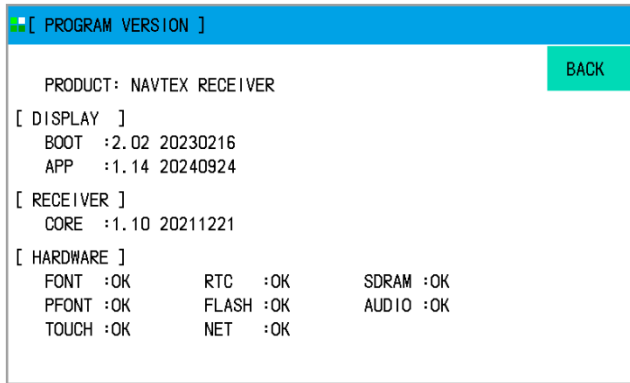

[Figure4-28] Program version screen

4.3.5.2 HARDWARE TEST

Click **[HARDWARE TEST]** to enter the following view.

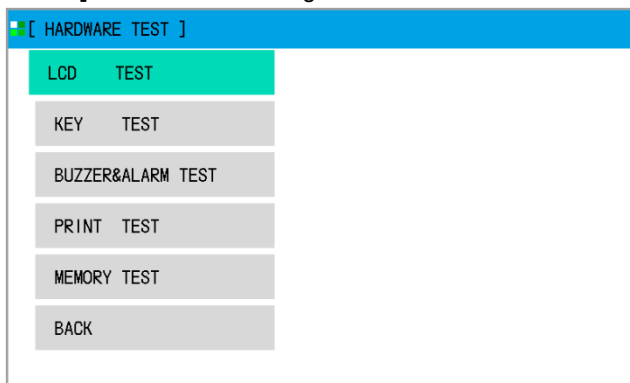

[Figure4-29 Hardware test screen

➤ LCD TEST

LCD TEST is designed to test whether the LCD is working or not.

Click **[LCD TEST]** to enter the test screen, turn knob continuously to test the LCD.

Press the knob to exit

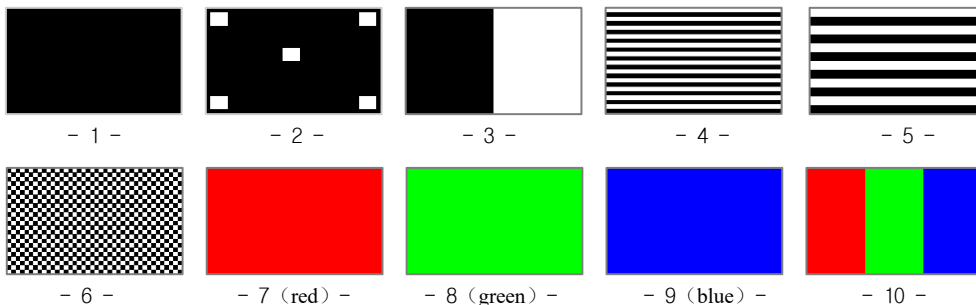

[Figure4-30] LCD test screen

➤ KEY TEST

KEY TEST is designed to test whether the key, knob and touch-screen are working or not.

Click **[KEY TEST]** to enter the following view.

KEY test: press the **[DIM]** key.

KNOB test: turn the knob to left and right, then press it.

TOUCH test: touch the screen anywhere three times.

If everything is good, OK icon will appear.

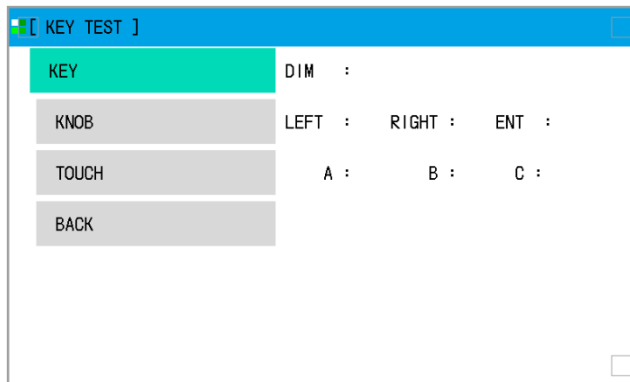

[Figure4-31] Key test screen

➤ BUZZER&ALARM TEST

BUZZER&ALARM TEST is designed to test whether the buzzer is working or not.

Built-in buzzer will sound when new message is received or an alarm is occurred.

Click **[BUZZER&ALARM TEST]** to enter the following view.

Click the icon, it will make different sound.

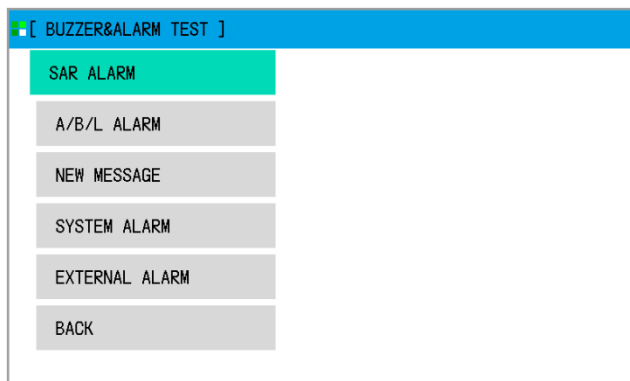

[Figure4-32] Buzzer & Alarm test screen

➤ PRINT TEST

PRINT TEST is designed to test whether the printer is working or not.

External printer is to be connected before this test function is carried out.

Click **[PRINT TEST]** to enter the following view.

Click **[PRINT]**, the printer will operate.

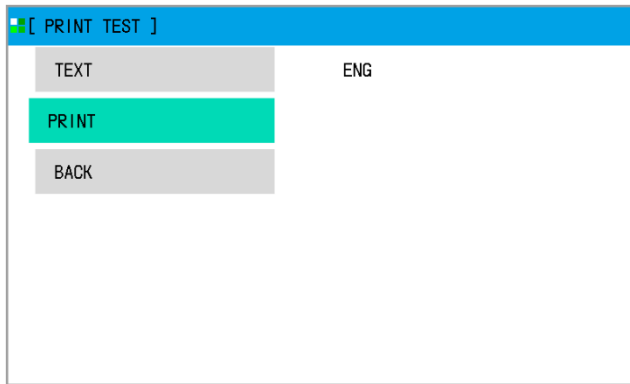

[Figure4-33] Printing test screen

➤ MEMORY TEST

[MEMORY TEST] is designed to test whether the memory is working or not.

Click [MEMORY TEST] to enter the following view.

When the [STATE] column appears [OK], it means the memory is good.

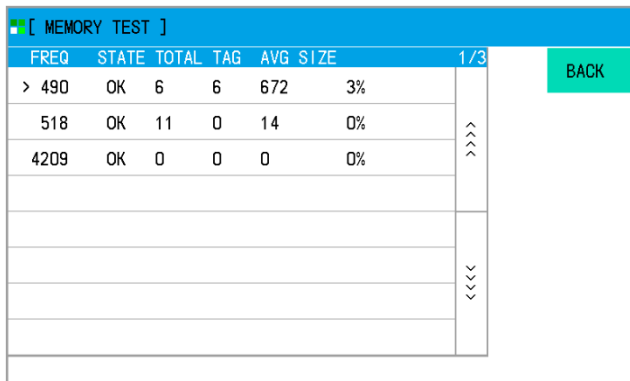

FREQ	STATE	TOTAL	TAG	AVG SIZE	1/3
> 490	OK	6	6	672	3%
518	OK	11	0	14	0%
4209	OK	0	0	0	0%

[Figure4-34] Memory test screen

4.3.5.3 RECEIVER TEST

Click [RECEIVER TEST] to enter the following screen.

[RECEIVER TEST] is to test the receiving performance with a built-in mini-transmitter.

The test order is 518kHz, 490kHz, 4209kHz. And the test output includes the reception state (STATE), ID, the characters number (SIZE) and error rate (CER).

When the receiver test is underway, the antenna icon twinkles on LCD screen.

The test will result in two states - OK and FAIL as shown above.

- **OK**: message received properly without any errors or the error rate less than 4%.
- **FAIL**: message not received or received message at the error rate more than 33%.

[RECEIVER TEST]						
FREQ	STATE	RESULT	ID	SIZE	CER	1/3
> 518	END	OK	XY01	70	00%	<div style="display: flex; flex-direction: column; align-items: center;"> <div style="background-color: #00b050; color: white; padding: 5px; margin-bottom: 5px;">START</div> <div style="background-color: #ccc; padding: 5px; margin-bottom: 5px;">BACK</div> </div>
490	END	OK	XY02	70	00%	
4209	END	OK	XY03	70	00%	
518 KHZ ABCDEFGHIJ KLMNOPQRST UVWXYZ1234 567890? : . , - () ' = / + NNNN						

[Figure4-35] Receiver test result screen

4.3.5.4 ALERT LIST

Click [ALERT LIST] to enter the following view.

[ALERT LIST] is to check alerts.

In the [ALERT LIST], there are four sub items: to view the alert, mute the alert, acknowledge and check the log.



Mute only temporarily silence the alerts for 30 seconds.

[ALERT LIST]				
ID	TIME	ALERT-TITLE	1/6	
> 3062	08:11	GENERAL FAULT	>>> >>>	<div style="background-color: #00b050; color: white; padding: 5px; margin-bottom: 5px;">VIEW</div>
3062	08:11	NAVTEX FAULT		<div style="background-color: #ccc; padding: 5px; margin-bottom: 5px;">MUTE</div>
3115	08:11	IMPAIRED RADIO		<div style="background-color: #ccc; padding: 5px; margin-bottom: 5px;">ACK</div>
3122	08:11	SAR RX	<<< <<<	<div style="background-color: #ccc; padding: 5px; margin-bottom: 5px;">LOG</div>
3123	08:11	METEOR RX		<div style="background-color: #ccc; padding: 5px; margin-bottom: 5px;">BACK</div>
3123	08:11	NAV RX		
TIME:UTC 2024-03-22 08:12:06				

[Figure4-36] Alert list screen



1. For SAR RX, category A, "ACK" operation is not available.
2. For "Warning" priority with unacknowledged/silenced state, "ACK" operation is available.
3. For SAR RX, NAV RX, and METEOR RX alert, can be reset in the [ALERT View] window.

Alert mark description:

MARK	PRIORITY	STATE
	WARNING	ACTIVE-UNACKNOWLEDGED
		ACTIVE-SILENCED
		ACTIVE-ACKNOWLEDGED
		ACTIVE-RESPONSIBILITY TRANSFERRED
		RECTIFIED-UNACKNOWLEDGED
	CAUTION	ACTIVE

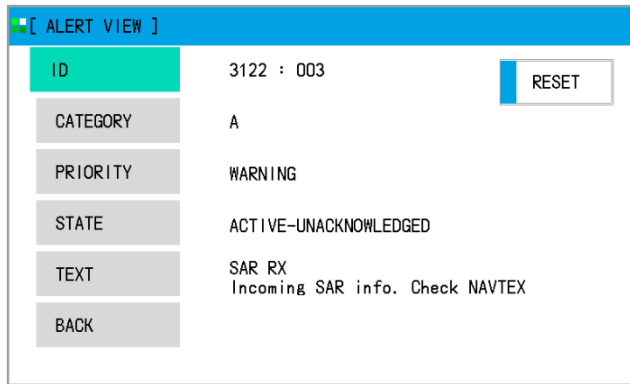

[Figure4-37] Alert view screen

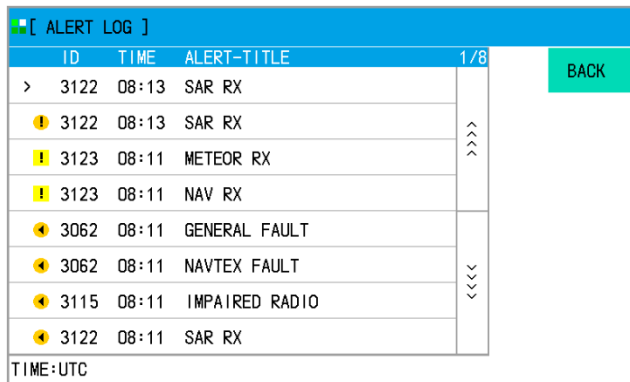

[Figure4-38] Alert log screen

Alert description:

NO.	ID	Instance	Category	Priority	ALF Title	ALF Description
1	3122	003	A	WARNING	SAR RX	Incoming SAR info. Check NVXTEX
2	3115	004	B	WARNING	IMPAIRED RADIO	NAVTEX: Receiver malfunction
3	3062	005	B	WARNING	NAVTEX FAULT	NAVTEX: Built in self test failure
4	3062	006	B	WARNING	GENERAL FAULT	NAVTEX: General failure
5	3123	001	B	CAUTION	NAV RX	NAVTEX: Navigational warning
6	3123	002	B	CAUTION	METEOR RX	NAVTEX: Meteorological warning

Alert configuration:

NO.	ID	Instance	Category	Priority	Escalation Properties	Permission Acknowledge	Permission Transfer of Responsibility
1	3122	003	A	WARNING	WARNING	YES	YES*
2	3115	004	B	WARNING	WARNING	YES	YES
3	3062	005	B	WARNING	WARNING	YES	YES
4	3062	006	B	WARNING	WARNING	YES	YES



The Responsibility Transfer permission can be set as on or off, default is on.

Responsibility Transfer:

If CAM sends Valid HBT and Responsibility Transfer command ACN,O, the status will change to Responsibility Transferred.

Cancel Responsibility Transfer:

If HBT is not received in timeout period or the validity flag is invalid, the status will change to Active-Unacknowledged.

4.3.5.5 COM MONITOR

Click **[COM MONITOR]** to enter the following view.

It's to check the sentence from BAM/INS and NMEA.

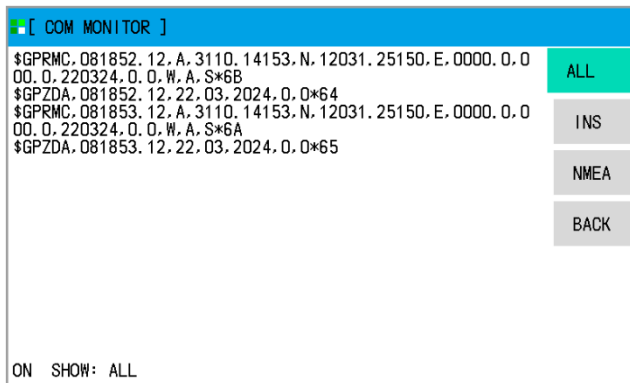

[Figure4-39] COM monitor screen

4.3.6 Service

Click **[SERVICE]** item at **[MAIN MENU]**. Input the password to enter the **[SERVICE]** screen.

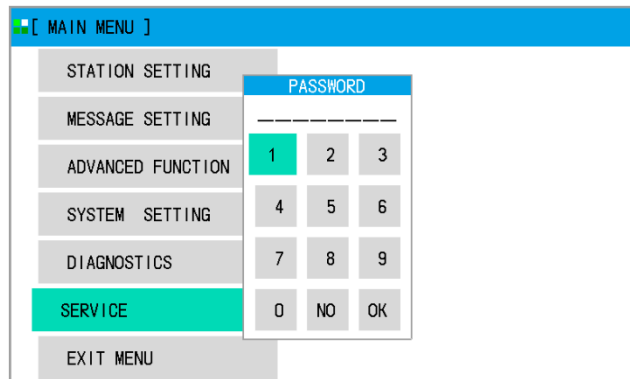

[Figure4-40] Service-Password enter

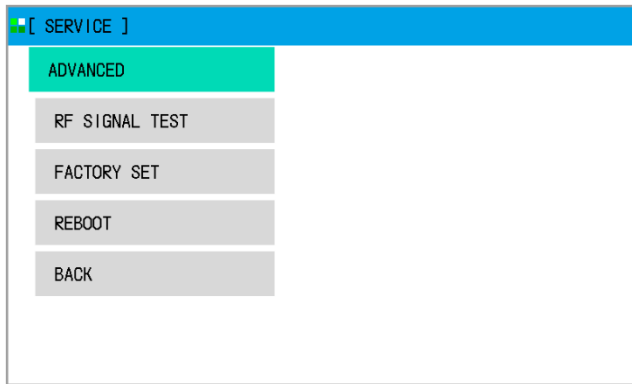

[Figure4-41] Service screen

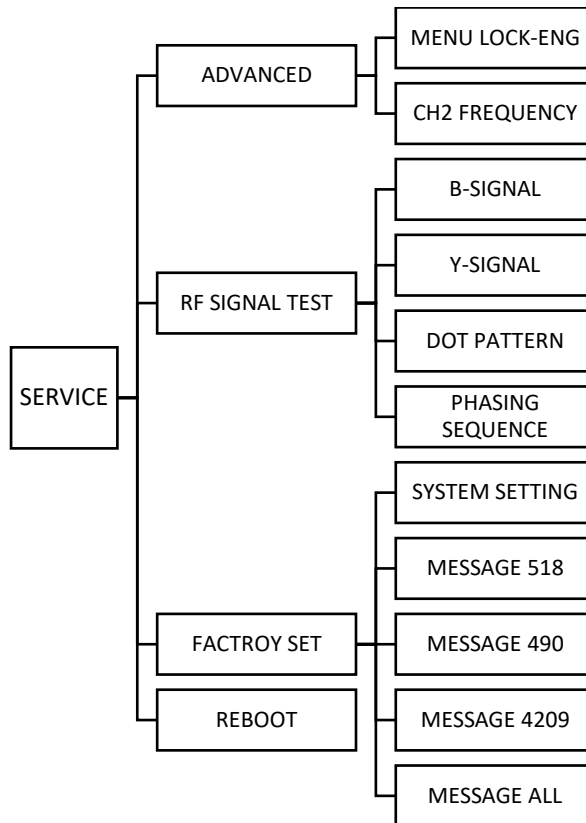

[Figure4-42] Service menu structure

5. INSTALLATION

5.1 Antenna

The NXA200 loop antenna connected to NVX-1000/NVX-3000, should be kept away from other transmitting elements to avoid damage although NVX-1000/NVX-3000 might withstand 30 volts of RF high voltages. Generally the NAVTEX antenna should be 6 meters away from the MF/HF antenna, and 1 meter from VHF antenna.

Working on MF/HF, NXA200 antenna does not need to be installed on high place.

The NXA200 antenna is supplied with a RG-58 cable of 20m.

After the antenna installed, tighten the cable connector and seal it with watertight rubber adhesive tape.

5.2 Main Unit

NVX-1000/NVX-3000 could be mounted on the table, on the wall, the bulkhead using the bracket supplied. For flush-type mount, refer to cutting drawing in this manual.

Select proper place to install the receiver to avoid sea water and don't be exposed to direct sunlight.

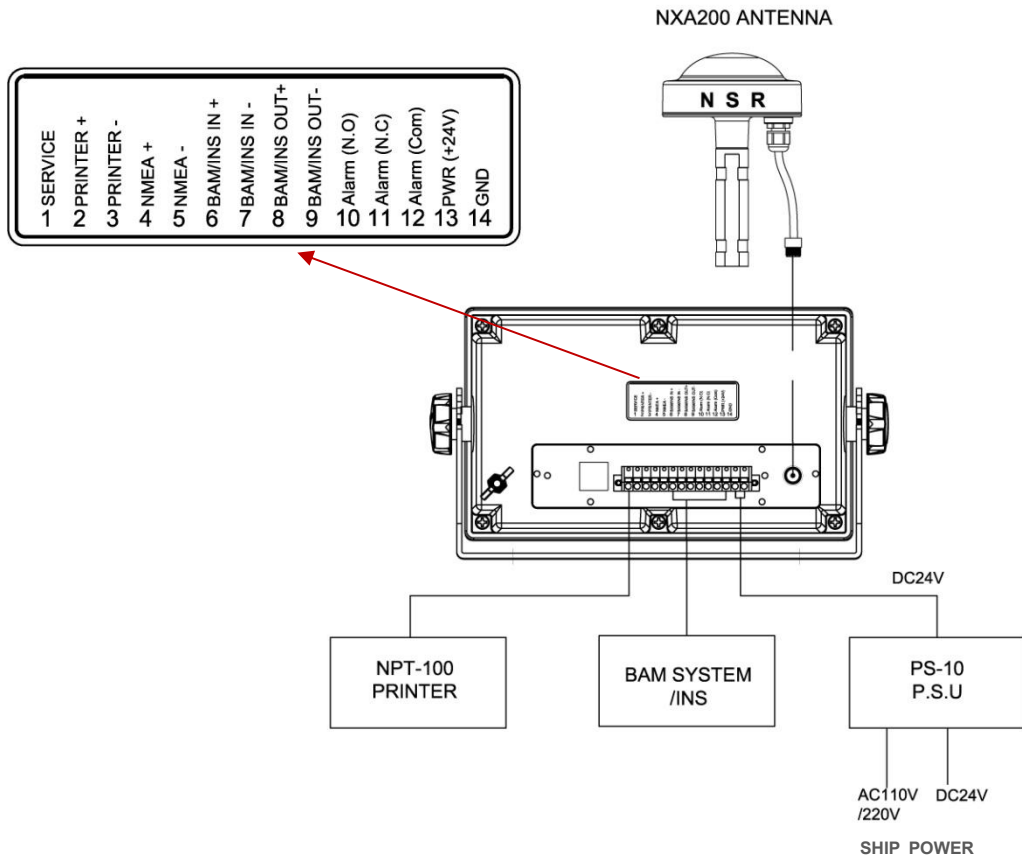

[Figure 5-1] Connection wiring diagram

5.3 BAM/INS connection

NVX-1000/NVX-3000 can be connected to BAM system/INS.

NVX-1000/NVX-3000 RS422		BAM system/INS RS422
Pin 6	BAM/INS IN (+)	OUT (+)
Pin 7	BAM/INS IN (-)	OUT (-)
Pin 8	BAM/INS OUT (+)	IN (+)
Pin 9	BAM/INS OUT (-)	IN (-)

5.4 External alarm

NVX-1000/NVX-3000 can be connected to external alarm system. When connected, the external alarm can play the same role as built-in buzzer to indicate the incoming messages.

Pin No.	Description
10	External Alarm (Normal Open)
11	External Alarm (Normal Close)
12	External Alarm (Common)

5.5 Power supply connection

The power supply to NVX-1000/NVX-3000 is +24VDC at least 1A. The allowed range is between +21.6VDC ~+31.2VDC. The shield cable is recommended to connect the NVX-1000/NVX-3000 to ship's power source.

Pin No.	Description
13	+ 24V
14	GND

5.6 Printer connection

As an optional device, NPT-100 is recommended as the printer used for NVX-1000/NVX-3000.

- Model No. : **NPT-100**
- Rating: **DC6.5V 15W**



[Figure5-2] Printer Connection

Necessary settings are needed for NPT-100 before properly working with NVX-1000/NVX-3000. Please refer to the manual supplied by the printer maker. The settings include the following parameters:

- **Serial port setting**

The output of NPT-100 should be set as SERIAL.

- **Baud rate setting**

The default rate for NVX-1000/NVX-3000 is 4800bps. If other rate except 4800bps is set for the printer, NVX-1000/NVX-3000 has to be set for the same rate in **[SERVICE]** menu.

5.7 Digital interface

Digital interface sentence -- IEC 61162-1& IEC 61162-2

Input sentences of NMEA IN port : ZDA, RMC

Input sentences of BAM/INS port : NRM, CRQ, ACK, ACN, HBT

Output sentences of BAM/INS port : ALR, NRX, NRM, ACN, ACK, ALF, ALC, ARC

Format of NMEA IN port and BAM/INS port

Baud rate: 4800 (NMEA IN default value); 38400 (BAM/INS default value)

Data bits: 8, parity none

Stop bits: 1

Ethernet port: Not used, reserved for future use.

APPENDIX 1 ALERT SOLUTION

NO.	ALERT	SOLUTION
1	NAV RX	NAVTEX MESSAGE notification, non-product failure.
2	METEOR RX	NAVTEX MESSAGE notification, non-product failure.
3	SAR RX	NAVTEX MESSAGE notification, non-product failure.
4	IMPAIRED RADIO	Restart it 1-3 times, If it fails to return to normal contact the manufacturer.
5	NAVTEX FAULT	Built in self test failure. Check failure information, contact manufacturer.
6	GENERAL FAULT	HW error. Check equipment, view the software version menu, contact the manufacturer.

APPENDIX 2 SENTENCE DISCRIPTION

ACK –Acknowledge alarm

\$--ACK,xxx*hh <CR><LF>



1. Unique alarm number (identifier) at alarm source

ACN – Alert command

\$--ACN,hhmmss.ss,aaa,x.x,x.x,c,a*hh <CR><LF>

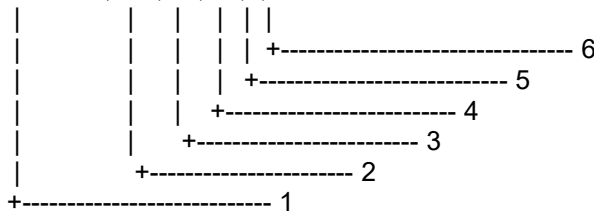

1. Time
2. Manufacturer's mnemonic code
3. Alert Identifier
4. Alert Instance, 0 to 999999
5. Alert command, A, Q, O or S
6. Sentence status flag

ALC - Cyclic alert list

\$--ALC,xx,xx,xx,x.x,aaa,x.x,x.x,x.x,,aaa,x.x,x.x,x.x*hh <CR><LF>

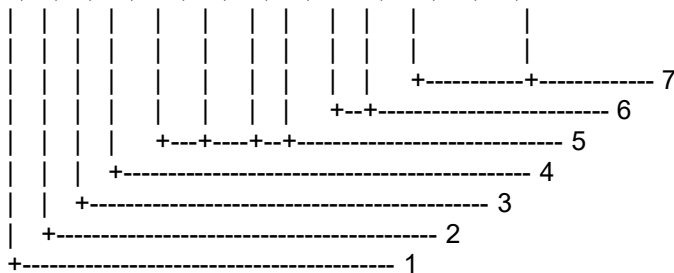

1. Total number of sentences for this message, 01 to 99
2. Sentence number, 01 to 99
3. Sequential message identifier, 00 to 99
4. Number of alert entries
5. Alert entry 1
6. Additional Alert entries
7. Alert entry n

ALF - Alert sentence

\$--ALF,x,x,x,hhmmss.ss,a,a,a,aaa,x,x,x,x,x,x,c--c*hh <CR><LF>

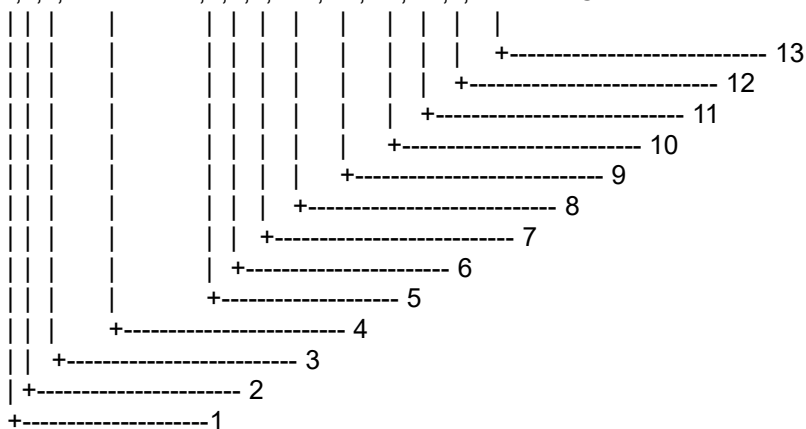

1. Total number of ALF sentences for this message, 1 to 2
2. Sentence number, 1 to 2
3. Sequential message identifier, 0 to 9
4. Time of last change, see NOTE A
5. Alert category, A, B or C
6. Alert priority, E, A, W or C
7. Alert state, A, S, N, O, U or V
8. Manufacturer's mnemonic code
9. Alert identifier
10. Alert instance, 0 to 999999
11. Revision counter, 1 to 99
12. Escalation counter, 0 to 9
13. Alert text

NOTE A: If the system time is out of sync with valid ZDA sentence, this filed is NULL.

ALR – Set alarm state

\$--ALR,hhmmss.ss,xxx,A,A,c--c*hh <CR><LF>

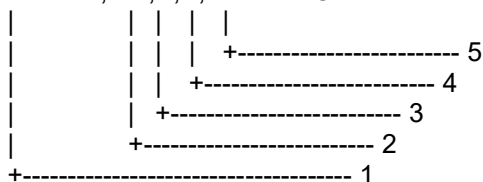

1. Time of alarm condition change, UTC
2. Unique alarm number (identifier) at alarm source
3. Alarm condition (A = threshold exceeded, V = not exceeded)
4. Alarm's acknowledge state, A = acknowledged, V = unacknowledged
5. Alarm's description text

ARC - Alert command refused

\$--ARC,hhmmss.ss,aaa,x.x,x.x,c*hh <CR><LF>

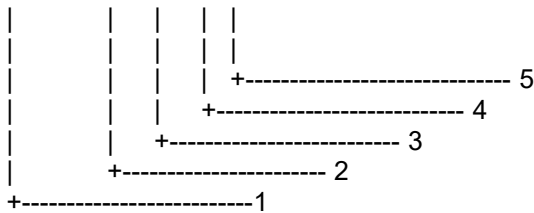

1. Time
2. Manufacturer's mnemonic code
3. Alert identifier
4. Alert instance, 1 to 999999
5. Refused alert command, A, Q, O or S

HBT – Heartbeat supervision sentence

\$--HBT,x.x,A,x*hh<cr><lf>



1. Configured repeat interval
2. Equipment status
3. Sequential sentence identifier

NRM – NAVTEX receiver mask

\$-- NRM,x,x,hhhhhhhh,hhhhhhhh,a*hh<CR><LF>

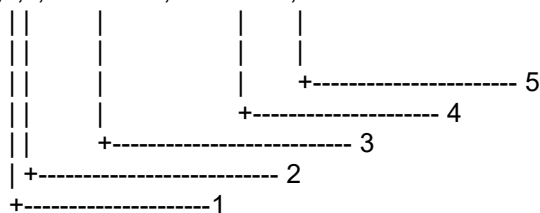

1. Function code, 0 to 9
2. Frequency table index, 1 to 9
3. Transmitter coverage area mask
4. Message type mask
5. Sentence status flag

When another device (for example an INS) wishes to set one or more of the bit masks it sends one or more NRM sentences to the NAVTEX receiver. When another device wishes to determine the current values of the bit masks, it sends a query sentence to the NAVTEX receiver as follows:

\$--INQ,NRM*hh<CR><LF>

On receiving this query, the NAVTEX receiver will respond with one NRM sentence for each mask type and frequency combination that it supports.

NRX – NAVTEX received message

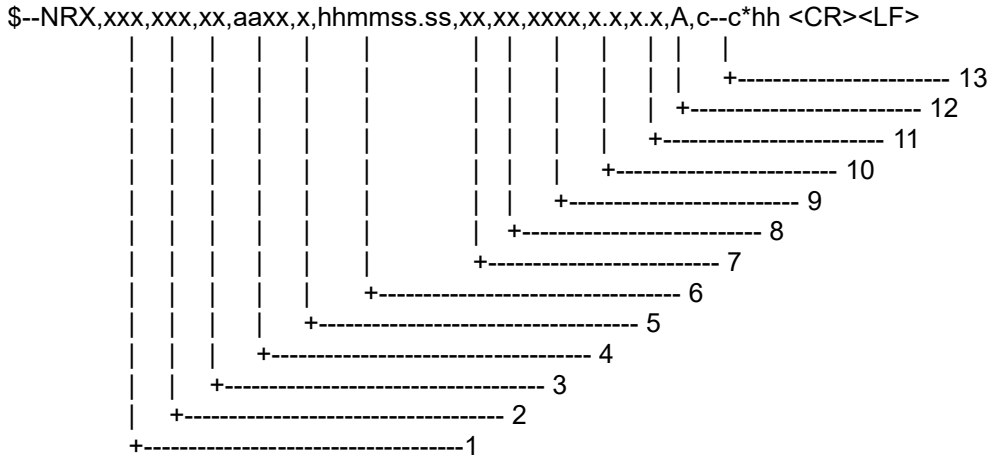

1. Number of sentences 001-999
2. Sentence number 001-999
3. Sequential message id 00-99
4. NAVTEX message code
5. Frequency table index 0-9
6. UTC of receipt of message
7. Day 1-31
8. Month 1-12
9. Year
10. Total number of characters in this series of NRX sentences
11. Total number of bad characters
12. Status indication
13. Message body

RMC- Recommended minimum specific GNSS data

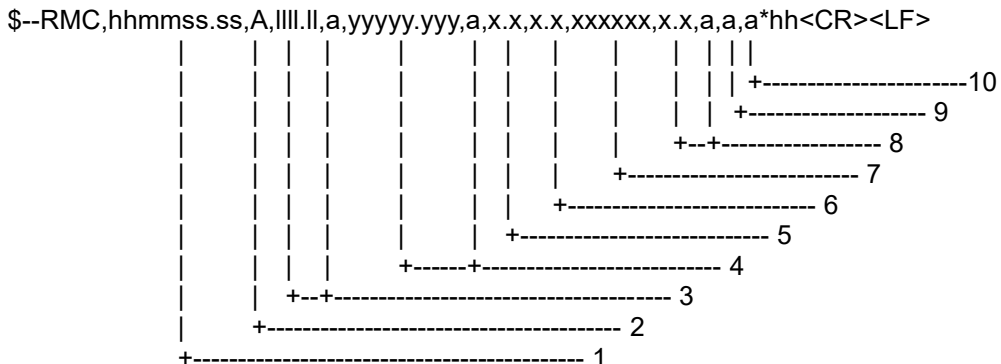

1. UTC of position fix
2. Status: A=data valid, V=navigation receiver warning
3. Latitude, N/S
4. Longitude, E/W
5. Speed over ground, knots
6. Course over ground, degrees true
7. Date: dd/mm/yy
8. Magnetic variation, degrees E/W
9. Mode indicator
10. Navigational status

ZDA - Time and date

\$--ZDA,hhmmss.ss,xx,xx,xxxx,xx,xx*hh<CR><LF>

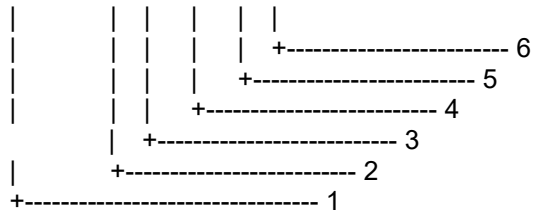

1. UTC
2. Day, 01 to 31 (UTC)
3. Month, 01 to 12 (UTC)
4. Year (UTC)
5. Local zone hours, 00h to ± 14 h
6. Local zone minutes, 00 to +59

APPENDIX 3 ABBREVIATIONS

Abbreviation	Term	Abbreviation	Term
ACK	Acknowledge	INS	Integrated Navigation System
ALARM	Alarm	LOG	Log
APP	Application	NAV	Navigational
AUTO	Automatic	NUM	Number
BAM	Bridge Alert Management	ON	On
COM	Communication	PWR	Power
ENG	English	RX	Receive
ENT	Enter	SAR	Search and Rescue information
FREQ.	Frequency	SYS	System

APPENDIX 4 INSTALLATION DRAWINGS

Drawing No.	Description
NVX1000/3000-ID-001	NVX1000/NVX-3000 NAVTEX SYSTEM DIAGRAM
NVX1000/3000-ID-002	NVX1000/NVX-3000 CONNECTION DIAGRAM
NVX1000/3000-ID-003	NVX1000/NVX-3000 NAVTEX RECEIVER WIRING DIAGRAM
NVX1000/3000-ID-004	NVX1000/NVX-3000 MAIN UNIT DIMENSION DRAWING
NVX1000/3000-ID-005	NVX1000/NVX-3000 MAIN UNIT MOUNT DRAWING (TABLE TYPE)
NVX1000/3000-ID-006	NVX1000/NVX-3000 MAIN UNIT MOUNT DRAWING (FLUSH TYPE)
NVX1000/3000-ID-007	MOUNT DRAWING FOR NAVTEX ANTENNA
NVX1000/3000-ID-008	NPT-100 PRINTER SIZE DRAWING

NXA200 ANTENNA

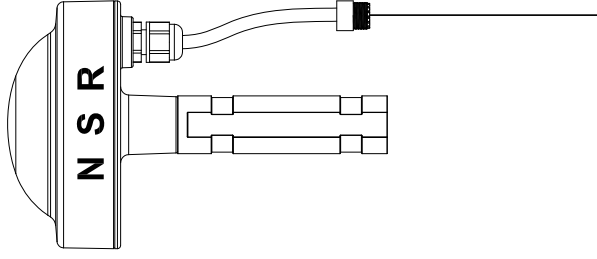

EXTERNAL PRINTER

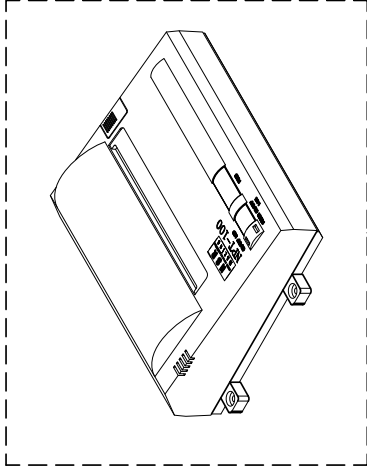

NAVTEX RECEIVER

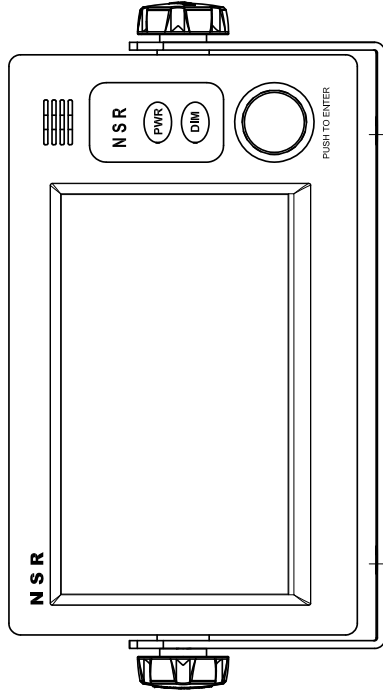

DC24V

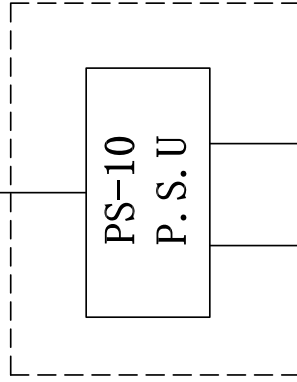

AC110V DC24V /220V

— Standard

- - - Optional

APPLICATION

NAVX-1000/NAVX-3000 NAVTEX SYSTEM DIAGRAM

DATE	NAVX-1000/NAVX-3000	NAVTEX RECEIVER	SIZE A4
APPROVAL	SCALE 1/1	1/1	VV
CHECKED			
DRAWING			
DWG. NO.	NAVX1000/3000-ID-001		



NEW SUNRISE CO., LTD.

NXA200 ANTENNA

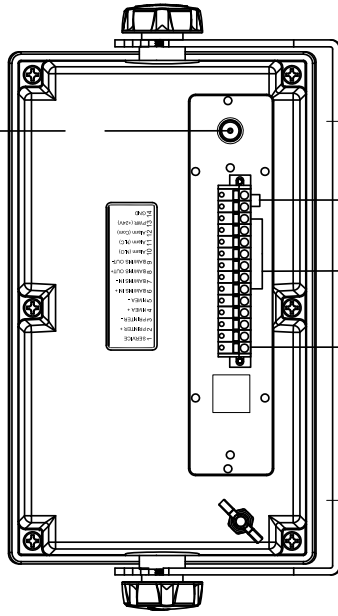
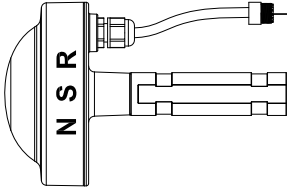

DC24V

NPT-100
PRINTER

BAM SYSTEM
/INS

PS-10
P.S.U

AC-110V DC24V
/220V

SHIP POWER

APPLICATION

NVX-1000/NVX-3000 CONNECTION DIAGRAM

DATE	NVX-1000/NVX-3000	NAVTEX RECEIVER	SIZE A4
APPROVAL			SCALE 1/1
CHECKED			DWG. NO. 002
DRAWING			
DWG. NO.	NVX1000/3000-IB-002		



NEW SUNRISE CO., LTD.

NXA200 ANTENNA

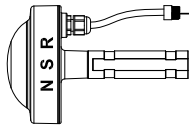

RG58/20M

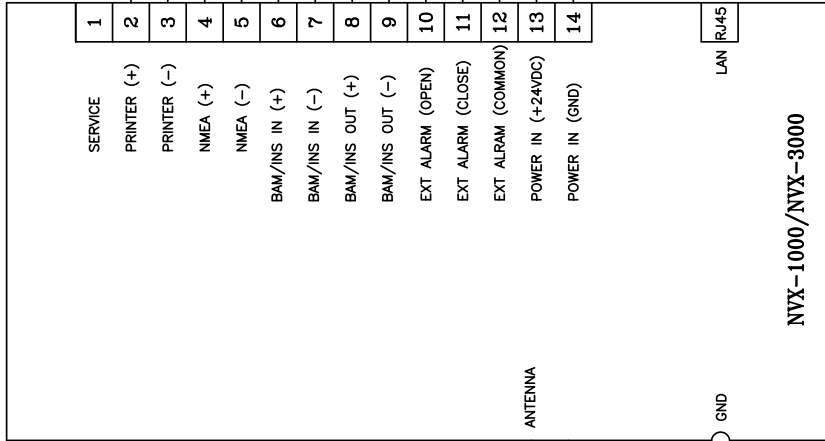
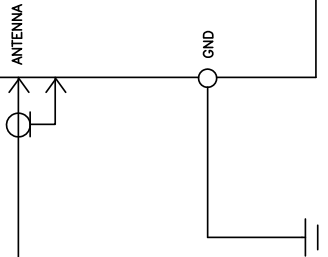

NVX-1000/NVX-3000

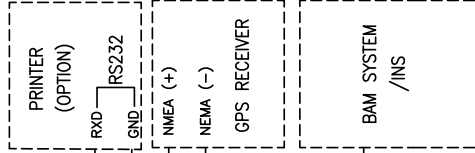

POWER SUPPLY 24VDC

7x0.4

2x0.4

APPLICATION

NVX-1000/NVX-3000 NAVTEX RECEIVER WIRING DIAGRAM

DATE	ITEM	SCALE	SIZE
APPROVAL	NVX-1000/NVX-3000 NAVTEX RECEIVER	1:1	A4
CHECKED	SCALE IN/S	1:1	V
DRAWING	DRAWING	1:1	V
DWG. NO.	NEW SURPRISE CO., LTD.	1:1	V

YARD SUPPLIED OR OPTIONAL

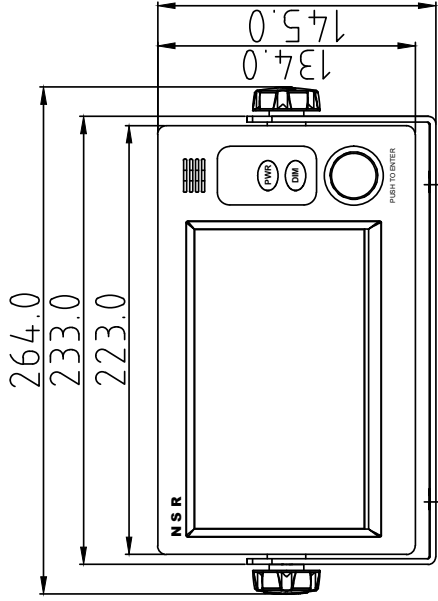

FRONT VIEW

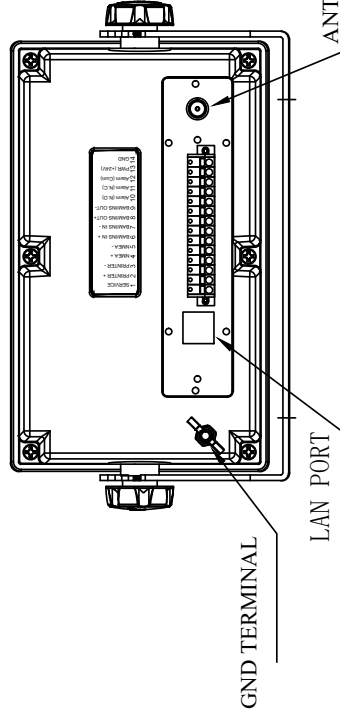
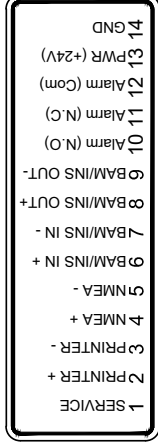

REAR VIEW

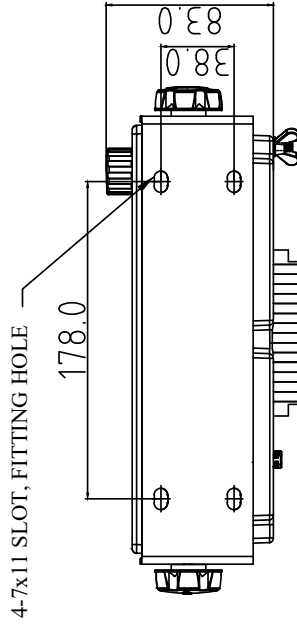

BOTTOM VIEW

APPLICATION			
NVX-1000/NVX-3000 MAIN UNIT DIMENSION DRAWING			
DATE	ITEM	NVX-1000/NVX-3000 NAVTEX RECEIVER	SIZE / A4
APPROVAL	SCALE	N/S	1:1
CHECKED			
DRAWING			
DWG. NO.	NVX1000/3000/03-004		
NSR		NEW SUNRISE CO., LTD.	

NOTE

1. FITTING HOLE SIZE = 165*38-7φ SLOT HOLE

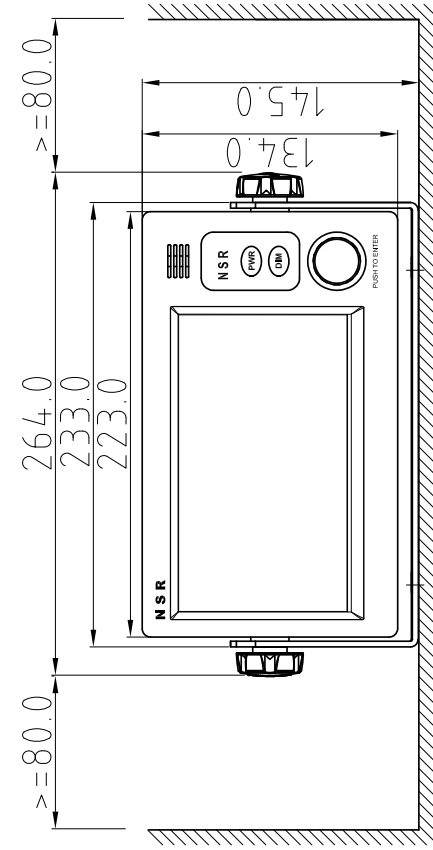

FRONT VIEW

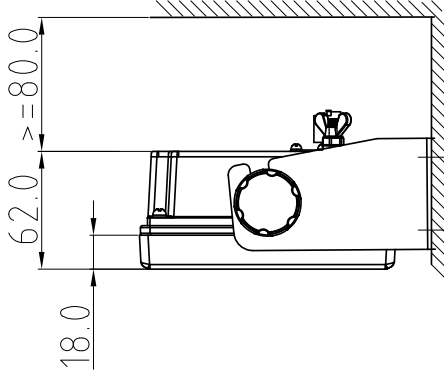

SIDE VIEW

NOTE

1. USE SELF-TAPPING SCREWS M5X20 FOR FIXING THE UNIT
2. 80MM IS MINIMUM SPACE FOR OPERATION AND CABLING.

APPLICATION

NVX-1000/NVX-3000 MAIN UNIT MOUNT DRAWING (TABLE TYPE)

DATE	ITEM	NVX-1000/NVX-3000	NAVTEX	RECEIVER	SIZE A4
APPROVAL	SCALE	1/1	1/1	1/1	1/1
CHECKED	DRAWING				
DWG. NO.		NSR		NEW SUNRISE CO., LTD.	

NO.	DATE	REVISION & DESCRIPTION	REVIEWED	DRAWN

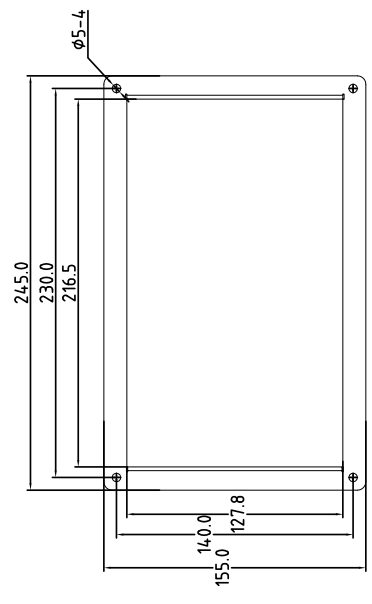
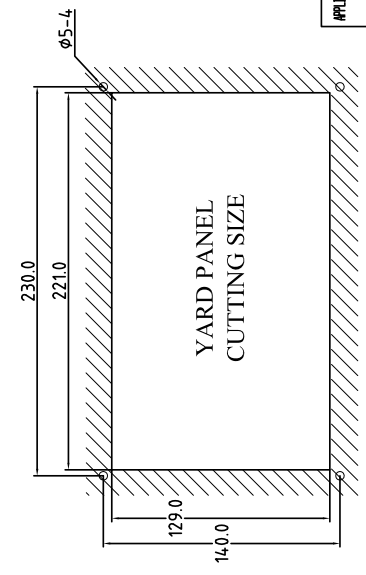
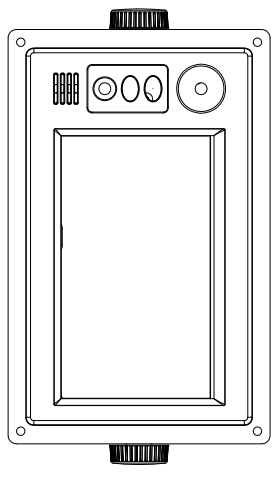
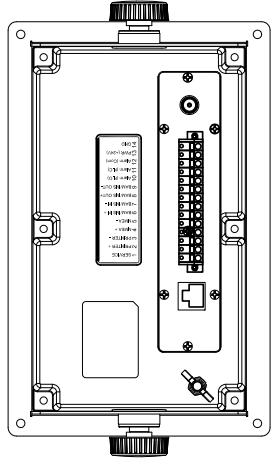
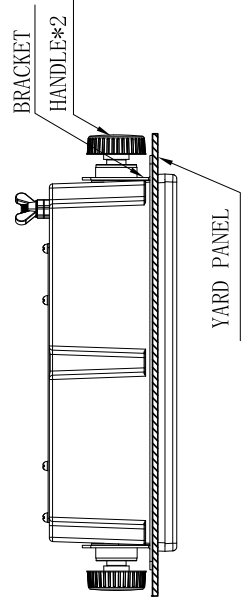
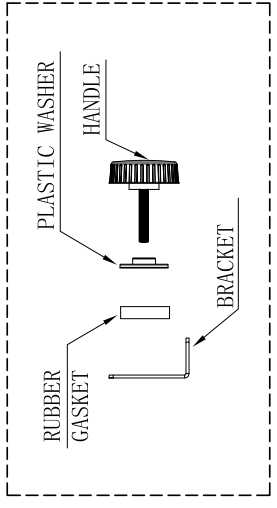
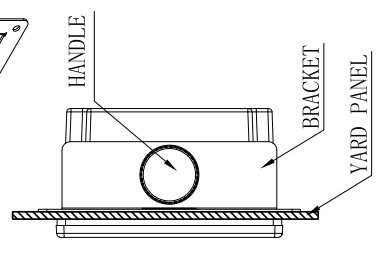
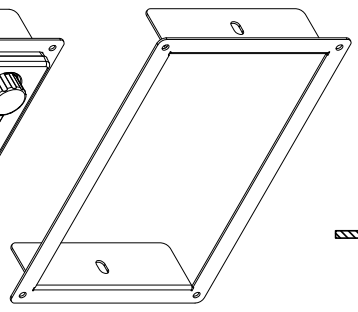
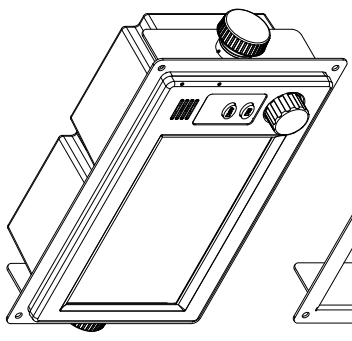

APPLICATION	NVX-1000/NVX-3000 MAIN UNIT MOUNT DRAWING (FLUSH TYPE)			
DATE	ITER	SCALE	UNIT	FIG. NO.
APPROVAL	DATE	SCALE	UNIT	FIG. NO.
CHECKED	DATE	SCALE	UNIT	FIG. NO.
DRAWING	DATE	SCALE	UNIT	FIG. NO.
FILE NO.	NEW SUNRISE CO., LTD.			

MOUNTING BRACKET SIZE

NXA200 ANTENNA

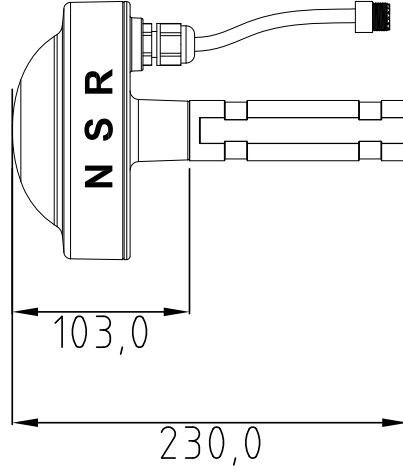
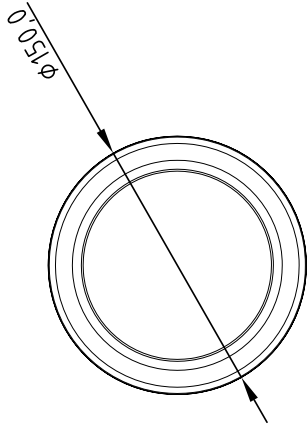
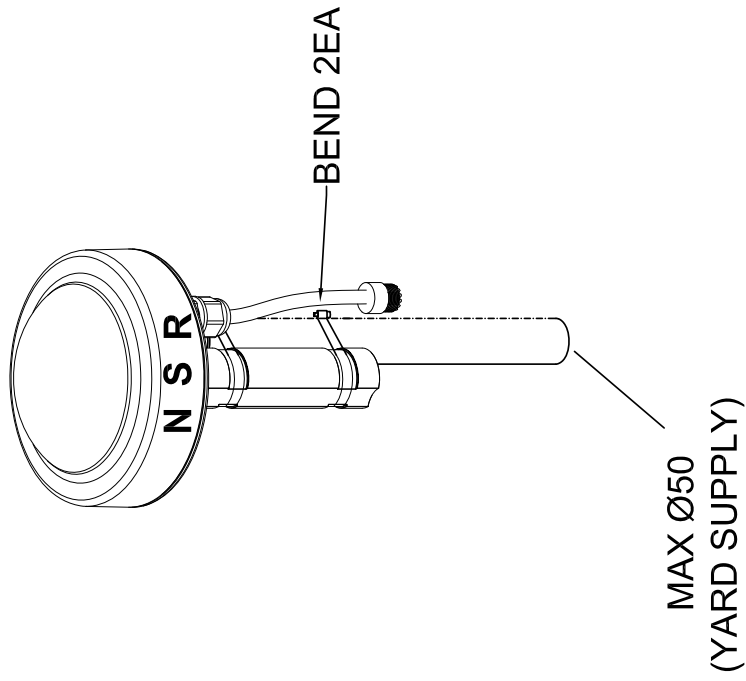

INSTALLATION

DIMENSION

APPLICATION

MOUNT DRAWING FOR NAVTEX ANTENNA

DATE	ITEM	NAV-1000/NAVC-3000	NAVTEX	RECEIVER	SIZE	A4
APPROVAL	SCALE	1/5	mm			
CHECKED						
DRAWING						
DWG. NO.		NAV1000/3000-ID-007				



NEW SUNRISE CO., LTD.

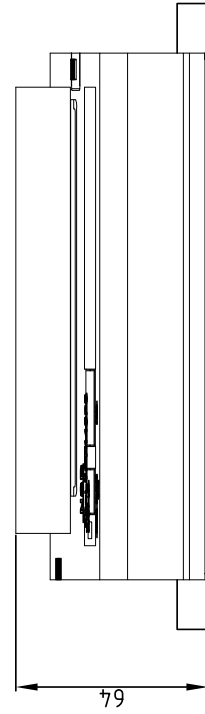
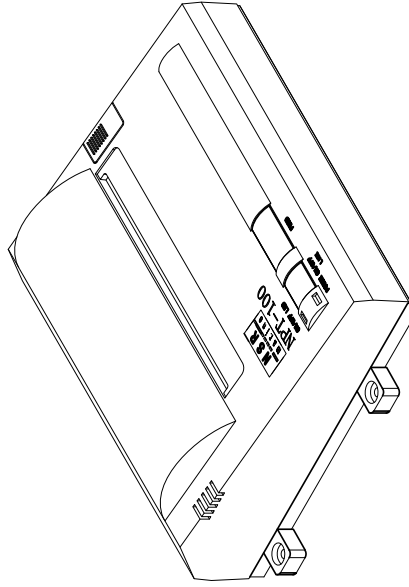
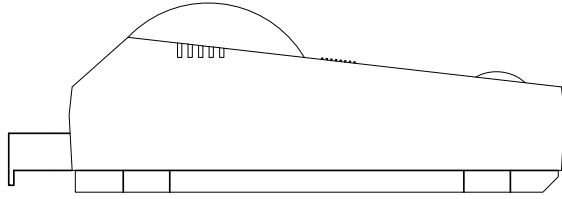
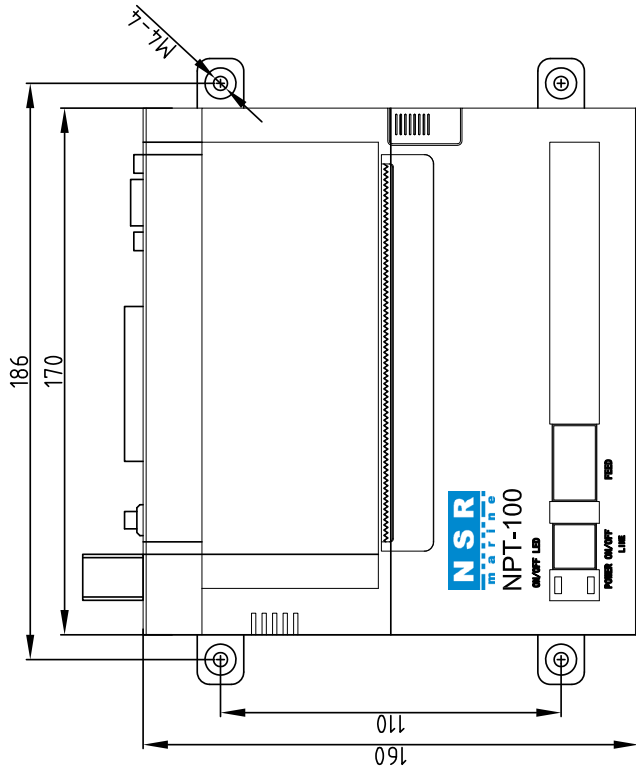

APPLICATION

NPT-100 PRINTER SIZE DRAWING

DATE	ITEM	NPT-100/AVC-3000	MAXTEX RECEIVER	SIZE	A4
APPROVAL	SCALE	1/1			V
CHECKED	DRAWING				VV
DWG. NO.		NPT1000/3000-ID-008			



NEW SUNRISE CO., LTD.

Copyright by NEW SUNRISE CO., LTD. (NSR)

www.nsrmarine.com

info@nsrmarine.com

December, 2025