



# User Manual

---

**AIS TESTER**

**NAT-200**

## MODIFY RECORD

No.	Modify by	Date	Paragraph	Version	Reason
1	Q/A	2015/06/20		01	First edition
2	Q/A	2020/05/15		02	Update the logo and pictures

## TABLE OF CONTENTS

Title	Item No	Page
Contents		
General Purpose	1	1-2
Main Characteristics	2	3
Complete Set	3	4
AIS TESTER operation and description	4	5
Operation procedures	5	6-23
Measurement of AIS, AIS-SART parameters	6	24-27
AIS TESTER's calibration	7	28
General operation environments	8	29
Safety precautions	9	30
Storage rules	10	31
<b>Appendix:</b>		
Appendix 1.		32

## 1. General purpose

- 1.1 The AIS tester is designed for checking of class A and class B - AIS mobile stations and AIS-SARTs. It is suitable for express checking and annual tests as well (according to the circular letter MSC.1/Circ.1252).
- 1.2 General view of the tester is represented on the fig.1-1



Figure 1-1. General view

- 1.3 AIS TESTER operates on frequencies of AIS channel 1, channel 2 and DSC – channel 70. It's designed in accordance with the ITU R M-1371-3, and IEC 61993-2 standards as technical equipment for AIS blocks and stations mounting accuracy testing on a vessel. Checking of the testable equipment is to carry out using the cable with included attenuator or by means of antenna through broadcast.

TESTER is controlled with the keyboard and graphic LCD-display with screen resolution 128\*64 dpi. Using the main menu one can perform full automatic checking. Testing results are shown on the display and saved in nonvolatile memory unit. AIS TESTER renders possible to save ten self-contained measuring sessions each of which easily can be transferred to a PC later using included software.

To use AIS TESTER there's no need to synchronize with GNSS (Global Navigation Satellite System) – AIS TESTER uses suitable slot synchronization technique which is not supposed to necessarily get GNSS timing signals. For general generated VDL and request information applied RATDMA ultra short waves access method of procedure.

One can check pilot plug and external sensor with the AIS TESTER because of using this equipment as terminal.

One doesn't need to possess some extra knowledge to operate the AIS TESTER – all you have to do is to make a thorough examination of this user manual. AIS TESTER can be programmed in any suggested conditions and can be simply upgraded.

- 1.4 AIS TESTER allows to:

- Measure AIS frequencies (on channels 1.2)
- Measure DSC channel frequency (channel 70)
- Measure or estimate the AIS transmitted power (on channels 1.2)
- Receive and decode the AIS messages
- Send the data to AIS stations
- Pass the DSC polling information (channel 70)
- Check AIS respond to so called "virtual vessel"
- Transmit and receive the DSC messages of different types for VHF stations

- 1.5 Under the terms of operation AIS TESTER is to use at a temperature range of + 5°C to + 45°C and relative humidity 95% depending on the LCD type.

- 1.6 The AIS TESTER is powered supply by four 1.5V AA batteries or external power supply unit with 4,2...6V and system load current not less than 450 mA, which is connected to the AIS TESTER via USB port (USB network adapter or PC USB port).

## 2. Main characteristics:

- 2.1 AIS operational frequencies are: channel 1 - 161.975 MHz ;  
channel 2 - 162.025 MHz.
- 2.2 DSC operational frequency channel 70 – 156.525 MHz.
- 2.3 Setting accuracy of output frequency – no less than  $\pm 1$ ppm.
- 2.4 Output power of AIS channel 1 and 2 and channel 70 DSC not less than (-7) dBm or 100 mW.
- 2.5 AIS modulation - FM-GMSK.
- 2.6 AIS channel band rate - 9600 Baud.
- 2.7 DSC channel band rate - 1200 Baud.
- 2.8 AIS TESTER provides carrier frequency measurement in range of 156-162MHz within the accuracy  $\pm 99$  Hz.
- 2.9 Input\Output resistance - - ( $50 \pm 1.5$ ) Ohm.

### NOTE:

**Input attenuator signal power level in continuous mode must be not more then 10 W.**

- 2.10 AIS TESTER allows saving of ten self-contained measuring sessions in nonvolatile memory unit. One measurement cycle time requires about 10 min.
- 2.11 AIS TESTER power supply requires four 1,5W AA batteries or external power supply of 4,2....6 W and power system load current no less than 500 mA which is connected to the AIS TESTER via USB port (USB network adapter or PC USB port).
- 2.12 AIS TESTER useful current from inner battery:
  - light-off stand-by mode – not above 190 mA
  - light-up stand-by mode - not above 250 mA
  - light-off measurement mode - not above 450 mA
- 2.13 Approximate continuous operation time using the battery – about 5 hours.
- 2.14 AIS TESTER displays internal battery voltage with accuracy  $\pm 5\%$ .

### 3. Complete set

3.1 Complete set of the AIS TESTER includes:

NO	Item	amt	Notification
1	AIS Tester	1	
2	Attenuator	1	
3	PC Cable (USB A – USB A) 1.5m	1	
4	PC Cable (DB9 - NMEA ) with open wires	1	
5	RF Cable TNC-TNC	1	
6	RF Cable BNC-BNC	1	
7	RF Connector BNC-UHF		
8	Antenna to make measurements through broadcast		
9	Technical Description and User Manual	1	
10	Package	1	
11	Software and software user's guide manual	1	optional; software can be downloaded at our website
12	Cable (DB9 - NMEA) with ready output for connection to pilot plug (Pilot plug cable)	1	optional

#### **4. AIS TESTER operation and description.**

- 4.1 The measurement of AIS parameters can be carried out by means of the cable and attenuator (with attenuation 46 dB) or by the outside antenna. The high-frequency cable is to be connected to the according input on the front panel (fig. 5-1).
- 4.2 The measurement can be carried out independently – in this case AIS TESTER supplies by means of internal battery units, or in steady-state conditions – by means of power-supply source.
- 4.3 The signal from the testable equipment goes to the duplexer by means of the attenuator (or antenna and broadcast), and after being filtrated it goes to the two separate receivers which get signals of different frequency. In this case the receiver of signal is a double-conversion superheterodyne. The first heterodyne has fixed frequency, but the second one has tunable frequency which helps to adjust to different frequency range. Both of this heterodynes has phase-locked-loop frequency control – it means that main frequency is the fixed frequency of temperature-compensated reference-frequency generator. First intermediate frequency channel is 6020 - 6040 kHz – it includes an intermediate-frequency amplifier, a log detector of receiving signal level, a ratio detector, that forms signal of phase rebounds – they means bipolar pulses that corresponds to the phase translation of phase-shift keyed signal input. This phase translation of phase-shift keyed signal input is needed to decode information and phase deviation calculation in main controller.
- 4.4 The signal receiver is a superheterodyne with a single frequency changing and a heterodyne that included in phase-locked-loop frequency control circuit. In channel are included: heterodyne, mixer, intermediate-frequency amplifier, and a log detector of receiving signal level. This detector detects amplitude modulation signal and reports a sweep signal to a main controller with the amplitude which is proportional to the receiving signal level.
- 4.5 All the changes are performed by the main controller which in it's turn controlled by the frequency of high-stable reference-frequency generator. Main controller plug-in besides AIS signal processing maintains the indicator, keyboard and acoustic controller work. Besides, main controller energize only the necessary units – it saves energy greatly – and also it imports data to the PC using interface level transducer RS-232.
- 4.6 Reference supply source is used to improve measurement accuracy received signal level.

## 5 Operation

### 5.1 Operation and connection control.

- 5.1.1 On the front panel of the AIS TESTER are LCD indicator with the screen resolution 128\*64 and keyboard. (Fig. 5-1).
- 5.1.2 The AIS TESTER can be turned on by pressing and holding the **ON** button for one second, and turned be off just by simple pressing of the same (Fig. 5-1).
- 5.1.3 Navigation buttons ←, →, ↓, ↑, **ESC**, **ENT** will help to choose menu options and to execute selected operations, and also for confirmation/cancelling of the selected operation. (Fig. 5-1).
- 5.1.4 **F1** и **F2 buttons** in main menu will turn on and turn off LCD lighting accordingly. Sometimes this buttons control other optional functions – such cases will be described below.



Figure 5-1. AIS TESTER outputs

- 5.1.5 **MENU** button helps to get quick entrance or return to the main menu.

There is HF input for the antenna or attenuator connection on the top of the AIS TESTER's case. On the bottom panel of the device the additional slot for PC or power supply adapter connection and DB-9 output for NMEA cable connection are placed (Fig. 5-1).

## 5.2 Turning ON/OFF

Turning on of the device is carried out by pressing and holding **ON** button till sound signal and the moment when main logo screen image will appear on the display (0.5 - 1 second):

Then release **ON** button.

Press and hold **ON** button for 2 seconds to turn the device OFF.

## 5.3 AIS TESTER's main menu.

By pressing **MENU** button or **ENT** button on logo screen one can reach the main menu of the AIS TESTER. By using buttons ↑ (up) and ↓ (down) you can execute vertical movement.

Using the **ENT** button one can enter the main menu subitems. To exit the menu sections use the **ESC** button.

**Main menu has five items:**

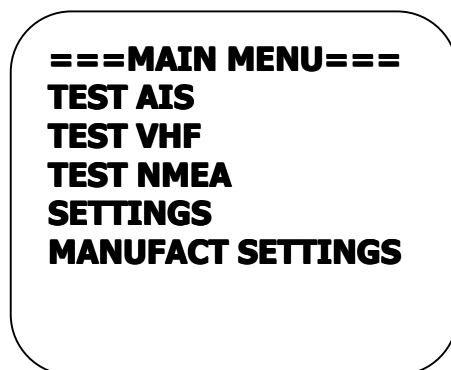

**TEST AIS** – AIS equipment testing;  
**TEST VHF** – VHF stations with DSC testing;  
**TEST NMEA** – reception and displaying on LCD of NMEA messages;  
**SETTINGS** - AIS TESTER parameters settings;  
**MANUFACT SETTINGS** - manufacturer technical menu;

Each menu item has its own subsections. User moves among the subsections using the same buttons as for the moving in main menu.

Use the **MENU** or **ESC** button to go back to main menu.

### 5.3.1 TEST AIS

**TEST AIS Menu** contains the following items:

**==== TEST AIS====**  
**Test AIS class A**  
**Test AIS class B**  
**Test AIS-SART**  
**Ship Emulation**  
**AIS monitor**

**TEST AIS Class A** – to test the AIS station class A;  
**TEST AIS Class B** – to test the AIS station class B;  
**TEST AIS-SART** – to the AIS-SART;  
**Ship Emulation** – “virtual ship” emulation;  
**AIS monitor** – continuous reception by AIS TESTER of all data sent by AIS station in VHF AIS channel and displaying it on LCD.

#### 5.3.1.1 TEST AIS Class A

The **TEST AIS Class A** has following subitems:

**=== Test AIS-A ===**  
**AUTO TEST MODE**  
  
**Interrogation Msg 3**  
**Interrogation Msg 5**  
**Polling DSC**

**AUTO TEST MODE** – the automatic mode for complex test of AIS station class A;

**Interrogate Msg 3** – request for message 3 and waiting for respond;

**Interrogate Msg 5** – request for message 5 and waiting for respond;

**Polling DSC** – request for data in channel 70(DSC) and waiting for respond.

**AUTO TEST MODE** – the automatic mode for complex test of AIS station class A.

**== MMSI FILTER ==**  
  
**MMSI : 00000000**  
**No filter**  
  
**F1 – Clear filter**  
**Start - ENTER**

It is recommended to enter the MMSI number of the AIS station before starting tests. This allows ignoring the messages from other AIS stations. It will help to perform tests by means of antenna through broadcast in port area.

Use LEFT/RIGHT buttons to select the digit and UP/DOWN buttons to change it. Press ENTER button after the MMSI code was entered.

The 00000000 MMSI code means the filter is not applied, so the device will receive all messages from any AIS station.

Note that not zero values can be displayed here. The AIS TESTER automatically offers to use the MMSI code encoded from last received message. So, if the MMSI code of AIS Station is unknown or you'd like to avoid the manual input of the code **use AIS MONITOR** mode and receive at least 1 message from the AIS Station to be tested. Return to **AUTOTEST MODE** to perform all tests.

Also if you perform tests by means of attenuator don't apply the filter set zero MMSI code by pressing of F1 button.

```

===AUTO AIS-A===
RxA ID 1 20199999
dF +142 Hz
RSSI 40.94 dBm
Slot:411
A B 1u 5 DSC
33°29.24 E Save-
F2z44°35.33 N Prof:
    
```

*The following information will be received, measured or decoded and displayed on LCD in this mode:*

**Rx X, where X - (A or B)** – the AIS channel of the received message;  
**ID X, where X – (1 to 26)** – the message number under M.1371-4;  
**201999999** (this is example!) – MMSI of AIS station  
**dF +142 Hz** – channel nominal frequency deviation of AIS station transmitter;  
**RSSI 40.94 dBm** – AIS station transmitter power level in dBm;

**Slot: 411** – the frame slot number of sent message;  
 - Status Bar, 4-cell complete state.

The complete state of the status bar confirms that the AIS TESTER collect all necessary information about tested AIS station and ready to save the data to memory.

The AIS TESTER requires to receive Message 1 (Msg1) or Message 3 (Msg3) in any channel, receive any message in A or B channels, receive Message5 (Msg5) in any channel to get all necessary information. The AIS TESTER will allow to save the date only when all information is received.

### **The maximum measurement cycle time is 15 minutes.**

There are additional information about received data is viewed near the status bar:

**A** – received message in channel A,

**B** – received message in channel B,

**1** – received Message 1 or Message 3, sign **u** confirms that UTC info is received.

**5** – received message 5.

**DSC** – received respond in DSC channel (In accordance with M.1371-3 the respond to DSC request is not regulated as it was in M.1371-1, so AIS station may not respond to DSC request)

Usually it is enough to receive the message 1(Msg1) in channel A or B, message 5(Msg5) in any channel and measure the power level of received signal. At the bottom left corner the received and decoded coordinates are displayed.

After the status bar is completed the following note will be displayed in bottom right corner:

**Save-F2** – allows saving all received data by pressing F2, and the **Prof: X**, where X = 1 to 10, - profile number where all data will be saved. The number is increased automatically by circle, and after Mes10 – the Mes1 will be used, new data will erase the old one automatically, so no any special function to free the memory is required.

In this mode all data will be collected automatically, the AIS TESTER receives the Message 1(Msg1), measures the power level and frequency deviation, sends the request for Message 5(Msg5), and after reception of Message 5, the AIS TESTER sends the “virtual ship” message to AIS station (ship emulation located 0,1 mile on East from AIS station). The MMSI of virtual ship is 201999998.

----- **TIMEOUT** -----  
**RxA complete**  
**RxB complete**  
**Msg1 complete**  
**Msg5 not received**

**Save-F2**  
**Exit - ESC**

The measurement cycle can be interrupted by pressing F1 button. In this case the AIS TESTER offers to save incomplete data.

When the F1 is pressed the TIMEOUT menu will be viewed with list of received and not received data.

The AIS TESTER will be switched to this menu automatically if the required data will not be received in 15 minutes period.

**Interrogate Msg3 Menu** – allows to send the request with message 3 (Msg3).

=== **Message 3** ===  
**Channel A**  
**Channel B**

**To: 272999999**

The menu offers to select the channel to send the request as well to receive the message 3.

Select the channel by means of **Up** and **Down** key and press **ENT**.

The AIS station MMSI code of target station is displayed lower. It is possible to change the MSSI code manually. Use the **UP** and **DOWN** keys and select line "TO:". Then use the **LEFT** and **RIGHT** keys to switch between the MMSI code numbers and use **F1** and **F2** to change them.

==**REQUEST 3 ChA**==  
**Rx\* ID \* \*\*\*\*\***  
**dF \*\*\*\*\* Hz**  
**RSSI \*\*\*\*\* dBm**  
**Slot: \*\*\*\*\***

**Wait for Request**

After the channel is selected press the ENT button. The following menu will be displayed and confirmed by sound signal. After sound termination (approximate 4 seconds) the request will be sent to address of tested station. Then AIS TESTER goes to waiting mode for Message 3. All other messages will be ignored.

**The received Message 3 will be displayed in following view:**

==**REQUEST 3 ChA**==  
**RxA ID 3 272999999**  
**dF -291 Hz**  
**RSSI 41.2 dBm**  
**Slot: 160**

**33°29.24 E**  
**44°35.33 N**

**Rx A** – the AIS channel where the message is received;  
**ID 3** – the number of Message in accordance with M.1371-3;  
**272999999** (this is example!) – the tested AIS station MMSI code;  
**dF - 291 Hz** – channel nominal frequency deviation of AIS station transmitter;  
**RSSI 41.2 dBm** – AIS station transmitter power level in dBm;  
**33°29.24 E**  
**44°35.33 N** – the AIS station coordinates.

The message 3 as the respond to request should be transferred and received in 60 seconds after the sound was terminated. If the AIS station has reception indicator (usually it is RX Led), after the sound was terminated this LED should confirm the reception of the request.

**Interrogate Msg5** menu – allows to send the request with message 5(Msg5).

**=== Message 5 ===**  
**Channel A**  
**Channel B**

**To: 272999999**

The menu offers to select the channel to send the request as well to receive the message 5.

Select the channel by means of **Up** and **Down** key and press **ENT**.

The AIS station MMSI code of target station is displayed lower. It is possible to change the MSSI code manually. Use the **UP** and **DOWN** keys and select line "TO:". Then use the **LEFT** and **RIGHT** keys to switch between the MMSI code numbers and use **F1** and **F2** to change them.

**==REQUEST 5 ChA==**  
**Rx\* ID \* \*\*\*\*\***  
**dF \*\*\*\*\* Hz**  
**RSSI \*\*\*\*\* dBm**  
**Slot: \*\*\*\***

**Wait for Request**

After the channel is selected press the ENT button. The following menu will be displayed and confirmed by sound signal. After sound termination (approximate 4 seconds) the request will be sent to address of tested station. Then AIS TESTER goes to waiting mode for Message 5. All other messages will be ignored.

**The received Message 5 will be displayed in following view:**

**==REQUEST 5 ChA==**  
**RxA ID 5 272999999**  
**dF -291 Hz**  
**RSSI 41.2 dBm**  
**Slot: 160**  
**Tornado**

**Rx A** – the AIS channel where the message is received;

**ID 5** – the number of Message in accordance with M.1371-3;

**272999999** (this is example!) – the tested AIS station MMSI code;

**dF - 291 Hz** – channel nominal frequency deviation of AIS station transmitter;

**RSSI 41.2 dBm** – AIS station transmitter power level in dBm;

**Tornado** – vessel name where the AIS station is installed.

The message 5 as the respond to request should be transferred and received in 60 seconds after the sound was terminated. If the AIS station has reception indicator (usually it is RX Led), after the sound was terminated this LED should confirm the reception of the request.

## Polling DSC Menu

This menu item allows sending the request in DSC channel for vessel name programmed in AIS station and receiving the respond.

**Note: In accordance with ITU-R M.1371-3 (as opposed to M.1371-2), the AIS station respond in DSC channel is not exactly regulated.**

The following data is displayed in this menu:

**== Polling DSC ==**

**To: 272999999**  
**From: 201999998**

**Start - Enter**

**To: 272999999** – requested station MMSI;  
**From: 201999998** – AIS TESTER’s MMSI.

The requested station MMSI is determined by message received in **AUTO TEST MODE**. If the MMSI code is correct press **ENTER** to send the request. The sound signal confirms the request was sent in DSC channel. The AIS TESTER goes to waiting mode for respond in DSC channel. The AIS TESTER will wait for 20 seconds for AIS station respond.

It is possible to change the MSSI code manually. Use the **UP** and **DOWN** keys and select line “TO:”. Then use the **LEFT** and **RIGHT** keys to switch between the MMSI code numbers and use **F1** and **F2** to change them.

After the respond message is received the following information will be displayed:

**== RECEIVED DSC ==**

**FORMAT: INDIVIDUAL**  
**CATEGORY: INFORM.**  
**FROM: 272999999**  
**NAME: TORNADO**

**RSSI: 41.2 dBm**  
**FCH70: 156525003Hz**

**FORMAT: INDIVIDUAL** – format of received DSC message;  
**CATEGORY: INFORM.** (Information) – category of received DSC message;  
**FROM: 272999999** – AIS station MMSI;  
**NAME: TORNADO** – vessel name where the AIS station is installed;  
**RSSI: 41.2 dBm** – power level of received signal in dBm;  
**FCH70** – frequency on DSC channel.

The request sent to AIS station contains the following DSC message in accordance with ITU-R M.825-3 :

<b>120, 120</b>	Format specifier – Individual call
<b>27,30,00,00,00</b>	MMSI requested station (for example)
<b>103</b>	Category – Information
<b>20,19,99,99,90</b>	Self-identification = AIS TESTER’s MMSI no.
<b>111</b>	Message – <b>Report ship’s name/identification</b>
<b>117</b>	End of sequence – Ack.RQ
<b>xxx</b>	ECC – modulus-2 checsum
<b>117,117</b>	End of sequence – Ack.RQ.

### 5.3.1.2 Test AIS Class B

The **TEST AIS Class A** has following subitems:

**=== Test AIS-B ===  
AUTO TEST MODE**

**Interrogation Msg 18  
Interrogation Msg 24**

**AUTO TEST MODE** – the automatic mode for complex test of AIS station class B;

**Interrogate Msg 18** – request for message 18 and waiting for respond;

**Interrogate Msg 24** – request for message 24 and waiting for respond;

**AUTO TEST MODE** – the automatic mode for complex test of AIS station class B.

**== MMSI FILTER ==**

**MMSI : 00000000  
No filter**

**F1 – Clear filter  
Start - ENTER**

It is recommended to enter the MMSI number of the AIS station before starting tests. This allows ignoring the messages from other AIS stations. It will help to perform tests by means of antenna through broadcast in port area. Use LEFT/RIGHT buttons to select the digit and UP/DOWN buttons to change it. Press ENTER button after the MMSI code was entered.

The 000000000 MMSI code means the filter is not applied, so the device will receive all messages from any AIS station.

Note that not zero values can be displayed here. The AIS TESTER automatically offers to use the MMSI code encoded from last received message. So, if the MMSI code of AIS Station is unknown or you'd like to avoid the manual input of the code **use AIS MONITOR** mode and receive at least 1 message from the AIS Station to be tested. Return to **AUTOTEST MODE** to perform all tests.

Also if you perform tests by means of attenuator don't apply the filter set zero MMSI code by pressing of **F1** button.

The following information will be received, measured or decoded and displayed on LCD in this mode:

**===AUTO AIS-B===  
RxA ID 1 201999999  
dF +142 Hz  
RSSI 32.8 dBm  
Slot:411  
A B 24a 24b  
33°29.24 E Save-F2  
44°35.33 N Prof: 8**

**Rx X, where X - (A or B)** – the AIS channel of the received message;

**ID X, where X – (1 to 26)** – the message number under M.1371-3;

**201999999** (this is example!) – MMSI of AIS station

**dF +142 Hz** – channel nominal frequency deviation of AIS station transmitter;

**RSSI 40.94 dBm** – AIS station transmitter power level in dBm;

**Slot: 411** – the frame slot number of sent message;  
- Status Bar, 4-cell complete state.

The complete state of the status bar confirms that the AIS TESTER collect all necessary information about tested AIS station and ready to save the data to memory.

The AIS TESTER requires to receive Message 18 (Msg18) in any channel, receive any message in A or B channels, receive Message24a (Msg24b) and message 24b (Msg24b) in any channel to get all necessary information. The AIS TESTER will allow to save the date only when all information is received.

**The maximum measurement cycle time is 15 minutes.**

There are additional information about received data is viewed near the status bar:

- A** – received message in channel A,
- B** – received message in channel B,
- 24a** – received Message 24a,
- 24b** – received message 24b.

After the status bar is completed the following note will be displayed in bottom right corner:  
**Save-F2** – allows saving all received data by pressing F2, and the **Prof: X**, where X = 1 to 10, - profile number where all data will be saved. The number is increased automatically by circle, and after Mes10 – the Mes1 will be used, new data will erase the old one automatically, so no any special function to free the memory is required.

In this mode all data will be collected automatically, the AIS TESTER receives the Message 18(Msg18), measures the power level and frequency deviation, sends the request for Message 24(Msg24), and after reception of Message 24, the AIS TESTER sends the “virtual ship” message to AIS station (ship emulation located 0,1 mile on East from AIS station). The MMSI of virtual ship is 201999998.

----- **TIMEOUT** -----  
**RxA complete**  
**RxB complete**  
**Msg18 complete**  
**Msg24 not received**  
  
**Save-F2**  
**Exit - ESC**

The measurement cycle can be interrupted by pressing F1 button. In this case the AIS TESTER offers to save incomplete data.

When the F1 is pressed the TIMEOUT menu will be viewed with list of received and not received data.

The AIS TESTER will be switched to this menu automatically if the required data will not be received in 15 minutes period.

**Interrogate Msg18 Menu** – allows sending the request with message 18(Msg18).

=== **Message 18** ===  
**Channel A**  
**Channel B**  
  
**To: 272999999**

The menu offers to select the channel to send the request as well to receive the message 18.

Select the channel by means of **Up** and **Down** key and press **ENT**.

The AIS station MMSI code of target station is displayed lower. It is possible to change the MSSSI code manually. Use the **UP** and **DOWN** keys and select line “TO:”. Then use the **LEFT** and **RIGHT** keys to switch between the MMSI code numbers and use **F1** and **F2** to change them.

```

==REQUEST 18ChA==
Rx* ID * *****
dF **** Hz
RSSI **** dBm
Slot: ****
    
```

**Wait for Request**

After the channel is selected press the ENT button. The following menu will be displayed and confirmed by sound signal. After sound termination (approximate 4 seconds) the request will be sent to address of tested station. Then AIS TESTER goes to waiting mode only for Message 18. All other messages will be ignored.

**The received Message 18 will be displayed in following view:**

```

==REQUEST 18ChA==
RxA ID18 272999999
dF -291 Hz
RSSI 32.8 dBm
Slot: 160
!
33°29.24 E
44°35.33 N
    
```

**Rx A** – the AIS channel where the message is received;  
**ID 18** – the number of Message in accordance with M.1371-3;  
**272999999** (this is example!) – tested AIS station MMSI code;  
**dF - 291 Hz** – channel nominal frequency deviation of AIS station transmitter;  
**RSSI 32.8 dBm** – AIS station transmitter power level in dBm;  
**33°29.24 E**  
**44°35.33 N** – the AIS station coordinates.

The message 18 as the respond to request should be transferred and received in 60 seconds after the sound was terminated. If the AIS station has reception indicator (usually it is RX Led), after the sound was terminated this LED should confirm the reception of the request.

**Interrogate Msg24** menu – allows sending the request with message 24(Msg24).

```

=== Message 24===
Channel A
Channel B
    
```

**To: 272999999**

The menu offers to select the channel to send the request as well to receive the message 24. Select the channel by means of **Up** and **Down** key and press **ENT**.

The AIS station MMSI code of target station is displayed lower. It is possible to change the MSSI code manually. Use the **UP** and **DOWN** keys and select line "TO:". Then use the **LEFT** and **RIGHT** keys to switch between the MMSI code numbers and use **F1** and **F2** to change them.

```

==REQUEST 24ChA==
Rx* ID * *****
dF **** Hz
RSSI **** dBm
Slot: ****
    
```

**Wait for Request**

After the channel is selected press the ENT button. The following menu will be displayed and confirmed by sound beep. After sound termination (approximate 4 seconds) the request will be sent to address of tested station. Then AIS TESTER goes to waiting mode for Message 24. All other messages will be ignored.

**The received Message 24 will be displayed in following view:**

```

==REQUEST 24ChA==
RxA ID 24 272999999
dF -291 Hz
RSSI 32.8 dBm
Slot: 160 Sync OK!
PELIKAN
    
```

**Rx A** – the AIS channel where the message is received;  
**ID 24** – the number of Message in accordance with M.1371-3;  
**272999999** (this is example!) – tested AIS station MMSI code;  
**dF - 291 Hz** – channel nominal frequency deviation of AIS station transmitter;  
**RSSI 32.8 dBm** – AIS station transmitter power level in dBm;  
**PELIKAN** – vessel name where the AIS station is installed.

The message 24 as the respond to request should be transferred and received in 60 seconds after the sound was terminated. If the AIS station has reception indicator (usually it is RX Led), after the sound was terminated this LED should confirm the reception of the request.

### 5.3.1.3 Test AIS-SART

**==USER ID FILTER==**

**MMSI : 00000000**  
**No filter**

**F1 – Clear filter**  
**Start - ENTER**

It is recommended to enter the USER ID number of the AIS-SART before starting tests. This allows ignoring the messages from other AIS stations. It will help to perform tests by means of antenna through broadcast in port area. Use LEFT/RIGHT buttons to select the digit and UP/DOWN buttons to change it. Press ENTER button after the USER ID code was entered.

The 00000000 MMSI code means the filter is not applied, so the device will receive all messages from any AIS station.

Note that not zero values can be displayed here. The AIS TESTER automatically offers to use the MMSI code encoded from last received message. So, if the MMSI code of AIS Station is unknown or you'd like to avoid the manual input of the code **use AIS MONITOR** mode and receive at least 1 message from the AIS Station to be tested. Return to **AUTOTEST MODE** to perform all tests.

Also if you perform tests by means of attenuator don't apply the filter set zero MMSI code by pressing of **F1** button.

The following data will be displayed in this mode:

```

=== AIS SART ===
RxA ID 1 97000001
dF +142 Hz
RSSI 32.8 dBm
Slot:411
A4B4 1:6
14:2
33°29.24 E Save-F2
44°35.33 N Prof: 8
    
```

**Rx X**, where X (A or B) – AIS channel in which the message was received;

**ID X**, where X (1 or 14) – the message number in accordance with IEC 61097-14;

**97000001** (example) – USER ID of AIS SART encoded in received message;

**dF +142 Hz** – channel nominal frequency deviation of AIS station transmitter;

**RSSI 32.8 dBm** – AIS station transmitter power level in dBm;

**Slot : 411** – the slot number in received message frame;  
- Status Bar, 4-cell complete state.

The complete state of the status bar confirms that the AIS TESTER collect all necessary information about tested AIS-SART and ready to save the data to memory.

The AIS TESTER requires to receive 8 messages where 6 messages are MSG1 and 2 messages MSG14 in any channel, and also confirm reception of any message in A and B channels to get all necessary information. The AIS TESTER will allow to save the date only when all information is received.

There are additional information about received data is viewed near the status bar:

**A4** – number of received message in channel A,

**B4** – number of received message in channel B,

**1:6** – number of received Message 1,

**14:2** – number of received Message 14.

After the status bar is completed the information about sync slot will be removed and Msg14 – “SART TEST” or “SART ACTIVE” note will be displayed.

The coordinates received from AIS-SART are displayed at the left bottom corner. If the AIS-SART is tested in closed room it can't determine its coordinates. In this case the AIS-SART transmits the default coordinates that will be confirmed by corresponding display note.

After the status bar is completed the following note will be displayed in bottom right corner:

**Save-F2** – allows saving all received data by pressing F2, and the **Prof: X**, where X = 1 to 10, - profile number where all data will be saved. The number is increased automatically by circle, and after Mes10 – the Mes1 will be used, new data will erase the old one automatically, so no any special function to free the memory is required.

----- **TIMEOUT** -----  
**RxA complete**  
**RxB complete**  
**Msg1 complete**  
**Msg14 not received**

**Save-F2**  
**Exit - ESC**

The AIS-SART measurements can be interrupted by F1 button press.

The AIS TESTER will offer to save the incompletely measured data.

When F1 is being pressed the following list will with received/not received data status be displayed.

The AIS TESTER will be automatically set to this mode after 15 minutes operation.

### 5.3.1.4 Ship Emulation

Entering the menu user should select the channel for testing (A or B).

**= Ship Emulation =**  
**Channel A**  
**Channel B**

**Virtual ship emulation procedure is performed as follows:**

The Message 1 with the AIS TESTER's MMSI code and increased on about 0.1 mile last received message coordinates will be sent to ship address specified in **AUTO TEST MODE** or **AIS MONITOR** (by Messages 1 or 5).

As a result the virtual ship with a little different coordinates should appear on tested AIS station LCD.

**= Ship Emulation =**  
  
**Channel A**  
**From: 20199998**

**Start - ENT**

After pressing the **ENTER** button a message **"Wait !"** will appear on the screen. The message transmission will be performed after the sound signal.

**NOTE: It is important to receive at least one message in AUTO TEST MODE or AIS MONITOR mode and only then ones should perform the ship emulation. It is required synchronization of AIS TESTER and AIS station and virtual ship coordinates definition.**

### 5.3.1.5 AIS MONITOR

The AIS TESTER receives in continuous mode all AIS station messages and displays them on LCD (example):

**===AIS Monitor===**  
**RxA ID 1 201999999**  
**dF +142 Hz**  
**RSSI 40.94 dBm**  
**Slot:411**  
  
**33°29.24 E**  
**44°35.33 N**

**Rx A** – the AIS channel where the current message is received;  
**ID X** – the number of Message in accordance with M.1371-3;  
**272999999** (this is example!) – tested AIS station MMSI code;  
**dF + 142 Hz** – channel nominal frequency deviation of AIS station transmitter;  
**RSSI 40.94 dBm** – AIS station transmitter power level in dBm;  
**Slot: 411** – the frame slot number of sent message;  
**33°29.24 E 44°35.33 N** – the AIS station coordinates.

### 5.3.2 TEST VHF

This menu allows sending the different format DSC messages to VHF stations with DSC as well as receiving any DSC message from VHF stations.

**====TEST VHF====**  
**Send DSC**  
**Receive DSC**

So, the menu contains two submenus:

- **SEND DSC**
- **RECEIVE DSC**

#### 5.3.2.1 SEND DSC

Choose the SEND DSC menu item to send the DSC message to VHF station.

**====Send DSC====**  
**TEST**  
**TRAFFIC**  
**DISTRESS**  
**INFORMATION**

Press ENT key and then select the category of DSC message to be sent.

Press ENT again.

**====TRAFFIC====**

**To: 00000000  
From: 20199998**

**Start - ENTER**

It is necessary to determine the VHF station MMSI code on the next step.

Use the **LEFT, RIGHT** key to navigate between numbers and **UP, DOWN** to change them. Specify the VHF MMSI code where the message will be sent and press **ENT**. Sound signal will confirm the transmission.

### 5.3.2.2 Receive DSC

This menu item allows receiving the DSC messages from VHF station. Press ENT to start reception. The note "WAIT!" will confirm the AIS TESTER goes to waiting mode.

**== RECEIVED DSC ==  
FORMAT: INDIVIDUAL  
CATEGORY: INFORM.  
FROM: 27299999  
TO: 27265400  
CRC: OK**

After the message is received the AIS TESTER will display it on LCD.

### 5.3.3 TEST NMEA

This menu item allows receiving all information incoming to presentation ports of AIS station, such as pilot plug. If it is necessary to receive the information from pilot plug select the 38400 baud rate, or select the 4800 baud rate to check the sensors.

The AIS TESTER allows connecting outputs with RS 422 or RS 232. The protocol is NMEA 0183(ITU 61 162-1).

### 5.3.4 VIEW PROFILES

**This menu item allows viewing all stored data. The measurement data is stored in 10 profiles (memory cells). Use LEFT, RIGHT key to navigate between profiles.**

Each profile contains the following data:

**Pr:2 15:40 19/10/2010  
MMSI: 272658000  
MARIA  
A:40.2dBm dF+165 Hz  
B:40.2dBm dF +92 Hz  
Long: 33°29.24 E  
Lat : 44°35.33 N  
← →**

**Pr:2** – profile number;  
**15:40** – measurement time;  
**19/10/2010** – measurement date;  
**MMSI: 272658000** – tested station MMSI;  
**MARIA** – vessel name programmed in AIS station;  
**A:40.2dBm dF+165 Hz** – power level and frequency deviation in channel A;  
**B:40.2dBm dF +92 Hz** – power level and frequency deviation in channel B;  
**Long: 33°29.24 E**  
**Lat : 44°35.33 N** – AIS station coordinates.

### 5.3.5 SETTINGS

This menu item allows adjusting all AIS TESTER settings.

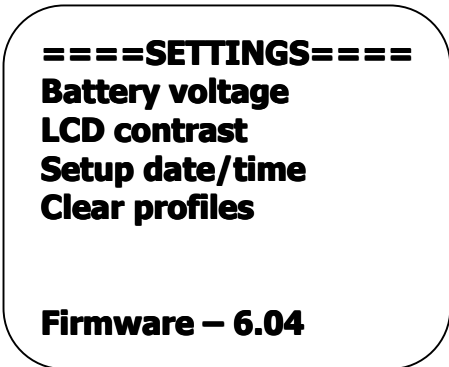

**So, the menu contains two submenus:**

- Battery voltage** – AIS TESTER batteries voltage indication;
- LCD contrast** – LCD contract meaning adjustment;
- Setup date/time** – date/time, date format setup;
- Clear profiles** – clear all memory cells;
- Firmware – 6.04** – firmware version;

All adjusted meaning and settings are stored in nonvolatile memory and will remain after AIS TESTER is turned off.

#### 5.3.5.1 Battery voltage menu – AIS TESTER batteries voltage indication

The measured voltage meaning of current power supply source is displayed on LCD:

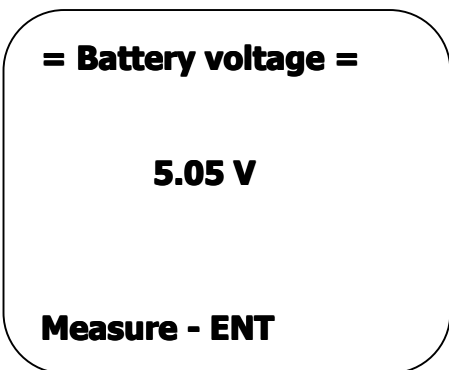

- Voltage of internal batteries, if nothing is connected to USB port;
- Voltage supplied to USB-port, if it's connected to PC or network USB-adapter.

*AIS TESTER is automatically switched to USB power supply source when connected!*

Each pressing of ENTER key will measure the voltage again.

#### 5.3.5.2 LCD contrast submenu - LCD contract adjustment

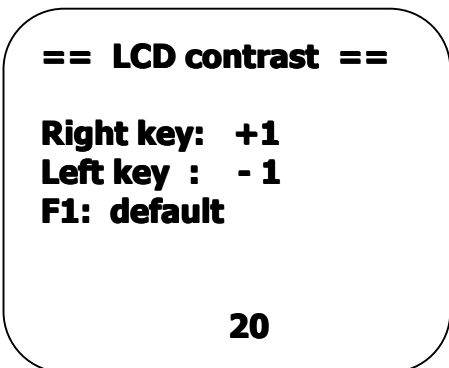

The current LCD contrast meaning is displayed in range of 10 to 32 at the bottom line:

Also following actions are available:

- Right +** - increase the LCD contrast;
- Left -** - decrease the LCD contrast;
- F1 - default** - setup default meaning – 20;

#### 5.3.5.3 Setup Date/Time

This menu allows adjusting the time and date and changing the date format to US/Europe.

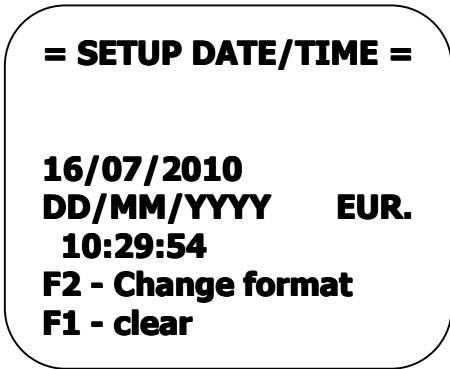

Use **Left, Right** to navigate between lines, and **Up, Down** key to change the meanings.

**Press F1** – to zero the meaning;

Press F2 to change the date format to:  
**EUR. DD/MM/YYYY** or  
**AMER. MM/DD/YYYY.**

**Press ENTER to save all changes.**

### 5.3.5.4 Clear profiles

This menu item allows to clear all memory cells or separate selected cell.

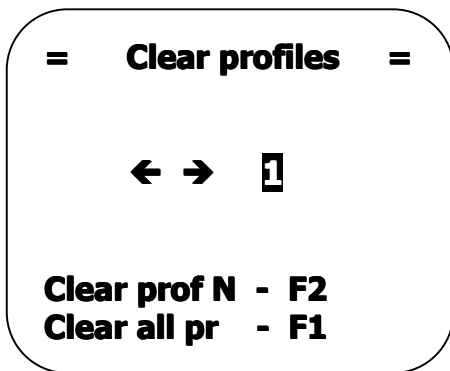

Use **F1** key to clear all memory cells/profiles.

Use **← →** to select the profile number to be cleared.

Press **F2** key when the profile number is selected to clear this profile.

### 5.3.5.5 MANUFACT SETTINGS

**MANUFACT SETTINGS** is intended for service maintenance of the AIS TESTER. This menu item contains submenus to setup and calibrate the device. It is not recommended to use this menu item without necessity.

### 5.3.6 CONNECTION TO PERSONAL COMPUTER OR LAPTOP

*The AIS TESTER can be easily connected to any personal computer or laptop by means of USB cable.*

PC AIS TESTER connection is performed via USB – channel by means of integral circuit USB – UART (USB Serial Converter) manufactured by FTDI - FT232R.

**It is necessary to install FTDI drivers for normal operation of the AIS TESTER.**

The following software installation procedure is recommended:

1. Unpack zip-file to the any specified folder on your hard disk;
2. Run AIS AIS TESTER software v2.0 (no installation required).
3. Use USB – cable (supplied) to connect device to the PC and turn the AIS TESTER on.
4. You will see the message about the new USB-device detected by the PC. Then choose CDM 2.00.xx folder as the drivers setup resource from the software package.
5. Turn the device off and disconnect it from PC;
6. Connect the device to the PC, turn it on and enter the main menu. Further data transfer process is held by the terminal program.

**NOTE: Memory saved data transfer is performed from any AIS TESTER's menu, so just turn on the AIS TESTER and run the software. PC software allows requesting data of the certain single measurement determined by the cell number or all of the ten possible memory units.**

#### **5.4. AIS TESTER operation supplied by external power source.**

As a AIS TESTER power supply unit use USB adapter which is optional included into the complete set of the device. AIS TESTER can also be power supplied by 220 V AC supply, and besides, directly from the PC USB port.

**6. Measurement of AIS station or AIS-SART parameters**

**6.1 General notes of AIS Station.**

In this section is described logical operation and criteria set, which are to use during the checking AIS station A class. They are based upon IMO / IALA recommended guideline – so, only in this case user can get one-valued and directly treat results while using the AIS AIS TESTER.

By the primary testing of the just mounted station make sure that AIS equipment is installed in proper way according to this guidance and manufacturer demands to get the successful operation of the AIS.

One of the important AIS aspects is its mobility. Together with requesting some certain operation of AIS AIS TESTER (*which is expected operation*), AIS carries out an action, according to AIS protocol of current navigation circumstances (*which are unexpected operation*).

**6.2 AIS Stations test procedure**

**6.2.1** Connect the AIS station output to the attenuator input and connect the attenuator output to the AIS TESTER input by using the HF-cable which is included to complete set of the AIS TESTER. Note that power meter is calibrated only for this type of the connection!

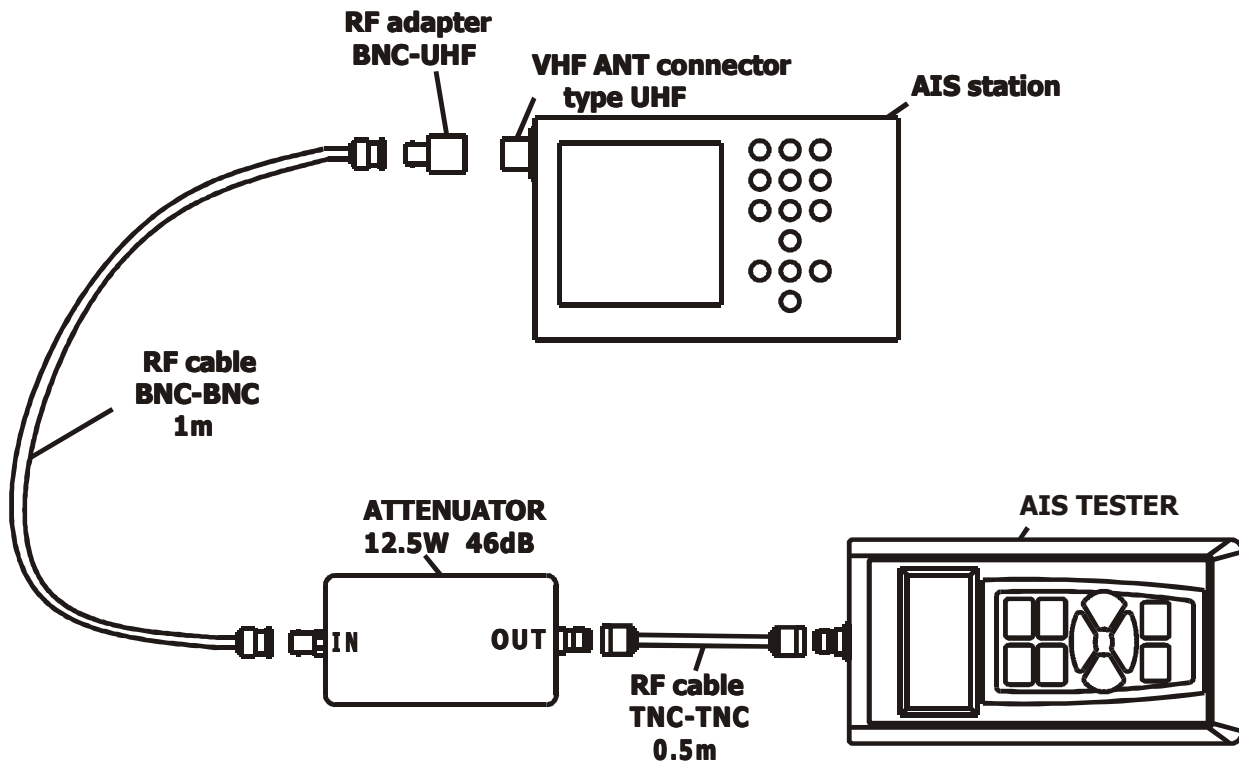

Figure 6-1. Connection of AIS AIS TESTER to AIS station by means of attenuator

Use the **TEST AIS** menu section to do all the checking!

## 6.2.2 Step 1

Enter **TEST AIS/TEST AIS CLASS A** or **TEST AIS/TEST AIS CLASS B** Menu.

In common AIS station A class is to transfer location report – message 1 at 10 seconds interval, alternating A and B channels, and AIS station class B – message 18 with 3 minutes interval, alternating A and B channels. Besides, the station has to transfer static information – message 5(Class A) and message 24(class B) at 6 minutes interval, also alternating A and B channels.

For each of the received messages the AIS AIS TESTER DSP controller calculates the deviation of the frequency and power level;

The operation algorithm in this case is as follows:

- AIS TESTER performs slot synchronization, measures power level of received signals and frequency deviation;
- AIS TESTER transmits the request to AIS station for message 5 (In test AIS/ TEST AIS Class A mode) and for message 24(In TEST AIS/TEST AIS Class B mode) in one minute;
- After the message 5 or message 24 is received by AIS TESTER the AIS TESTER transmits the “virtual ship” message with increased relatively to AIS station coordinates on 0.1 mile and with MMSI 201999998.
- After all these operations the status bar will be completed and AIS TESTER will ask to save the data by pressing F2 key for further processing.
- AIS TESTER sends the request 111 in CH70 – “Report ship’s name” in TEST AIS/Test AIS Class A mode and waits for 20 seconds for AIS Station respond, if the respond is received, the DSC note will be displayed on line 6.

Data processing is shown on the screen in sixth line by means of four item line. Each status bar item corresponds to the following information:

1. Channel A power output and frequency;
2. Channel B power output and frequency;
3. Message 1 or Message 18 - transient data, transferred according to the station inner time schedule;
4. Message 5 or Message 24 – static vessel’s data.

The result of “virtual ship” message transmitting will be displayed in AIS station LCD in view of new vessel with MMSI 201999998.

As a rule the AIS stations have LED indicators of signal transmission or reception. So, it is necessary to pay attention to these LEDs during checking. Each Tx LED illumination AIS TESTER should confirm by short sound signal and LCD data update in **AIS/Test AIS class A** or **TEST AIS/Test AIS class B** modes. The signal transmission by AIS TESTER is attended by sound signal too and AIS station Rx LED should illuminate.

If the “virtual ship” message is not received by AIS station, no new vessel with MMSI 201999998 is appeared on AIS station screen, it is necessary repeat the request from TEST AIS/ Ship emulation menu, as described in STEP 2. If the “virtual ship” message is received the next operation step is 3 – item 6.2.4

### 6.2.3 Step 2

**Choose the TEST AIS/Ship emulation menu item and select the channel, for example – Channel A.**

Press ENTER key two times – after the sound signal the message 1 with MMSI 201 999998 and increased relatively to AIS station coordinates on 0.1 mile will be sent in 2-4 seconds.

As a result the “virtual ship” / object with MMSI 201 999998 should appear on AIS station LCD screen (MKD).

It will confirm following:

1. The tested AIS station is able to receive the VDL messages in selected channel;
2. The tested AIS station has correctly connected MKD.

### 6.2.4 Step 3

**The next step is intended only for AIS station class A – checking of DSC channel polling information on 70 channel.**

Enter **Polling DSC** menu section and press the **ENTER** button twice.

After sound signal the AIS TESTER will transfer request 111 – **“Report ship’s name”** and AIS station should respond in 20 seconds. All the requesting information will appear on the screen.

If there’s no respond from the station user can see the following: **No respond** - no respond from the acquired station.

**NOTE: The last ITU-R M.1371-3 review, as opposed to previous reviews, supposes the DSC-channel usage only to control the regional AIS station channels. The respond to DSC channel is not supported.**

## 6.3 AIS-SART test procedure

Almost all AIS-SARTs have internal antenna, so we recommend to carry out the measurement through broadcast.

Connect the antenna supplied in standard delivery set to RF IN input of the AIS TESTER. Go to **TEST AIS/TEST AIS SART** menu and enter manually the AIS-SART USER ID – it should be marked on the AIS-SART case. Now AIS TESTER is ready to start measurements.

Turn on the AIS-SART to test mode and place it at 3-5 meters from AIS TESTER approximately at the same level corresponding to AIS TESTER or lower a little.

It is necessary to note that it can take up to 15 minutes before AIS-SART starts transmission of test messages. It depends on the AIS-SART capability to determine the coordinates fast by means of internal GPS receiver.

Most general it will require about 5 minutes if the GPS receiver can't determine the coordinates (closed room) and 2-3 minutes if the GPS receiver determines the coordinates(test in open places).

The AIS SART test signal in accordance with IEC 61097-14 consist of 8 messages transmitted in determined order both in A and B channels. (4 messages in every channel):

1. AIS A, Message 1, Nav Status = 15
2. AIS B, Message 1, Nav Status = 15
3. AIS A, Message 1, Nav Status = 15
4. AIS B, Message 1, Nav Status = 15
5. AIS A, Message 14, "SOME DATA"
6. AIS B, Message 14, "SOME DATA"
7. AIS A, Message 1, Nav Status = 15
8. AIS B, Message 1, Nav Status = 15

**NOTE: DO NOT TURN ON THE AIS-SART TO EMERGENCY MODE WITHOUT REAL NECESSITY.**

## **7. AIS TESTER's calibration**

AIS TESTER is dedicated complicated electronic device that's why its checking has to be performed on manufacturer site.

This checking is to be performed one time in two years.

## **8. General operation environments**

At significant temperature variations in warehouse or working room it is strongly recommended to store any AIS TESTER equipment in package about two hours before any operations.

In case of high humidity conditions it is strongly recommended to store any AIS TESTER equipment out-of-work about 12 hours.

**9. Safety precautions**

Operate the AIS TESTER is possible after reading guidance manual and a safety induction.

**10. Storage rules**

Packed equipment stocks an article to prevent water, vapor, rain and corrosion environment damages.

Storage temperature has to be from 278 K (5 ° C) to 313 K (40 ° C) and relative humidity not above 80%.

## Application 1

## Unit conversion (dBm to W).

dBm	0	0.1	0.2	0.3	0.4	0.5	0.6	0.7	0.8	0.9
20	0.100	0.102	0.105	0.107	0.110	0.112	0.115	0.117	0.120	0.123
21	0.126	0.129	0.132	0.135	0.138	0.141	0.145	0.148	0.151	0.155
22	0.158	0.162	0.166	0.170	0.174	0.178	0.182	0.186	0.191	0.195
23	0.200	0.204	0.209	0.214	0.219	0.224	0.229	0.234	0.240	0.245
24	0.251	0.257	0.263	0.269	0.275	0.282	0.288	0.295	0.302	0.309
25	0.316	0.324	0.331	0.339	0.347	0.355	0.363	0.372	0.380	0.389
26	0.398	0.407	0.417	0.427	0.437	0.447	0.457	0.468	0.479	0.490
27	0.501	0.513	0.525	0.537	0.550	0.562	0.575	0.589	0.603	0.617
28	0.631	0.646	0.661	0.676	0.692	0.708	0.724	0.741	0.759	0.776
29	0.794	0.813	0.832	0.851	0.871	0.891	0.912	0.933	0.955	0.977
30	1.00	1.02	1.05	1.07	1.10	1.12	1.15	1.17	1.20	1.23
31	1.26	1.29	1.32	1.35	1.38	1.41	1.45	1.48	1.51	1.55
32	1.58	1.62	1.66	1.70	1.74	1.78	1.82	1.86	1.91	1.95
33	2.00	2.04	2.09	2.14	2.19	2.24	2.29	2.34	2.40	2.45
34	2.51	2.57	2.63	2.69	2.75	2.82	2.88	2.95	3.02	3.09
35	3.16	3.24	3.31	3.39	3.47	3.55	3.63	3.72	3.80	3.89
36	3.98	4.07	4.17	4.27	4.37	4.47	4.57	4.68	4.79	4.90
37	5.01	5.13	5.25	5.37	5.50	5.62	5.75	5.89	6.03	6.17
38	6.31	6.46	6.61	6.76	6.92	7.08	7.24	7.41	7.59	7.76
39	7.94	8.13	8.32	8.51	8.71	8.91	9.12	9.33	9.55	9.77
40	10.00	10.23	10.47	10.72	10.96	11.22	11.48	11.75	12.02	12.30
41	12.59	12.88	13.18	13.49	13.80	14.13	14.45	14.79	15.14	15.49
42	15.85	16.22	16.60	16.98	17.38	17.78	18.20	18.62	19.05	19.50
43	19.95	20.42	20.89	21.38	21.88	22.39	22.91	23.44	23.99	24.55
44	25.12	25.70	26.30	26.92	27.54	28.18	28.84	29.51	30.20	30.90
45	31.62	32.36	33.11	33.88	34.67	35.48	36.31	37.15	38.02	38.90
46	39.81	40.74	41.69	42.66	43.65	44.67	45.71	46.77	47.86	48.98
47	50.12	51.29	52.48	53.70	54.95	56.23	57.54	58.88	60.26	61.66
48	63.10	64.57	66.07	67.61	69.18	70.79	72.44	74.13	75.86	77.62
49	79.43	81.28	83.18	85.11	87.10	89.13	91.20	93.33	95.50	97.72

Example: The power level 37.4dBm is equal to 5.5W.

The recalculation is carried out by equation:

$$P[W] = 10^{0.1 \cdot P[dBm] - 3}$$

The back calculation is carried out under:

$$P[dBm] = 10 * (\log P[W] + 3)$$