









USER MANUAL

THERMAL PRINTER
NPT-100

NOTICE TO USERS

- Thanks for your purchasing this product NPT-100 Thermal Printer.
- Please read this manual carefully to ensure proper use before installation and operation of the NPT-100.
- NSR will assume no responsibility for the damage caused by improper use or modification of the product. NSR does not make any representations or warranties (implied or otherwise) regarding the accuracy and completeness of this document and shall in no event be liable for any loss of profit or any commercial damage, including but not limited to special, incidental, consequential, or other damage.
- The software version in your product may be some different from that described as in this manual. Such differences will not affect the performance of the product. NSR reserves the right of continuous improvement on products both in software and hardware without any prior notice.
- The copyright of this manual is owned by the manufacturer, NEW SUNRISE CO., LTD (NSR). Prior written permission is required for copying or reproducing the manual or part of the manual.
- Please keep the manual for your future reference.

| SAFETY INSTRUCTIONS for the operator | |
|-----------------------------------------------------------------------------------|----------------------------------------------------------------------------------------------------------------------------------------------------------------------|
|  | <p>Warning Keep away from heater source or direct sunshine.</p> |
|  | <p>Prohibition Don't open the equipment. Only qualified personnel should work inside the equipment. Don't disassemble or try to modify the equipment.</p> |
|  | <p>Dangerous Turn off the power immediately when smoke or fire is emitted.</p> |

| SAFETY INSTRUCTIONS for the installer | |
|-------------------------------------------------------------------------------------|---------------------------------------------------------------------------------------------------------------------------------------------------------------------------------------------------------------------------------------------------|
|  | <p>Warning Connect the earthing cord to ship's body. Observe the compass safe distance to prevent deviation of an onboard magnetic compass.</p> |
|  | <p>Prohibition Don't open the equipment unless you have fully understood the structure and circuits of the equipment. Only qualified personnel should work inside the equipment. Don't disassemble or try to modify the equipment.</p> |
|  | <p>Dangerous Turn off the power at power distribution board before installation.</p> |

MODIFY RECORD

| No. | Modify by | Date | Paragraph | Version | Reason |
|-----|-----------|------------|-----------|---------|--------------------------------------|
| 1 | Q/A | 2013/09/01 | | 01 | First edition |
| 2 | Q/A | 2013/12/01 | 4, 5 | 02 | Add the description of port settings |
| 3 | Q/A | 2024/05/07 | all | 03 | Add drawing, update the layout |
| 4 | Q/A | 2025/02/06 | all | 04 | Some modification |

CONTENTS

| | | |
|----------|-----------------------------------------------|-----------|
| 0 | BRIEF INTRODUCTION..... | 1 |
| 1 | FEATURES | 2 |
| 2 | EXTERNAL DIMENSIONS AND PART NAME..... | 4 |
| 3 | OPERATION | 5 |
| 4 | FUNCTION SETTING | 7 |
| 5 | PORT CONNECTION..... | 10 |
| 6 | CONTROL COMMAND..... | 11 |
| | Appendix 1 TABLE OF CHARACTERS | 12 |
| | Appendix 2 SIZE DRAWING..... | 13 |

0. Brief Introduction

Thank you for purchasing the NPT-100 thermal printer.

This USER'S MANUAL explains how to handle NPT-100 thermal printer (hereinafter referred to as printer),

NPT-100 thermal printer adopts Seiko printer head with the features of high speed, high-quality, high reliability, low noise, compact size and easy operation .

NPT-100 can be used for a wide range of marine applications, e.g. Navtex receiver, Inmarsat C, and Anemometer.

Once you have opened the carton, make sure it contains the printer and all accessories.

- Printer
- Thermal paper
- AC/DC adaptor
- Short connection cable with RS232 connector
- Manual

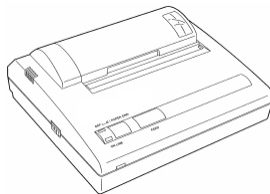

Printer



Thermal paper



Manual

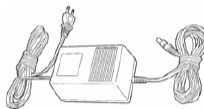

AC/DC adaptor

1. Features

1.1 General Specifications

| | |
|---------------------|-------------------------------------------------------------|
| Printing Method | Thermal dot line printing |
| Printing width: | 80 mm , 640 dot / Dot per line |
| Resolution: | 8 dots /mm |
| Paper width | 111.5±0.5 mm |
| Printing speed: | Low speed or high speed |
| printing head life: | 100 million pulse or more(at 25℃ and at rated power supply) |

1.2 Printing paper :

| | |
|-------------------|-----------------------------------------------------------------------------------------------------------|
| Paper loading: | Easy lading of paper with a detachable platen unit. |
| Paper parameters: | External diameter:Φ 40mm Internal diameter:Φ12mm Thickness 53~60g/111.5±0.5 mm high or low speed |

1.3 Character matrix :

ASC II character: 16 dot wide×24 dot high, 2.00 (W)×3.00 (H) mm

1.4 Interface:

Parallel port and serial port. No setting required, automatic detection.
Serial port can be set at the baud rate of 2400/4800/9600/19200/38400/115200 bps.

1.5 Printing control command:

- The printing control command has a good compatibility with the traditional printer
- Character printing command supports to print out ASC II character in double width and double high
- Graphics printing command supports to print out different graphical dot array vertically and horizontally .
- Support the printing under the Windows 9x、 Windows2000、 Windows XP Operation System.

1.6 Power Supply:

- DC8V or AC100V/50-60Hz (with adaptor)
- Mean current: 3(A) at DC8V
- Peak current: 5(A) at DC8V

1.7 Environmental conditions:

- Operating temperature : 0~40℃
- Relative humidity: ≤80%RH
- Storage temperature : -20~ 60℃
- Storage Relative humidity: 10~90%RH

2. External dimensions and part name

External dimensions (160x170x66mm)

Paper cover

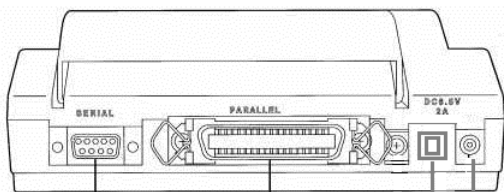
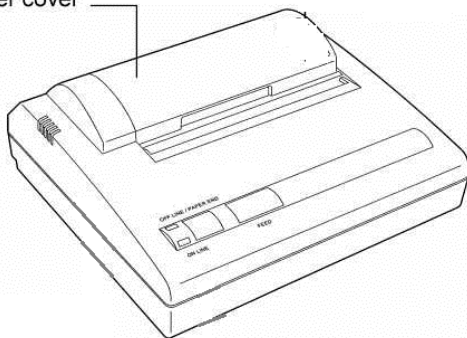

serial port

parallel port

switch

power input

ON/OFF LED

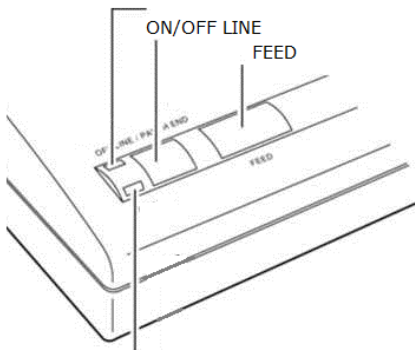

POWER LED

3. Operation

3.1 Loading paper

- When the printer detects the signal of no paper, the **ON/OFF LED** (green) will blink.
- Open the paper cover by pressing push-button on the right side.
- Put the paper roll into the paper holder as below photo.



- Close the paper cover.
- The **ON/OFF LED** stops blinking.
- If the paper deviates to one side, press the **FEED** button to correct the error.

Attention:

The thermal surface of printing paper must towards the inside.

3.2 State indicators

The printer has two indicators, the **POWER** LED (red) as a power indicator and the **ON/OFF LED** (green) as a state indicator.

ON/OFF LED states:

- light on, indicating the printer in on-line state.
- light off, indicating the printer in off-line state.
- blink, indicating the printer in unusual warning state or in setting state.

3.3 **ON/OFF LINE** button

In the on-line mode, the **ON/OFF LED** is on.

Press the **ON/OFF LINE** button, then the **ON/OFF LED** is off and the printer is off-line. In this state, the printer can not receive the data.

Press the **ON/OFF LINE** button again, and the printer is on-line again.

3.4 **FEED** button

In the on-line state, press the **FEED** button and the feed paper motor will be started. The printer feeds the paper.

Press the **FEED** button again to stop feeding paper.

3.5 Self-test

The self-test procedure can examine whether the printer works normal and what the current parameters are.

If a self-test list can be correctly printed out, the printer is in good state.

- Press **ON/OFF LINE** button to leave the printer into off-line state (the **ON/OFF LED** off).
- Press the **ON/OFF LINE** button again and the **ON/OFF LED** will blink once.
- Press the **ON/OFF LINE** button immediately to leave the printer into self-test procedure.
- The printer can print out the ASCII character table and current parameters of all setting items.

4. Function Setting

4.1 Items to be set

The below items can be set by different combination of buttons and LEDs

| NO | ITEM | PARAMETERS |
|----|-----------------------------|-----------------------------------------------------------------------------------------------------------------|
| 1 | Interface | Parallel port and serial port (No setting required, automatic detection) |
| 2 | Printing speed | Low speed or high speed |
| 3 | Data control of serial port | DTR or X-on/X-off (No setting required, default is on) |
| 4 | Baud rate of serial port | 115200, 38400, 19200, 9600, 4800, 2400 bps |
| 5 | Printing resolution | Standard printing or fine printing |
| 6 | Printing mode | Line printing: Character matrix (8X16 dots) or page printing: Character matrix (16X24 dots or 16X16 dots) |
| 7 | Character matrix | 16x24 dots, 16x16 dots or 8x16 dots |
| 8 | Line dot | 640, 832 |

4.2 Setting method

- Press the **ON/OFF LINE** button, then **ON/OFF LED** off and the printer is off-line.
- Press the **ON/OFF LINE** button again until **ON/OFF LED** blinks twice and then release the button. The printer is on-line and prints out the current parameter of the first item.
- Press the **ON/OFF LINE** button step by step to print the current parameter of the setting items in below order:

Baud rate→

High Speed Printing→

Front→

Line Dot→

Standard printing→

Page Mode→

- When printing the parameter of one item among above, press the **FEED** button to change parameter of the item.
- Press the **ON/OFF LINE** button again to save the current parameter and enter next setting item.

4.3 Setting example

In the below table, the middle column shows the current parameters (as printed in self-test). The right column shows the target parameter you

expect to set into.

| Item Name | Current Parameter | Target Parameter |
|--------------------------|----------------------|----------------------|
| Printing speed | High speed | Low speed |
| Baud rate of serial port | Baud rate 4800 | Baud rate 19200 |
| Printing resolution | Standard printing | Fine printing |
| Printing mode | Page printing | Page printing |
| Character matrix | Character 16X24 dots | Character 16X16 dots |

Operation steps:

STEP 1:

Press the **ON/OFF LINE** button to enter next setting item. “**High Speed**” is printed out.

Press the **FEED** button to change the parameter. “**Low Speed**” is printed out.

STEP 2:

Press the **ON/OFF LINE** button to enter next setting item. “**Baud rate 4800**” is printed out.

Press the **FEED** button to change the parameter. “**Baud rate 9600**” is printed out.

Press the **FEED** button to change the parameter. “**Baud rate 19200**” is printed out.

STEP 3:

Press the **ON/OFF LINE** button to enter next setting item. “**Standard printing**” is printed out.

Press the **FEED** button to change the parameter. “**Fine printing**” is printed out.

STEP 4:

Press the **ON/OFF LINE** button to enter next setting item. “**Page printing**” is printed out.

STEP 5:

Press the **ON/OFF LINE** button to enter next setting item. “**Character 16X24 dots**” is printed out.

Press the **FEED** button to change the parameter. “**Character 16X16 dots**” is printed out.

STEP 6:

Press the **ON/OFF LINE** button to save all new parameters.
All new parameters can be printed out if self-test is carried out.

5. Port Connection

5.1 Port description of RS-232 connector

| Pin No. | Description | Direction | Remarks |
|---------|-------------|-----------|----------------------------------------|
| 1 | NC | | NO USED |
| 2 | TXD | output | The printer sent out "X-on/X-off" code |
| 3 | RXD | input | The printer receives data |
| 4 | NC | | NO USED |
| 5 | GND | | |
| 6 | NC | | NO USED |
| 7 | NC | | NO USED |
| 8 | RTS | output | Data send request |
| 9 | NC | | |

5.2 The connecting between the printer and PC

| Pin No. | PC or Marine equipment | Printer |
|---------|------------------------|---------|
| 1 | | |
| 2 | RXD | TXD |
| 3 | TXD | RXD |
| 4 | | |
| 5 | GND | GND |
| 6 | | |
| 7 | | |
| 8 | CTS | RTS |
| 9 | | |

Data format:

Parity: nothing, odd number, even number
 Data control: : x-on / x-off
 Data bit length: 8 bit
 Stop bit length: 1 bit (fixed)

5.3 Baud rate:

2400/4800/9600/19200/38400/115200bps
 (factory default 4800bps)

6. Control command

| ASC II | Function |
|------------|-------------------------------------------|
| NUL | End symbol |
| HT | Horizontal tab |
| LF | Print and line feed |
| VT | Vertical tab |
| CR | Print and carriage return |
| CAN | Cancel the character in current line |
| ESC ESC | Set West word printing mode |
| ESC FS | Set Chinese word printing mode |
| ESC % | Permit /prohibit User |
| ESC & | Set Use-definable character |
| ESC +n | Set/Reset superscript line print |
| ESC -n | Set/Reset subscript line paint |
| ESC 1A | Set n- dot line feed |
| ESC @ | Reset the Printer |
| ESC B | Set Vertical tab value |
| ESC D | Set horizontal tab va |
| ESC J | Print and feed paper n |
| ESC Q n | Set right margin |
| ESC... U n | Set character was printed in double |
| ESC V n | Set character was pointed in double |
| ESC W n | Set character was printed in double width |
| ESC f m n | Print n-space/n |
| ESC l | Set/cancel inverted colour pint |
| ESC 1n | Set left man gin |
| ESC m | Cutting paper command |

Graphical printing command

| | |
|-------|-------------------------------------------|
| ESC * | Set dot graphic command |
| ESC k | Set dot graphic command |
| ESC(| Set dot graphic command |
| ESC | Set dot graphic command |
| ESC | Set dot graphic command |
| ESC, | Print curve command |
| ESC x | Set bit image graphic printing in the ROM |
| G/ n | Print the bit image graphic in the ROM |

Appendix 1 Table of Characters

| HEX | 0 | 1 | 2 | 3 | 4 | 5 | 6 | 7 | 8 | 9 | A | B | C | D | E | F |
|-----|---|---|---|---|----|---|---|---|-----|---|---|---|---|---|---|---|
| 2 | | ! | " | # | \$ | % | & | , | { } | * | + | , | | . | / | |
| 3 | 0 | 1 | 2 | 3 | 4 | 5 | 6 | 7 | 8 | 9 | : | . | < | = | > | ? |
| 4 | @ | A | B | C | D | E | F | G | H | I | J | K | L | M | N | O |
| 5 | P | Q | R | S | T | U | V | W | X | Y | Z | [| \ |] | ^ | |
| 6 | | a | b | c | d | e | f | G | h | i | j | k | l | m | n | o |
| 7 | p | q | r | s | t | u | v | W | x | y | z | { | | } | ~ | |
| 8 | | | | | | | | | | | | | | | | |
| 9 | | | | | | | | | | | | | | | | |

Appendix 2 Drawings

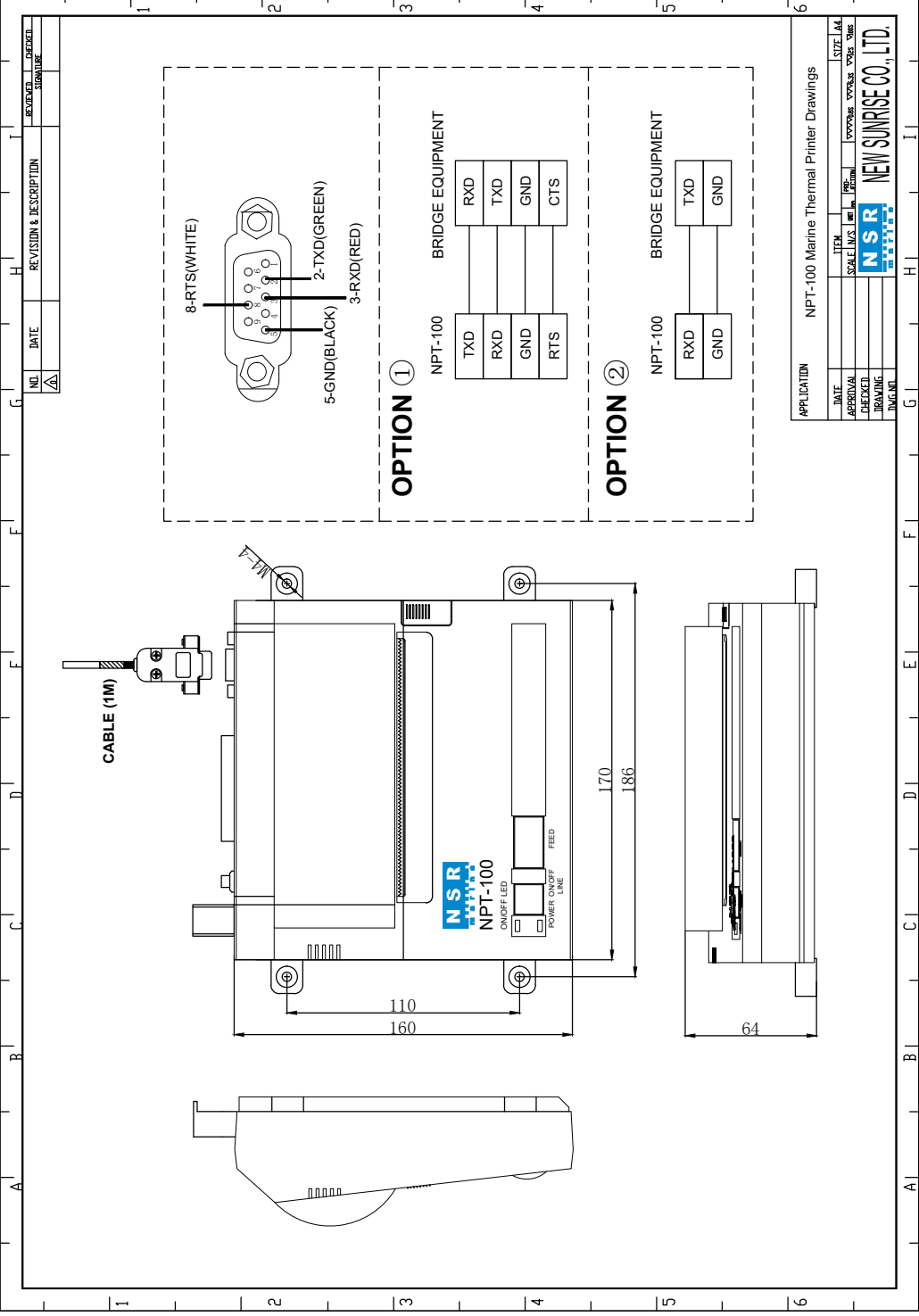

| | | | | |
|-----|------|------------------------|------------|------------|
| NO. | DATE | REVISION & DESCRIPTION | REVISED BY | CHECKED BY |
| | | | | |

| | | | | |
|------------------------------------------------------|---------|---------|--------|------|
| APPLICATION: NPT-100 Marine Thermal Printer Drawings | | | | |
| DATE | ITEM | SCALE | INSTR. | SIZE |
| | | | | |
| APPROVAL | CHECKED | DRAWING | DATE | |
| | | | | |
| NSR NEW SUNRISE CO., LTD. | | | | |

Copyright by NEW SUNRISE CO., LTD. (NSR)

www.nsrmarine.com

info@nsrmarine.com

February, 2025