



Canopy[®] LENS User's Guide

LENS-UG-en

Issue 2

January 2008



*MOTO***WI**⁴

Notices

See important safety notice on exposure distance in Section 7.3 on page 22.

See important regulatory and legal notices in Section 7 on page 17.

Trademarks, Product Names, and Service Names

MOTOROLA, the stylized M Logo, Canopy, and all other trademarks indicated as such herein are registered trademarks of Motorola, Inc. ® Reg. US Pat & Tm. Office. MOTOWi4 is a trademark of Motorola, Inc. All other product or service names are the property of their respective owners.

© 2008 Motorola, Inc. All rights reserved

<http://www.motorola.com/canopy>

Table of Contents

1	Introduction	4
2	Product Description	6
3	Features	8
4	Planning	9
5	Configuration	12
6	Installation	16
7	Regulatory and Legal Notices	17

List of Tables

Table 1: Information on LENS	6
Table 2: Information on LENS installed on Canopy Module.....	7
Table 3: PtMP – SM or AP Settings and Typical Maximum Ranges when using a LENS	13
Table 4: PtP - BH settings and Typical Maximum Ranges when using a LENS.....	14
Table 5: US FCC IDs and Industry Canada Certification Numbers and Covered Configurations	17
Table 6: Disclosure Table	22
Table 7: Exposure Separation Distances	22
Table 8: Calculated Exposure Distances and Power Compliance Margins	23

List of Figures

Figure 1: LENS installed on Canopy module, front and back views	6
---	---

1 Introduction

This User's Guide describes the Canopy LENS and covers planning, installation, and configuration associated with the LENS.

1.1 ABBREVIATIONS

The following abbreviations may be used in these notes:

1X	1X operation, with typical max aggregate (up and down) throughput of 7 Mbps (2 Mbps for 900 MHz)
2X	2X operation, with typical max aggregate (up and down) throughput of 14 Mbps (4 Mbps for 900 MHz)
AP	Access Point Module
BH	Backhaul Module, either timing master or timing slave
BHM	Backhaul Module – timing master
BHS	Backhaul Module – timing slave
CMM	Cluster Management Module
CNUT	Canopy Network Updater Tool
DFS	Dynamic Frequency Selection for radar avoidance
EIRP	Equivalent Isotropically Radiated Power
ETSI	European Telecommunications Standards Institute
MIB	Management Information Base for SNMP
P7/P8/P9/P10	Shorthand for hardware series levels
PtP	Point-to-Point (Backhauls)
PtMP	Point-to-Multi-Point (AP to SMs)
RF	Radio Frequency
SM	Subscriber Module

1.2 DOCUMENT CHANGE HISTORY

Issue 2	Wording changes to avoid giving the impression the LENS is an antenna. (It focuses RF energy, but is not itself a producer of RF energy.) Several small changes for readability and clarity.
Issue 1a	First Issue.

1.3 FEEDBACK ON DOCUMENTATION

Is this document accurate, complete, and clear? How can it be improved? Please send your feedback on Canopy documentation to technical-documentation@canopywireless.com.

1.4 TECHNICAL SUPPORT

Tip! Don't clear the Event Log after you encounter issues – it may be useful to Technical Support if you need to escalate the issue.

Here is the escalation path for resolution of a problem:

1. Check documentation:
 - This document
 - Canopy System Release 8 User's Guide, available at <http://motorola.canopywireless.com/support/library/>
2. Consider checking the Canopy Community Forum at <http://motorola.canopywireless.com/support/community>.
3. Consider checking the Canopy Knowledge Base at <http://motorola.canopywireless.com/support/knowledge/>
4. Escalate the problem to your Canopy supplier or reseller.
5. Escalate the problem to Canopy Technical Support or other designated Tier 3 technical support:

Worldwide Canopy Technical Support

email: technical-support@canopywireless.com

1-888-605-2552 or +1 217 824 9742

Canopy Technical Support, Europe

email: essc@motorola.com

+44 (0)1793 564680

Calls are logged 24 x 7, cases are worked Mon-Fri 09:00 - 17:00 GMT

When you send e-mail or call, please include, as appropriate, software release on each module, IP addresses, MAC addresses, and features enabled, like NAT, VLAN, high priority channel, or CIR. You may be asked to run the Support Tool on CNUT or Prizm to provide a complete network picture.

2 Product Description

The Canopy® LENS is a non-electronic unit, made of a special high-density plastic, that snaps onto a Canopy 5.2, 5.4, or 5.7 GHz module to provide 9 to 10 dB of gain and reduce the 3 dB beam width from 60° to 18° in both elevation and azimuth.

Figure 1 shows the LENS installed on a Canopy module.

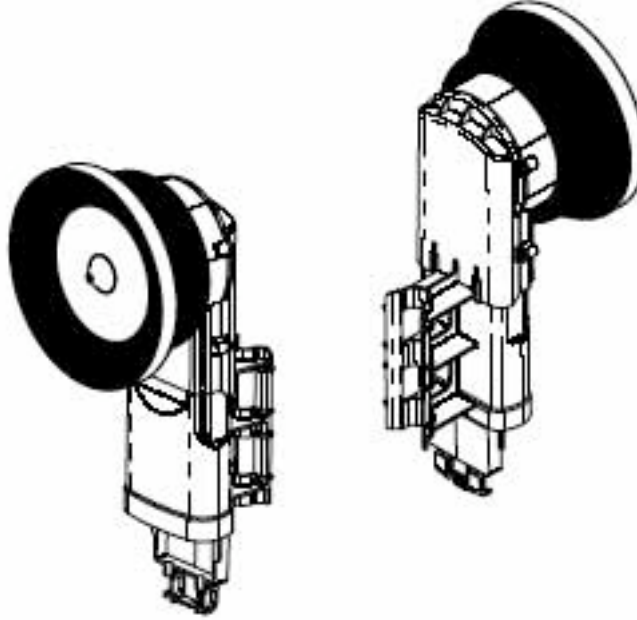

Figure 1: LENS installed on Canopy module, front and back views

Table 1 and Table 2 list information on the LENS.

Table 1: Information on LENS

Model No.	AN500A
Gain	10 dB @ 5.7 GHz 9 dB @ 5.4 GHz and 5.2 GHz
Size (nominal)	6 ¾ in x 6 in x 4 in (h x w x d) 17 cm x 15 cm x 100 cm (h x w x d)
Weight	1.75 lbs (0.8 k)
Material	High density RF plastic
Fit	Positive, secure snap-on, with easy removal. No tools required.
Temperature range	-40 to +131° F (-40 to +55° C)
UL listed	Yes

Table 2: Information on LENS installed on Canopy Module

Typical Maximum Range	<p>PtMP 5.7 GHz US and Canada: 1X operation: 5 mi (8 km) 2X operation: 2.5 mi (4 km)</p> <p>PtMP 5.2 and 5.4 GHz (EIRP limited to 30 dBm): 1X operation: 2 mi (3.2 km) 2X operation: 2 mi (3.2 km) (uplink is 1X outside of 1 mi (1.6 km))</p> <p>2X operation requires Advantage AP, and provides 14 Mbps max aggregate throughput. 1X operation provides 7 Mbps max aggregate throughput.</p> <p>PtP 5.7 GHz US and Canada: 1X operation: 16 mi (~25 km) 2X operation: 8 mi (~13 km)</p> <p>PtP 5.2 and 5.4 GHz (EIRP limited to 30 dBm): 1X operation: 6 mi (~10 km) 2X operation: 3 mi (~5 km) 2X operation requires PTP 100 (BH20).</p>
3 dB Beamwidth	18° azimuth, 18° elevation
US FCC	Covered under module's FCC ID 5.2 GHz: ABZ89FC3789 5.4 GHz: ABZ89FT7623 5.7 GHz: ABZ89FC5804
Industry Canada	Covered under module's IC Certification Number 5.2 GHz: 109W-5200 5.4 GHz: 109W-5400 5.7 GHz: 109W-5700
Europe Declaration of Conformance	5.4 GHz: See Declaration of Conformance at http://www.canopywireless.com/doc.php
Minimum Exposure Distance	20 in (0.5 m) along the beam direction during sustained exposure
Wind Loading	21.4 lbf at 120 mph (95.2 N at 193 kph) (compared to 15.1 lbf (67.2 N) for Canopy module without LENS)

Not all products are available in all regions or in all markets - please check with your Canopy distributor or reseller for availability.

3 Features

The LENS is an intermediate option between a regular Canopy module and a module equipped with a reflector. The LENS offers better range and interference management than a regular Canopy module, and better wind loading, aesthetics, and mounting than a reflector. Specific benefits for different cases are covered in the following paragraphs.

Case 1: For **Point-to-Multi-Point (PtMP) in 5.7 GHz** in US, Canada, Brazil, and countries or regions with similar regulatory requirements, regulations on EIRP will allow the LENS to be used on an SM without reducing the transmit power of the module. In this case, benefits include

- Longer range than a regular SM
- Extended range for two-way 2X operation, which can provide higher throughput for subscribers and additional sector capacity for the operator. (2X operation requires an Advantage AP.)
- Improved interference management compared to a regular SM due to the narrower beam.

Case 1A: An extension of Case 1 is when a LENS is used on a **5.7 GHz AP**. Regulations in US, Canada, Brazil, and countries or regions with similar regulatory requirements limit the AP to 36 dBm EIRP. This requires that the transmit power of the AP be reduced when the LENS is used, but still extends the range benefits of Case 1. A trade-off is that the narrower beam width of the AP must be included in planning.

Case 2: For **PtMP in 5.2 and 5.4 GHz** in Europe, US, Canada, Brazil, and countries or regions with similar regulatory requirements, EIRP limits of 30 dBm require that the transmit power of the module be reduced when the LENS is used. In this case, benefits include

- Extended range for downlink 2X operation, which can provide higher downlink throughput for subscribers and additional sector downlink capacity for the operator. (2X operation requires an Advantage AP.)
- Improved interference management compared to a regular SM due to the narrower beam.

Case 2A: An extension of Case 2 is when a LENS is used on a **5.2 or 5.4 GHz AP**. Regulations in Europe, US, Canada, Brazil, and countries or regions with similar regulatory requirements limit the AP to 30 dBm EIRP. This requires that the transmit power of the AP be reduced when the LENS is used, but still extends the range benefits of Case 2. A trade-off is that the narrower beam width of the AP must be included in planning.

Case 3: For **Point-to-Point (PtP) (Backhuls) in 5.2, 5.4, and 5.7 GHz**, installing a LENS on both modules offers

- Extended range for 1X (BH10) and 2X (BH20) operation, compared to regular BHs without reflectors. The range extension varies based on EIRP regulations for a given region or country – see section 4 on page 9 for details.
- Improved interference management compared to a regular BH without reflector, due to the narrower beam.

4 Planning

The following paragraphs describe planning useful for LENS deployment. The same information is summarized in Table 3 and Table 4 on pages 13 and 14 for PtMP and PtP deployments respectively.

Range

Case 1: For PtMP in 5.7 GHz in US, Canada, and countries or regions with similar regulatory requirements, regulations on EIRP will allow the LENS to be used on and SM without reducing the transmit power of the module. In this case, the 10 dB of gain translates into about 2.5 times the range, extending

- 1X operation to a typical maximum range of 5 miles (8 km) and
- 2X operation to a typical maximum range of 2.5 miles (4 km). (2X operation requires an Advantage AP.)

Case 1A: When a **5.7 GHz AP** is equipped with a LENS, transmit power must be reduced to remain under 36 dBm EIRP in most countries and regions, but the 10 dB of receive gain can still give additional range for both 1X and 2X operation, with actual ranges varying based on whether the SM also has a LENS. This case is more likely to be of use when providing broadband access to a corridor, rather than to a wide geographical area, due to the reduction of sector angle from 60° to 18°.

Case 2: For PtMP in 5.2 and 5.4 GHz in Europe, US, Canada, Brazil, and countries or regions with similar regulatory requirements, regulations on EIRP require that the transmit power of the module be reduced when the LENS is used - transmit power must be reduced to offset the LENS gain to remain under an EIRP limit of 30 dBm:

- typical maximum range is not increased by using the LENS and remains at 2 mi (3.2km), as the uplink link budget is not increased
- 2X downlink operation is possible over the entire 2 miles (3.2 km) because the downlink enjoys an increased link budget due to the LENS on the SM. (2X operation requires an Advantage AP.)

Case 2A: When a **5.2 GHz or 5.4 GHz AP** is equipped with a LENS, transmit power must be reduced to remain under 30 dBm EIRP, but the 9 dB of receive gain can still give additional range for both 1X and 2X operation if the SM also uses a LENS. This case is more likely to be of use when providing broadband access to a corridor, rather than to a wide geographical area, due to the reduction of sector angle from 60° to 18°.

Case 3: For PtP (Backhuls) in all bands, range is increased.

- For 5.7 GHz in US, Canada, and countries or regions with similar regulatory requirements, regulations on EIRP will allow the LENS to be used without reducing the transmit power of the module. In this case, the 10 dB of gain on each end translates to 16 mi (about 25 km) of range at 1X for 10 Mbps BHs (BH10s), and 8 mi (about 13 km) of range at 2X for 20 Mbps BHs (BH20s).
- For 5.2 and 5.4 GHz in Europe, US, Canada, Brazil, and countries or regions with similar regulatory requirements, regulations on EIRP require that the transmit power of the module be reduced when the LENS is used - transmit power must be reduced to offset the LENS gain to remain under an EIRP limit of 30 dBm. In this case, the 9 dB of gain on each end translates to 6 mi (about 10 km) of range at 1X for 10 Mbps BHs (BH10s), and 3 mi (about 5 km) of range at 2X for 20 Mbps BHs (BH20s).

Subscriber Throughput and Coverage Area

In **Case 1**, using the LENS on SMs increases the area over which 2X throughput (both downlink and uplink) can typically be offered by a factor of 5.25 (2.5^2). With SMs outside 1 mile (1.6 km) using the LENS, a typical 6-sector tower of Advantage APs can cover almost 19 square miles (over 50 km^2) with 2X operation, versus about 3 square miles (about 8 km^2) without using the LENS.

Case 1A, with a LENS also on the AP, changes the shape of the area of 2X operation to more of a corridor instead of a wide geographical area.

In **Case 2**, using the LENS on SMs increases the area over which 2X *downlink* throughput can typically be offered by a factor of 4. With SMs outside 1 mile (1.6 km) using the LENS, a typical 6-sector tower of Advantage APs can cover over 12 square miles (over 30 km^2) with 2X operations, versus about 3 square miles (about 8 km^2) without using the LENS. The coverage area of *uplink* 2X operation is not extended, as the AP does not typically have a LENS and therefore the uplink does not enjoy the improved link budget. However, since downlink is often the direction in which high throughput is desired, using a LENS to increase downlink throughput but not uplink throughput may be very desirable in some systems and sectors.

Case 2A, with a LENS also on the AP, changes the shape of the area of 2X operation and extends the range compared to only having the LENS on the SM in 5.4 GHz or 5.2 GHz.

To put some typical throughput numbers around this, if the "Downlink Data %" on the "Configuration => Radio" page is set to 75%, then 2X downlink can reach 10.5 Mbps and 2X uplink can reach 3.5 Mbps, while 1X downlink can reach 5.25 Mbps and 1X uplink can reach 1.75 Mbps.

Sector Capacity

When the LENS extends the range over which 2X operation is possible, it not only provides the possibility of greater throughput to an individual subscriber, it also increases the capacity of the sector. Even if individual subscribers aren't offered additional throughput (even if they are rate limited using Maximum Information Rate settings or other methods), 2X can still be of significant benefit to an operator by increasing the capacity of the sector.

Think of it this way: a subscriber running at 1X who can be improved to 2X by use of a LENS uses half the "air time" to handle the same traffic, freeing up air time for other subscribers. For sectors often operating at capacity, putting a LENS on heavy-use subscribers who are currently at 1X may offer the operator additional capacity on the sector.

Table 3 on page 13 shows the typical maximum ranges by frequency band, along with downlink and uplink operation (2X or 1X) and required configuration settings.

RF Management

The narrower beam created by the LENS can reduce interference seen by the module, as well as manage interference created by the module. One work practice is to supply installers with LENSEs to use on an as-needed basis. The simplicity of snapping a LENS on and off leads to easy comparison and decision whether it is useful or needed for a given installation.

For modules required to use DFS, the narrower beam created by the LENS may reduce interference or off-bore-site radar signals that may trigger false positive radar detections. Again, the simplicity of snapping a LENS on and off leads to easy comparison and decision whether it is useful or needed for a given installation.

Restrictions

The LENS must *not* be used on P7, P8, or P9 hardware series 5.2 GHz modules in the United States and Canada, as these modules do not support a calibrated reduction in transmit power required to meet EIRP regulations in the 5.2 GHz band.

Due to the physics of RF at 2.4 GHz, the LENS provides no benefit to 2.4 GHz modules and should not be used with them.

5 Configuration

The Canopy module that a LENS is installed on

- may need to be configured for reduced **Transmitter Output Power**. For example, in most countries and regions, regulations on the 5.4 GHz and 5.2 GHz bands require that the Transmitter Output Power be no more than **14 dBm** when a LENS is used.
- may need to be configured for **External Antenna Gain** depending on type of module, region, and frequency band. For example, in Europe and Brazil operators will want to set the External Antenna Gain on SMs to **9 dB** when a LENS is used.

Table 3 on page 13 and Table 4 on page 14 show the required settings for PtMP and PtP respectively, which are then discussed in following paragraphs.



IMPORTANT!

It is the responsibility of the operator and professional installer to ensure Transmitter Output Power is set within regulatory limits for their country or region. These must be set on initial configuration and after a module is reset to factory defaults, and should be confirmed after the software on a module is upgraded.

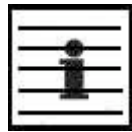

NOTE:

If using a LENS on a module operating with DFS, ensure the module is using at least Release 8.2 software, so that the External Antenna Gain parameter appears and can be set to ensure the module is appropriately sensitive (but not overly sensitive) to radar.



NOTE:

To get the throughput advantages of 2X operation, you must be using an Advantage AP (or BH20s) and the modules must be enabled for 2X Rate under MAC Control Parameters on the Configuration => General page of the AP and SM (or both BHs).

Table 3: PtMP – SM or AP Settings and Typical Maximum Ranges when using a LENS

Region			Module and Frequency Band	Module settings		Resulting Max Range (Typical)	Down-link Oper-ation ³	Up-link Oper-ation ³			
U	E	B		Transmitter Output Power ¹	External Antenna Gain ² (on modules with DFS)						
U S C a n a d a	E u r o p e	B r a z i l	5700SM (5.7 GHz)	Up to equipment max of 23 dBm	Not applicable	5 mi (8 km)	1X	1X			
						2.5 mi (4 km)	2X	2X			
			X	X		5700AP ⁴ (5.7 GHz)	Up to 19 dBm	Not applicable	Varies based on if SM also has LENS		
			X	X	X	5400SM (5.4 GHz)	Up to 14 dBm	9 dB	2 mi (3.2 km)	2X	1X
									1 mi (1.6 km)	2X	2X
			X	X	X	5400AP ⁴ (5.4 GHz)		Varies based on if SM also has LENS			
			X			5200SM (5.2 GHz, P10 hardware)		Not applicable	2 mi (3.2 km)	2X	1X
									1 mi (1.6 km)	2X	2X
			X			5200AP ⁴ (5.2 GHz, P10 hardware)		9 dB	Varies based on if SM also has LENS		
			X			Older 5200 (5.2 GHz, pre-P10)	LENS not allowed				
5.7, 5.4, 5.2 GHz with no LENS, for comparison			Up to equipment max of 23 dBm	0 dB	2 mi (3.2 km)	1X	1X				
					1 mi (1.6 km)	2X	2X				

Notes:

- 1: **Transmitter Output Power** is set on the “Configuration => Radio” page of a module.
- 2: **External Antenna Gain** is set on the “Configuration => Radio” page of a module and is only displayed if the module is using DFS, for example 5.4 GHz SMs in Europe and Brazil. The value entered in the External Gain field does not affect the transmitter power. The radio transmits at the level entered in the Transmitter Output Power. The module only uses the values entered in the External Antenna Gain field to adjust DFS sensitivity, not to change transmitter power.
- 3: 2X operation requires Advantage AP and gives a typical maximum aggregate (uplink plus downlink) throughput or capacity of 14 Mbps. 1X operation gives a typical maximum aggregate throughput or capacity of 7 Mbps. Sectors with some SMs operating at 2X and some operating at 1X at a given instant will have a pro-rated typical maximum aggregate throughput or capacity at that instant.
- 4: Special use of an AP, as LENS gives only an 18° sector.

Table 4: PtP - BH settings and Typical Maximum Ranges when using a LENS

Region	Module and 1X or 2X operation ³			BH settings		Typical Range, unit on both ends		
				Transmitter Output Power ¹	External Antenna Gain ² (on modules with DFS)	Regular module	With LENS	With Reflector
X		X	5700BH (1X) (PTP 58100 Lite)	Up to equipment max of 23 dBm	Not applicable	2 mi 3.2 km	16 mi ~25 km	35 mi 56 km
X		X	5700BH20 (2X) (PTP 58100)			1 mi 1.6 km	8 mi ~13 km	35 mi 56 km
X	X	X	5400BH (1X) (PTP 54100 Lite)	Up to 14 dBm	9 dB	2 mi 3.2 km	6 mi ~10 km	10 mi 16 km
X	X	X	5400BH20 (2X) (PTP 54100)			1 mi 1.6 km	3 mi ~5 km	5 mi 8 km
X			5200BH (1X) (PTP 52100 Lite)			2 mi 3.2 km	6 mi ~10 km	10 mi 16 km
X			5200BH20 (2X) (PTP 52100)			1 mi 1.6 km	3 mi ~5 km	5 mi 8 km
X			Older 5200BH, 5200BH20 (5.2 GHz, pre-P10)	LENS not allowed				

Notes:

- 1: **Transmitter Output Power** is set on the "Configuration => Radio" page of a module.
- 2: **External Antenna Gain** is set on the "Configuration => Radio" page of a module and is only displayed if the module is using DFS. The value entered in the External Gain field does not affect the transmitter power. The radio transmits at the level entered in the Transmitter Output Power. The module only uses the values entered in the External Antenna Gain field to adjust DFS sensitivity, not to change transmitter power.
- 3: 2X operation requires a BH20 and gives a typical maximum aggregate (uplink plus downlink) throughput (or capacity) of 14 Mbps. 1X operation gives a typical maximum aggregate throughput of 7 Mbps.

Transmitter Output Power must be set so that EIRP is within regulatory limits for a given Region and Frequency Band. In many countries or regions, 5.2 GHz and 5.4 GHz EIRP is limited to 30 dBm (1W), and the maximum Transmitter Output Power must be reduced by 9 dBm, from 23 dBm to 14 dBm, to offset the 9 dB gain of the LENS. Transmitter Output Power is set on the "Configuration => Radio" page of a module.

Table 3 on page 13 shows SM settings and Table 4 on page 14 shows BH settings for different frequencies, along with associated ranges and 1X or 2X operation.

Transmitter Output Power on all hardware series of 5.4 GHz modules and on P10 hardware series of 5.2 and 5.7 GHz modules can be set in 1 dBm increments from 23 dBm down to the lowest the individual module will support, typically -2 dBm.

The LENS must *not* be used on P7, P8, or P9 hardware series 5.2 GHz modules as these modules do not allow a calibrated reduction in transmit power.

If **External Antenna Gain** is displayed on the "Configuration => Radio" page of a 5.4 GHz or 5.2 GHz module using a LENS, it should be set to 9 dB.

External Antenna Gain is a parameter that is only displayed for units operating with DFS (Dynamic Frequency Selection) for radar avoidance. Whether or not a module is using DFS is determined by frequency band, date of sale, and regulatory region as determined by the Region Code entered by the operator. The concept of a Region Code was introduced with the Release 8.2 software.

The External Antenna Gain parameter adjusts DFS sensitivity to radar. Being overly sensitive can cause false-positive DFS triggers from radar or radar-like signatures, with accompanying alternate frequency switch-over time or downtime.

The External Antenna Gain parameter *does not* change or affect transmitted power. Transmitted power is set directly by the Transmitter Output Power parameter.

6 Installation

The Canopy LENS simply snaps over the top end of a standard Canopy module. Built-in detents hold it securely on the module while allowing for easy removal.

The standard SMMB1 Canopy mounting bracket can be used to hold a Canopy module with a LENS. The LENS does increase weight and wind load slightly, so when either retrofitting an existing module with a LENS or installing a new module with a LENS confirm that the SMMB1 mounting bracket is securely attached to the building or structure.

The LENS *cannot* be used on P7, P8, or P9 hardware series 5.2 GHz modules in most regions, including the US and Canada, as these modules do not allow a calibrated reduction in transmit power needed to meet regulations in those regions.



IMPORTANT!

It is the responsibility of the operator and professional installer to ensure the LENS is installed and configured consistent with regulatory rules for their country or region.

Aim using standard aiming practices. In some cases it may be easier to aim first without the LENS, then add the LENS and fine-tune aim. If retrofitting an existing module with a LENS, confirm module aiming after attaching the LENS, as the 18° beam with the LENS may require more precise aiming than the 60° beam without the LENS.

Configuration of the Canopy module can be performed during or after installation, or pre-installation. In any case, see section 5 on page 12 for configuration information.

7 Regulatory and Legal Notices

7.1 IMPORTANT NOTE ON MODIFICATIONS

Intentional or unintentional changes or modifications to the equipment must not be made unless under the express consent of the party responsible for compliance. Any such modifications could void the user's authority to operate the equipment and will void the manufacturer's warranty.

7.2 NATIONAL AND REGIONAL REGULATORY NOTICES

7.2.1 U.S. Federal Communication Commission (FCC) Notification

This device complies with Part 15 of the US FCC Rules and Regulations. Operation is subject to the following two conditions: (1) This device may not cause harmful interference, and (2) This device must accept any interference received, including interference that may cause undesired operation.

This equipment has been tested and found to comply with the limits for a Class B digital device, pursuant to Part 15 of the US FCC Rules. These limits are designed to provide reasonable protection against harmful interference in a residential installation. This equipment generates, uses, and can radiate radio-frequency energy and, if not installed and used in accordance with these instructions, may cause harmful interference to radio communications. If this equipment does cause harmful interference to radio or television reception, which can be determined by turning the equipment on and off, the user is encouraged to correct the interference by one or more of the following measures:

- Increase the separation between the affected equipment and the unit;
- Connect the affected equipment to a power outlet on a different circuit from that which the receiver is connected to;
- Consult the dealer and/or experienced radio/TV technician for help.

FCC IDs and the specific configurations covered are listed in [Table 5](#).

Table 5: US FCC IDs and Industry Canada Certification Numbers and Covered Configurations

FCC ID	Industry Canada Cert Number	Frequencies	Module Families	Antenna, LENS, or Reflector	Maximum Transmitter Output Power
ABZ89FC3789	109W-5200	20 MHz channels, centered on 5275-5325 MHz in 5 MHz increments (within the 5250-5350 MHz U-NII band)	5200 BH, SM, AP	7 dBi internal	23 dBm (200 mW)
			5200 BH SM, AP, only P10 Modules	7 dBi internal + 18 dB reflector	5 dBm (3.2 mW)
				7 dBi internal + 9 dB lens	14 dBm (25 mW)
ABZ89FT7623	---	20 MHz channels, centered on 5495-5705 MHz in 5 MHz increments (within the 5470-5725 MHz U-NII band)	5400 BH, SM, AP	7 dBi internal	23 dBm (200 mW)
				7 dBi internal + 18 dB reflector	5 dBm (3.2 mW)
				7 dBi internal + 9 dB lens	14 dBm (25 mW)

FCC ID	Industry Canada Cert Number	Frequencies	Module Families	Antenna, LENS, or Reflector	Maximum Transmitter Output Power
---	109W-5400	20 MHz channels, centered on 5495-5575 and 5675-5705 MHz in 5 MHz increments (within the 5470-5725 MHz U-NII band with 5600-5650 MHz excluded)	5400 BH, SM, AP	7 dBi internal	23 dBm (200 mW)
				7 dBi internal + 18 di reflector	5 dBm (3.2 mW)
				7 dBi internal + 9 di lens	14 dBm (25 mW)
ABZ89FC5804	109W-5700	20 MHz channels, centered on 5735-5840 MHz in 5 MHz increments (within the 5725-5850 MHz ISM band)	5700 BH, SM, AP	7 dBi internal	23 dBm (200 mW)
			5700 BH, SM	7 dBi internal + 18 dB reflector	23 dBm (200 mW)
				7 dBi internal + 10 dB lens	23 dBm (200 mW)
			5700 AP	7 dBi internal + 10 dB lens	19 dBm (79 mW)

7.2.2 Industry Canada (IC) Notification

This device complies with RSS-210 of Industry Canada. Operation is subject to the following two conditions: (1) This device may not cause harmful interference, and (2) This device must accept any interference received, including interference that may cause undesired operation.

Users should be cautioned to take note that in Canada high power radars are allocated as primary users (meaning they have priority) of 5250 – 5350 MHz and 5650 – 5850 MHz and these radars could cause interference and/or damage to license-exempt local area networks (LELAN).

This equipment has been tested and found to comply with the limits for a Class B digital device, pursuant to RSS-210 of Industry Canada. These limits are designed to provide reasonable protection against harmful interference in a residential installation. This equipment generates, uses, and can radiate radio-frequency energy and, if not installed and used in accordance with these instructions, may cause harmful interference to radio communications. If this equipment does cause harmful interference to radio or television reception, which can be determined by turning the equipment on and off, the user is encouraged to correct the interference by one or more of the following measures:

- Increase the separation between the affected equipment and the unit;
- Connect the affected equipment to a power outlet on a different circuit from that which the receiver is connected to;
- Consult the dealer and/or experienced radio/TV technician for help.

To reduce potential radio interference to other users, the antenna type and its gain should be chosen so its Equivalent Isotropic Radiated Power (EIRP) is not more than that permitted for successful communication.

Industry Canada Certification Numbers and the specific configurations covered are listed in [Table 5](#).

This device has been designed to operate with the antennas listed in [Table 5](#) and having a maximum gain as shown in [Table 5](#). Antennas not included in [Table 5](#) or having a gain greater than as shown in [Table 5](#) are strictly prohibited from use with this device. Required antenna impedance is 50 ohms.

7.2.3 Regulatory Requirements for CEPT Member States (www.cept.org)

When operated in accordance with the instructions for use, Motorola Canopy Wireless equipment operating in the 5.4 GHz bands is compliant with CEPT Recommendation 70-03 Annex 3 for Wideband Data Transmission and HIPERLANs. For compliant operation in the 5.4 GHz band, the transmit power (EIRP) from the built-in patch antenna and any associated reflector dish shall be no more than 1 W (30 dBm).

For EU member states, RLAN equipment in the 5.4GHz bands is exempt from individual licensing under Commission Recommendation 2003/203/EC. Contact the appropriate national administrations for details on the conditions of use for the bands in question and any exceptions that might apply. Also see www.ero.dk for further information.

Motorola Canopy Radio equipment operating in the 5470 to 5725 MHz band are categorized as “Class 1” devices within the EU in accordance with ECC DEC(04)08 and are “CE” marked  to show compliance with the European Radio & Telecommunications Terminal Equipment (R&TTE) directive 1999/5/EC. The relevant Declaration of Conformity can be found at <http://motorola.canopywireless.com/doc.php>.

A European Commission decision, implemented by Member States on 31 October 2005, makes the frequency band 5470-5725 MHz available in all EU Member States for wireless access systems. Under this decision, the designation of Canopy 5.4GHz products become “Class 1 devices” and these do not require notification under article 6, section 4 of the R&TTE Directive.

Consequently, these 5.4GHz products are only marked with the  symbol and may be used in any member state.

For further details, see

http://europa.eu.int/information_society/policy/radio_spectrum/ref_documents/index_en.htm

7.2.4 European Union Notification for 5.7 GHz Product

The 5.7 GHz connectorized product is a two-way radio transceiver suitable for use in Broadband Wireless Access System (WAS), Radio Local Area Network (RLAN), or Fixed Wireless Access (FWA) systems. It is a Class 2 device and uses operating frequencies that are not harmonized throughout the EU member states. The operator is responsible for obtaining any national licenses required to operate this product and these must be obtained before using the product in any particular country.

This equipment is marked  0977 to show compliance with the European R&TTE directive 1999/5/EC.

The relevant Declaration of Conformity can be found at <http://www.canopywireless.com/doc.php>.

7.2.5 Equipment Disposal

**Waste (Disposal)
of Electronic
and Electric
Equipment**

Please do not dispose of Electronic and Electric Equipment or Electronic and Electric Accessories with your household waste. In some countries or regions, collection systems have been set up to handle waste of electrical and electronic equipment. In European Union countries, please contact your local equipment supplier representative or service center for information about the waste collection system in your country.

7.2.6 EU Declaration of Conformity for RoHS Compliance

Motorola hereby, declares that these Motorola products are in compliance with the essential requirements and other relevant provisions of Directive 2002/95/EC, Restriction of the use of certain Hazardous Substances (RoHS) in electrical and electronic equipment.

The relevant Declaration of Conformity can be found at <http://www.canopywireless.com/doc.php>.

7.2.7 Luxembourg Notification

5.4GHz products can only be used for mobile services.

7.2.8 Czech Republic Notification

5.4 GHz products can be operated in accordance with the Czech General License No. GL-30/R/2000.

7.2.9 Norway Notification

Use of the frequency bands 5725-5795 / 5815-5850 MHz are authorized with maximum radiated power of 4 W EIRP and maximum spectral power density of 200 mW/MHz. The radio equipment shall implement Dynamic Frequency Selection (DFS) as defined in Annex 1 of ITU-R Recommendation M.1652 / EN 301 893. Directional antennae with a gain up to 23 dBi may be used for fixed point-to-point links. The power flux density at the border between Norway and neighboring states shall not exceed – 122.5 dBW/m² measured with a reference bandwidth of 1 MHz.

Canopy 5.7 GHz connectorized products have been notified for use in Norway and are compliant when configured to meet the above National requirements. Users shall ensure that DFS functionality is enabled, maximum EIRP respected for a 20 MHz channel, and that channel spacings comply with the allocated frequency band to protect Road Transport and Traffic Telematics services (for example, 5735, 5755, 5775 or 5835 MHz are suitable carrier frequencies). Note that for directional fixed links, TPC is not required, conducted transmit power shall not exceed 30 dBm, and antenna gain is restricted to 23 dBi (maximum of 40W from the Canopy 5.7 GHz connectorized products).

7.2.10 Greece Notification

The outdoor use of 5470-5725MHz is under license of EETT but is being harmonized according to the CEPT Decision ECC/DEC/(04) 08, of 9th July. End users are advised to contact the EETT to determine the latest position and obtain any appropriate licenses.

7.2.11 Brazil Notification

Local regulations do not allow the use of 5.2 GHz Canopy modules in Brazil.

For compliant operation of an AP in the 5.7 GHz band, the Equivalent Isotropic Radiated Power from the built-in patch antenna and any associated reflector dish or LENS shall not exceed 36

dBm (4 W). When using the passive reflector (18 dB), transmitter output power must be configured no higher than 11 dBm. When using the LENS (10 dB at 5.7 GHz), transmitter output power must be configured no higher than 19 dBm.

For compliant operation in the 5.4 GHz band, the Equivalent Isotropic Radiated Power from the built-in patch antenna and any associated reflector dish or LENS shall not exceed 30 dBm (1 W). When using the passive reflector (18 dB), transmitter output power must be configured no higher than 5 dBm. When using the LENS (9 dB at 5.4 GHz), transmitter output power must be configured no higher than 14 dBm. When not using the passive reflector or the LENS, the transmitter output power of the radio must be configured no higher than 23 dBm.

The operator is responsible for enabling the DFS feature on any Canopy 5.4 GHz radio by setting the Region Code to "Brazil", including after the module is reset to factory defaults.

Important Note: This equipment operates as a secondary application, so it has no rights against harmful interference, even if generated by similar equipment, and cannot cause harmful interference on systems operating as primary applications.

7.2.12 Labeling and Disclosure Table for China

The People's Republic of China requires that Motorola's products comply with China Management Methods (CMM) environmental regulations. (China Management Methods refers to the regulation *Management Methods for Controlling Pollution by Electronic Information Products*.) Two items are used to demonstrate compliance; the label and the disclosure table.

The label is placed in a customer visible position on the product.

- Logo 1 means that the product contains no substances in excess of the maximum concentration value for materials identified in the China Management Methods regulation.
- Logo 2 means that the product may contain substances in excess of the maximum concentration value for materials identified in the China Management Methods regulation, and has an Environmental Friendly Use Period (EFUP) in years, fifty years in the example shown.

Logo 1



Logo 2



The Environmental Friendly Use Period (EFUP) is the period (in years) during which the Toxic and Hazardous Substances (T&HS) contained in the Electronic Information Product (EIP) will not leak or mutate causing environmental pollution or bodily injury from the use of the EIP. The EFUP indicated by the Logo 2 label applies to a product and all its parts. Certain field-replaceable parts, such as battery modules, can have a different EFUP and are marked separately.

The Disclosure Table is intended only to communicate compliance with China requirements; it is not intended to communicate compliance with EU RoHS or any other environmental requirements.

部件名称	有毒有害物质或元素					
	铅 (Pb)	汞 (Hg)	镉 (Cd)	六价铬 (Cr ⁶⁺)	多溴联苯 (PBB)	多溴二苯醚 (PBDE)
金属部件	×	○	×	×	○	○
电路模块	×	○	×	×	○	○
电缆及电缆组件	×	○	×	×	○	○
塑料和聚合物部件	○	○	○	○	○	×

○： 表示该有毒有害物质在该部件所有均质材料中的含量均在SJ/T11363-2006 标准规定的限量要求以下。
 ×： 表示该有毒有害物质至少在该部件的某一均质材料中的含量超出SJ/T11363-2006 标准规定的限量要求。

Table 6: Disclosure Table

7.3 EXPOSURE SEPARATION DISTANCES

To protect from overexposure to RF energy, install Canopy radios so as to provide and maintain the minimum separation distances from all persons shown in Table 7.

Table 7: Exposure Separation Distances

Module Type	Separation Distance from Persons
Canopy Module	At least 20 cm (approx 8 in)
Canopy Module with Reflector Dish	At least 1.5 m (approx 60 in or 5 ft)
Canopy Module with LENS	At least 0.5 m (approx 20 in)
Antenna of connectorized 5.7 GHz AP	At least 30 cm (approx 12 in)

Section 7.3.1 and Table 8 give details and discussion of the associated calculations.

7.3.1 Details of Exposure Separation Distances Calculations and Power Compliance Margins

Limits and guidelines for RF exposure come from:

- US FCC limits for the general population. See the FCC web site at <http://www.fcc.gov>, and the policies, guidelines, and requirements in Part 1 of Title 47 of the Code of Federal Regulations, as well as the guidelines and suggestions for evaluating compliance in FCC OET Bulletin 65.
- Health Canada limits for the general population. See the Health Canada web site at <http://www.hc-sc.gc.ca/rpb> and Safety Code 6.

- ICNIRP (International Commission on Non-Ionizing Radiation Protection) guidelines for the general public. See the ICNIRP web site at <http://www.icnirp.de/> and Guidelines for Limiting Exposure to Time-Varying Electric, Magnetic, and Electromagnetic Fields.

The applicable power density exposure limits from the documents referenced above are

- 6 W/m² for RF energy in the 900-MHz frequency band in the US and Canada.
- 10 W/m² for RF energy in the 2.4-, 5.2-, 5.4-, and 5.7-GHz frequency bands.

Peak power density in the far field of a radio frequency point source is calculated as follows:

$$S = \frac{P \cdot G}{4 \pi d^2}$$

where
 S = power density in W/m²
 P = RMS transmit power capability of the radio, in W
 G = total Tx gain as a factor, converted from dB
 d = distance from point source, in m

Rearranging terms to solve for distance yields

$$d = \sqrt{\frac{P \cdot G}{4 \pi S}}$$

Table 8 shows calculated minimum separation distances *d*, recommended distances and resulting power compliance margins for each frequency band and antenna combination.

Table 8: Calculated Exposure Distances and Power Compliance Margins

Frequency Band	Antenna	Variable			<i>d</i> (calculated)	Recommended Separation Distance	Power Compliance Margin
		<i>P</i>	<i>G</i>	<i>S</i>			
5.2 GHz	integrated	0.2 W (23 dBm)	5.0 (7 dB)	10 W/m ²	9 cm	20 cm (8 in)	5
	integrated plus reflector	0.0032 W (5 dBm)	316 (25 dB)	10 W/m ²	9 cm	1.5 m (5 ft)	279
	integrated plus LENS	0.025 W (14 dBm)	40 (16 dB)	10 W/m ²	9 cm	50 cm (12 in)	31
5.4 GHz	integrated	0.2 W (23 dBm)	5.0 (7 dB)	10 W/m ²	9 cm	20 cm (8 in)	5
	integrated plus reflector	0.0032 W (5 dBm)	316 (25 dB)	10 W/m ²	9 cm	1.5 m (5 ft)	279
	integrated plus LENS	0.020 W (13 dBm)	50 (17 dB)	10 W/m ²	9 cm	50 cm (12 in)	31

Frequency Band	Antenna	Variable			d (calculated)	Recommended Separation Distance	Power Compliance Margin
		P	G	S			
5.7 GHz	integrated	0.2 W (23 dBm)	5.0 (7 dB)	10 W/m ²	9 cm	20 cm (8 in)	5
	integrated plus reflector	0.2 W (23 dBm)	316 (25 dB)	10 W/m ²	71 cm	1.5 m (5 ft)	4.5
	Integrated plus LENS	0.2 W (23 dBm)	50 (17 dB)	1 W/m ²	28 cm	50 cm (12 in)	3.13

The "Recommended Distances" are chosen to give significant compliance margin in all cases. They are also chosen so that a given item (bare module, reflector, or LENS) always has the same distance, regardless of frequency band, to simplify following exposure distances in the field.

These are conservative distances:

- They are along the beam direction (the direction of greatest energy). Exposure to the sides and back of the module will be significantly less.
- They meet sustained exposure limits for the general population (not just short term occupational exposure limits), with considerable margin.

In the reflector cases, the calculated compliance distance d is greatly overestimated because the far-field equation models the reflector as a point source and neglects the physical dimension of the reflector.

7.4 LEGAL NOTICES

7.4.1 Software License Terms and Conditions

ONLY OPEN THE PACKAGE, OR USE THE SOFTWARE AND RELATED PRODUCT IF YOU ACCEPT THE TERMS OF THIS LICENSE. BY BREAKING THE SEAL ON THIS DISK KIT / CDROM, OR IF YOU USE THE SOFTWARE OR RELATED PRODUCT, YOU ACCEPT THE TERMS OF THIS LICENSE AGREEMENT. IF YOU DO NOT AGREE TO THESE TERMS, DO NOT USE THE SOFTWARE OR RELATED PRODUCT; INSTEAD, RETURN THE SOFTWARE TO PLACE OF PURCHASE FOR A FULL REFUND. THE FOLLOWING AGREEMENT IS A LEGAL AGREEMENT BETWEEN YOU (EITHER AN INDIVIDUAL OR ENTITY), AND MOTOROLA, INC. (FOR ITSELF AND ITS LICENSORS). THE RIGHT TO USE THIS PRODUCT IS LICENSED ONLY ON THE CONDITION THAT YOU AGREE TO THE FOLLOWING TERMS.

Now, therefore, in consideration of the promises and mutual obligations contained herein, and for other good and valuable consideration, the receipt and sufficiency of which are hereby mutually acknowledged, you and Motorola agree as follows:

Grant of License. Subject to the following terms and conditions, Motorola, Inc., grants to you a personal, revocable, non-assignable, non-transferable, non-exclusive and limited license to use on a single piece of equipment only one copy of the software contained on this disk (which may have been pre-loaded on the equipment)(Software). You may make two copies of the Software, but only for backup, archival, or disaster recovery purposes. On any copy you make of the Software, you must reproduce and include the copyright and other proprietary rights notice contained on the copy we have furnished you of the Software.

Ownership. Motorola (or its supplier) retains all title, ownership and intellectual property rights to the Software and any copies,

including translations, compilations, derivative works (including images) partial copies and portions of updated works. The Software is Motorola's (or its supplier's) confidential proprietary information. This Software License Agreement does not convey to you any interest in or to the Software, but only a limited right of use. You agree not to disclose it or make it available to anyone without Motorola's written authorization. You will exercise no less than reasonable care to protect the Software from unauthorized disclosure. You agree not to disassemble, decompile or reverse engineer, or create derivative works of the Software, except and only to the extent that such activity is expressly permitted by applicable law.

Termination. This License is effective until terminated. This License will terminate immediately without notice from Motorola or judicial resolution if you fail to comply with any provision of this License. Upon such termination you must destroy the Software, all accompanying written materials and all copies thereof, and the sections entitled Limited Warranty, Limitation of Remedies and Damages, and General will survive any termination.

Limited Warranty. Motorola warrants for a period of ninety (90) days from Motorola's or its customer's shipment of the Software to you that (i) the disk(s) on which the Software is recorded will be free from defects in materials and workmanship under normal use and (ii) the Software, under normal use, will perform substantially in accordance with Motorola's published specifications for that release level of the Software. The written materials are provided "AS IS" and without warranty of any kind. Motorola's entire liability and your sole and exclusive remedy for any breach of the foregoing limited warranty will be, at Motorola's option, replacement of the disk(s), provision of downloadable patch or replacement code, or refund of the unused portion of your bargained for contractual benefit up to the amount paid for this Software License.

THIS LIMITED WARRANTY IS THE ONLY WARRANTY PROVIDED BY MOTOROLA, AND MOTOROLA AND ITS LICENSORS EXPRESSLY DISCLAIM ALL OTHER WARRANTIES, EITHER EXPRESS OF IMPLIED, INCLUDING BUT NOT LIMITED TO IMPLIED WARRANTIES OF MERCHANTABILITY AND FITNESS FOR A PARTICULAR PURPOSE AND NONINFRINGEMENT. MOTOROLA DOES NOT WARRANT THAT THE OPERATION OF THE SOFTWARE WILL BE UNINTERRUPTED OR ERROR-FREE, OR THAT DEFECTS IN THE SOFTWARE WILL BE CORRECTED. NO ORAL OR WRITTEN REPRESENTATIONS MADE BY MOTOROLA OR AN AGENT THEREOF SHALL CREATE A WARRANTY OR IN ANY WAY INCREASE THE SCOPE OF THIS WARRANTY. MOTOROLA DOES NOT WARRANT ANY SOFTWARE THAT HAS BEEN OPERATED IN EXCESS OF SPECIFICATIONS, DAMAGED, MISUSED, NEGLECTED, OR IMPROPERLY INSTALLED. BECAUSE SOME JURISDICTIONS DO NOT ALLOW THE EXCLUSION OR LIMITATION OF IMPLIED WARRANTIES, THE ABOVE LIMITATIONS MAY NOT APPLY TO YOU.

Limitation of Remedies and Damages. Regardless of whether any remedy set forth herein fails of its essential purpose, IN NO EVENT SHALL MOTOROLA OR ANY OF THE LICENSORS, DIRECTORS, OFFICERS, EMPLOYEES OR AFFILIATES OF THE FOREGOING BE LIABLE TO YOU FOR ANY CONSEQUENTIAL, INCIDENTAL, INDIRECT, SPECIAL OR SIMILAR DAMAGES WHATSOEVER (including, without limitation, damages for loss of business profits, business interruption, loss of business information and the like), whether foreseeable or unforeseeable, arising out of the use or inability to use the Software or accompanying written materials, regardless of the basis of the claim and even if Motorola or a Motorola representative has been advised of the possibility of such damage. Motorola's liability to you for direct damages for any cause whatsoever, regardless of the basis of the form of the action, will be limited to the price paid for the Software that caused the damages. THIS LIMITATION WILL NOT APPLY IN CASE OF PERSONAL INJURY ONLY WHERE AND TO THE EXTENT THAT APPLICABLE LAW REQUIRES SUCH LIABILITY. BECAUSE SOME JURISDICTIONS DO NOT ALLOW THE

EXCLUSION OR LIMITATION OF LIABILITY FOR CONSEQUENTIAL OR INCIDENTAL DAMAGES, THE ABOVE LIMITATION MAY NOT APPLY TO YOU.

Maintenance and Support. Motorola shall not be responsible for maintenance or support of the software. By accepting the license granted under this agreement, you agree that Motorola will be under no obligation to provide any support, maintenance or service in connection with the Software or any application developed by you. Any maintenance and support of the Related Product will be provided under the terms of the agreement for the Related Product.

Transfer. In the case of software designed to operate on Motorola equipment, you may not transfer the Software to another party except: (1) if you are an end-user, when you are transferring the Software together with the Motorola equipment on which it operates; or 2) if you are a Motorola licensed distributor, when you are transferring the Software either together with such Motorola equipment or are transferring the Software as a licensed duly paid for upgrade, update, patch, new release, enhancement or replacement of a prior version of the Software. If you are a Motorola licensed distributor, when you are transferring the Software as permitted herein, you agree to transfer the Software with a license agreement having terms and conditions no less restrictive than those contained herein. You may transfer all other Software, not otherwise having an agreed restriction on transfer, to another party. However, all such transfers of Software are strictly subject to the conditions precedent that the other party agrees to accept the terms and conditions of this License, and you destroy any copy of the Software you do not transfer to that party. You may not sublicense or otherwise transfer, rent or lease the Software without our written consent. You may not transfer the Software in violation of any laws, regulations, export controls or economic sanctions imposed by the US Government.

Right to Audit. Motorola shall have the right to audit annually, upon reasonable advance notice and during normal business hours, your records and accounts to determine compliance with the terms of this Agreement.

Export Controls. You specifically acknowledge that the software may be subject to United States and other country export control laws. You shall comply strictly with all requirements of all applicable export control laws and regulations with respect to all such software and materials.

US Government Users. If you are a US Government user, then the Software is provided with "RESTRICTED RIGHTS" as set forth in subparagraphs (c)(1) and (2) of the Commercial Computer Software-Restricted Rights clause at FAR 52 227-19 or subparagraph (c)(1)(ii) of the Rights in Technical Data and Computer Software clause at DFARS 252.227-7013, as applicable.

Disputes. You and Motorola hereby agree that any dispute, controversy or claim, except for any dispute, controversy or claim involving intellectual property, prior to initiation of any formal legal process, will be submitted for non-binding mediation, prior to initiation of any formal legal process. Cost of mediation will be shared equally. Nothing in this Section will prevent either party from resorting to judicial proceedings, if (i) good faith efforts to resolve the dispute under these procedures have been unsuccessful, (ii) the dispute, claim or controversy involves intellectual property, or (iii) interim relief from a court is necessary to prevent serious and irreparable injury to that party or to others.

General. Illinois law governs this license. The terms of this license are supplemental to any written agreement executed by both parties regarding this subject and the Software Motorola is to license you under it, and supersedes all previous oral or written communications between us regarding the subject except for such executed agreement. It may not be modified or waived except in writing and signed by an officer or other authorized representative of each party. If any provision is held invalid, all other provisions shall remain valid, unless such invalidity would frustrate the purpose of our agreement. The failure of either party to enforce any rights granted hereunder or to take action against the other party in the event of any breach hereunder shall not

be deemed a waiver by that party as to subsequent enforcement of rights or subsequent action in the event of future breaches.

7.4.2 Hardware Warranty in US

Motorola US offers a warranty covering a period of 1 year from the date of purchase by the customer. If a product is found defective during the warranty period, Motorola will repair or replace the product with the same or a similar model, which may be a reconditioned unit, without charge for parts or labor.

7.5 LIMIT OF LIABILITY

IN NO EVENT SHALL MOTOROLA BE LIABLE TO YOU OR ANY OTHER PARTY FOR ANY DIRECT, INDIRECT, GENERAL, SPECIAL, INCIDENTAL, CONSEQUENTIAL, EXEMPLARY OR OTHER DAMAGE ARISING OUT OF THE USE OR INABILITY TO USE THE PRODUCT (INCLUDING, WITHOUT LIMITATION, DAMAGES FOR LOSS OF BUSINESS PROFITS, BUSINESS INTERRUPTION, LOSS OF BUSINESS INFORMATION OR ANY OTHER PECUNIARY LOSS, OR FROM ANY BREACH OF WARRANTY, EVEN IF MOTOROLA HAS BEEN ADVISED OF THE POSSIBILITY OF SUCH DAMAGES. (Some states do not allow the exclusion or limitation of incidental or consequential damages, so the above exclusion or limitation may not apply to you.) IN NO CASE SHALL MOTOROLA'S LIABILITY EXCEED THE AMOUNT YOU PAID FOR THE PRODUCT.