

# *Installation Manual* **MARINE RADAR**

*Model FAR-1513/1523/1513-BB/1523-BB/  
FAR-1518/1528/1518-BB/1528-BB*

---

<b>SAFETY INSTRUCTIONS .....</b>	<b>i</b>
<b>SYSTEM CONFIGURATION .....</b>	<b>iii</b>
<b>EQUIPMENT LIST .....</b>	<b>v</b>
<b>1. INSTALLATION .....</b>	<b>1-1</b>
1.1 Before Beginning the Installation.....	1-1
1.2 Antenna Unit Installation Considerations .....	1-2
1.3 How to Install the Antenna Unit for FAR-1513, FAR-1523.....	1-3
1.4 How to Install the Antenna Unit for FAR-1518, FAR-1528.....	1-8
1.5 Processor Unit .....	1-10
1.6 Display Unit.....	1-11
1.7 Control Unit.....	1-11
1.8 Trackball Control Unit (option).....	1-12
<b>2. WIRING.....</b>	<b>2-1</b>
2.1 Wiring Outline .....	2-1
2.2 How to Connect the Signal Cable for FAR-1513, FAR-1523.....	2-2
2.3 How to Connect the Signal Cable for FAR-1518, FAR-1528.....	2-6
2.4 Processor Unit .....	2-10
2.5 Trackball Control Unit .....	2-17
2.6 VDR Connection .....	2-18
2.7 Shuttle Ferry Mode .....	2-18
<b>3. ADJUSTMENTS .....</b>	<b>3-1</b>
3.1 How to Open the Radar Installation Menu .....	3-1
3.2 How to Use the Menu .....	3-2
3.3 How to Initialize Tuning.....	3-2
3.4 How to Align the Heading .....	3-3
3.5 How to Adjust Sweep Timing.....	3-4
3.6 How to Suppress Main Bang .....	3-4
3.7 RADAR INSTALLATION Menu.....	3-5
3.8 Display Unit Setting.....	3-14
<b>4. INPUT/OUTPUT DATA.....</b>	<b>4-1</b>
4.1 Processor Unit .....	4-1
4.2 IEC 61162 Sentences .....	4-2
<b>APPENDIX 1 JIS CABLE GUIDE .....</b>	<b>AP-1</b>
<b>APPENDIX 2 DIGITAL INTERFACE .....</b>	<b>AP-2</b>
<b>PACKING LISTS .....</b>	<b>A-1</b>
<b>OUTLINE DRAWINGS .....</b>	<b>D-1</b>
<b>INTERCONNECTION DIAGRAMS.....</b>	<b>S-1</b>



**FURUNO ELECTRIC CO., LTD.**

[www.furuno.com](http://www.furuno.com)

All brand and product names are trademarks, registered trademarks or service marks of their respective holders.

**ECF**

(Elemental Chlorine Free)

The paper used in this manual  
is elemental chlorine free.

**FURUNO ELECTRIC CO., LTD.**

9-52 Ashihara-cho,  
Nishinomiya, 662-8580, JAPAN

• FURUNO Authorized Distributor/Dealer

All rights reserved. Printed in Japan

Pub. No. IME-36380-B4

(TEHI ) FAR-15x3/15x8/BB

A : NOV. 2015

B4 : MAR. 29, 2017





0 0 0 1 9 0 8 3 5 1 1





# SAFETY INSTRUCTIONS

The installer of the equipment must read these safety instructions before attempting to install the equipment.

 <b>DANGER</b>	Indicates a potentially hazardous situation which, if not avoided, will result in death or serious injury.
 <b>WARNING</b>	Indicates a potentially hazardous situation which, if not avoided, could result in death or serious injury.
 <b>CAUTION</b>	Indicates a potentially hazardous situation which, if not avoided, can result in minor or moderate injury.

 Warning, Caution	 Prohibitive Action	 Mandatory Action
--	--	--

** DANGER**



**Wear a safety belt and hard hat when working on the antenna unit.**  
Serious injury or death can result if someone falls from the radar antenna mast.

## **WARNING**



### Radio Frequency Radiation Hazard

The radar antenna emits electromagnetic radio frequency (RF) energy which can be harmful, particularly to your eyes. Never look directly into the antenna aperture from a close distance while the radar is in operation or expose yourself to the transmitting antenna at a close distance. Distances at which RF radiation level of 100 W/m<sup>2</sup>, 50 W/m<sup>2</sup> and 10 W/m<sup>2</sup> are given in the table below.

If the antenna unit is installed at a close distance in front of the wheel house, your administration may require halt of transmission within a certain sector of antenna revolution. See the installation manual for how to manage blind sectors.

Radar model	Transceiver	Magnetron	Antenna	100W/m <sup>2</sup>	50W/m <sup>2</sup>	10W/m <sup>2</sup>
FAR-1513	RTR-086A	MAF1565N	XN12A	N/A		2.1 m
			XN13A	N/A		1.9 m
FAR-1523	RTR-087A	M1458F	XN12A	0.6 m		4.6 m
			XN13A	0.4 m		3.1 m
FAR-1518	RTR-100	MAF1615B	XN12AF	0.3 m	0.7 m	4.1 m
			XN20AF	0.2 m	0.5 m	3.1 m
FAR-1528	RTR-101	MG5436	XN20AF	0.6 m	1.2 m	6.1 m
			XN24AF	0.3 m	0.8 m	4.0 m

**WARNING**

**ELECTRICAL SHOCK HAZARD**

**Do not open the equipment unless totally familiar with electrical circuits and service manual.**

Only qualified personnel are allowed to work inside the equipment.

**Construct a suitable service platform from which to install the antenna unit.**

Serious injury or death can result if someone falls from the radar antenna mast.

**Turn off the power at the mains switchboard before beginning the installation.**

Fire, electrical shock or serious injury can result if the power is left on or is applied while the equipment is being installed.

**Be sure that the power supply is compatible with the voltage rating of the equipment.**

Connection of an incorrect power supply can cause fire or damage the equipment.

**Use only the specified power cable.**

Fire or damage to the equipment can result if a different cable is used.

**Do not install the processor unit, display unit or a control unit in a dusty environment, or a location where the units may get wet from rain or water splash.**

Foreign material or water in the units can result in fire, electrical shock, or damage to the equipment.

**Connect protective earth between the processor unit and the ship's superstructure.**

The protective earth (grounding) is required for the AC power supply to prevent electrical shock.

**CAUTION**

**Observe the following compass safe distances to prevent interference to a magnetic compass:**

Unit		Standard compass	Steering compass
Antenna Unit for FAR-1513	RSB-0070	1.00 m	0.60 m
	RSB-0073	1.10 m	0.70 m
Antenna Unit for FAR-1523	RSB-0070	1.85 m	1.25 m
	RSB-0073	1.80 m	1.15 m
Antenna Unit for FAR-1518	RSB-120	1.55 m	1.00 m
	RSB-121		
Antenna Unit for FAR-1528	RSB-120	2.05 m	1.30 m
	RSB-121		
Processor Unit (RPU-024)		2.60 m	1.70 m
Control Unit (RCU-028)		0.90 m	0.60 m
Display Unit (MU-150HD)		0.65 m	0.45 m
Display Unit (MU-190)		1.65 m	1.05 m
Trackball Control Unit (RCU-030)		0.50 m	0.30 m

**Note:** For more information, please refer to IMO SN/Circ.271 "Guidelines for the installation of shipborne radar equipment."

# SYSTEM CONFIGURATION

## FAR-1513(-BB), FAR-1523(-BB)

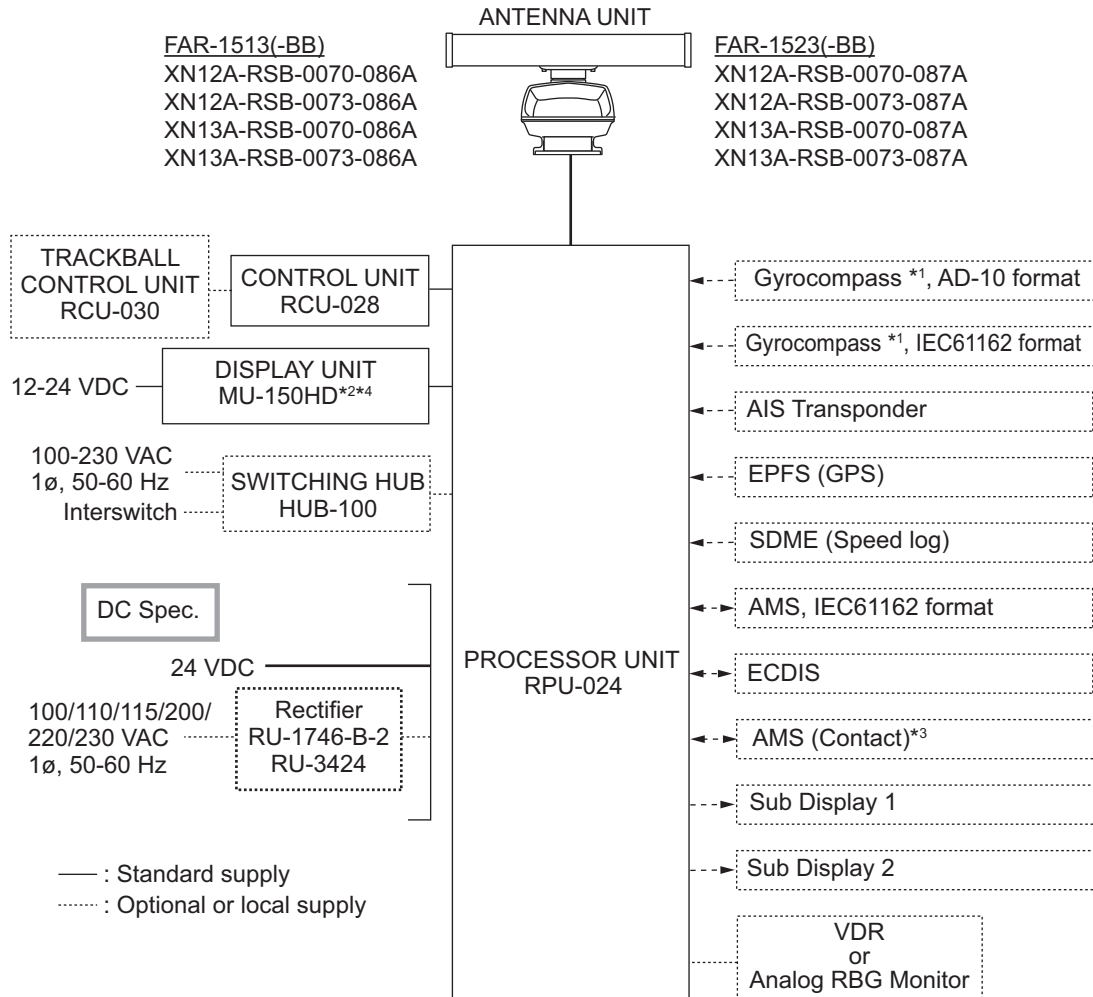

### Equipment category

Unit	Category
Antenna	Exposed to the weather
Other units	Protected from the weather

\*1: The gyrocompass must also have an update rate that is adequate for the ship's rate of turn. The update rate must be better than 40 Hz (HSC) or 20 Hz (conventional vessel).

\*2: This monitor has been approved by the IMO, MU-150HD for CAT 3. If a different monitor is to be used on IMO vessels, its effective diameter must meet the applicable Category requirements (CAT 3: Effective diameter 180 mm or higher). For installation, operation and viewing distance of other monitors, see their respective manuals. For BB types, a monitor is to be prepared by the user.

\*3: Characteristics of contact output for AMS (Alert Management System):

- (Load current) 250 mA
- (Polarity) Normally Open: 2 ports, Normally Close: 2 ports

\*4: Standard supply with FAR-1513/FAR-1523 only.

**FAR-1518(-BB), FAR-1528(-BB)**

**NOTICE FOR FAR-1518(-BB)/FAR-1528(-BB)**

The radar(s) must be interconnected to the following type approved sensors:

- Gyrocompass meeting requirements of the IMO resolution A.424(XI).
- EPFS meeting the requirements of the IMO resolution MSC.112(73).
- SDME meeting the requirements of the IMO resolution MSC.96(72).

The radar may be interconnected via HUB-100 to other FURUNO processing units having approved LAN ports.

The following sentences cannot be used for installations on SOLAS vessels: BWC, BWR, DBK, GBS, HDG, HDM and TLL.

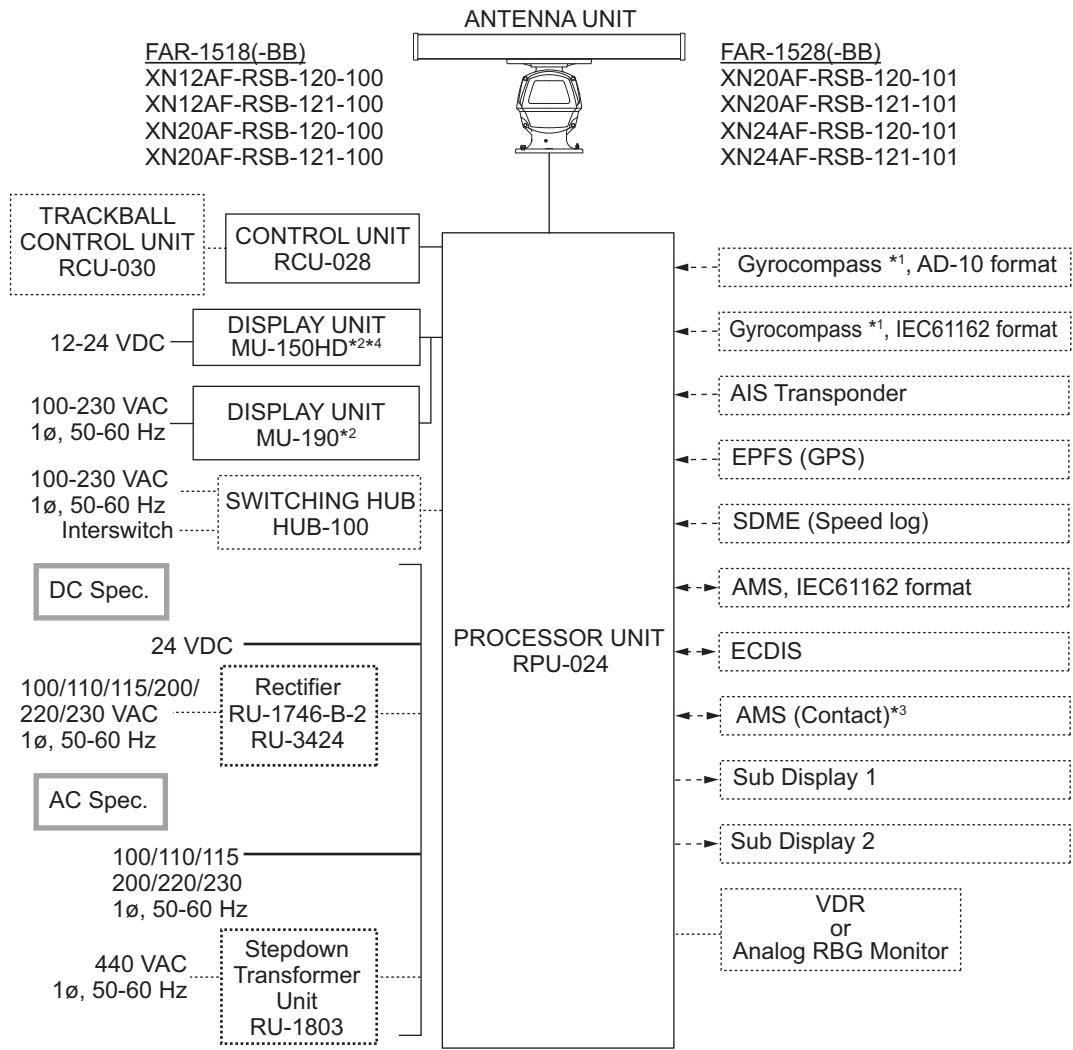

Equipment category

Unit	Category
Antenna	Exposed to the weather
Other units	Protected from the weather

— : Standard supply  
 ..... : Optional or local supply

**\*1:** The gyrocompass must also have an update rate that is adequate for the ship's rate of turn. The update rate must be better than 40 Hz (HSC) or 20 Hz (conventional vessel).

**\*2:** This monitor has been approved by the IMO, MU-150HD for CAT 3, MU-190 for CAT-2. If a different monitor is to be used on IMO vessels, its effective diameter must meet the applicable Category requirements (CAT 3: Effective diameter 180 mm or higher; CAT 2: Effective diameter 250 mm or higher). For installation, operation and viewing distance of other monitors, see their respective manuals. For BB types, a monitor is to be prepared by the user.

**\*3:** Characteristics of contact output for AMS (Alert Management System):

- (Load current) 250 mA
- (Polarity) Normally Open: 2 ports, Normally Close: 2 ports

**\*4:** Standard supply with FAR-1518/FAR-1528 only.

# EQUIPMENT LIST

## Standard supply

Name	Type	Code No.	Qty	Remarks
Processor Unit	RPU-024	-	1	
Control Unit	RCU-028	-	1	
Display Unit	MU-150HD	-	Select one	
	MU-190	-		
Antenna Unit (FAR-1513, FAR-1513-BB)	XN12A-RSB-0070-086A	-	Select one	24 rpm, 1200 mm
	XN12A-RSB-0073-086A	-		48 rpm, 1200 mm
	XN13A-RSB-0070-086A	-		24 rpm, 1800 mm
	XN13A-RSB-0073-086A	-		48 rpm, 1800 mm
Antenna Unit (FAR-1523, FAR-1523-BB)	XN12A-RSB-0070-087A	-	Select one	24 rpm, 1200 mm
	XN12A-RSB-0073-087A	-		48 rpm, 1200 mm
	XN13A-RSB-0070-087A	-		24 rpm, 1800 mm
	XN13A-RSB-0073-087A	-		48 rpm, 1800 mm
Antenna Unit FAR-1518, FAR-1518-BB)	XN12AF-RSB-120-100	-	Select one	26 rpm, 1200 mm
	XN12AF-RSB-121-100	-		48 rpm, 1200 mm
	XN20AF-RSB-120-100	-		26 rpm, 2000 mm
	XN20AF-RSB-121-100	-		48 rpm, 2000 mm
Antenna Unit (FAR-1528, FAR-1528-BB)	XN20AF-RSB-120-101	-	Select one	26 rpm, 2000 mm
	XN20AF-RSB-121-101	-		48 rpm, 2000 mm
	XN24AF-RSB-120-101	-		26 rpm, 2400 mm
	XN24AF-RSB-121-101	-		48 rpm, 2400 mm
Installation Materials (FAR-1513, FAR-1513-BB)	CP03-36700	000-028-129	Select one	10 m signal cable
	CP03-36710	000-028-130		15 m signal cable
	CP03-36720	000-028-131		20 m signal cable
	CP03-36730	000-028-132		30 m signal cable
Installation Materials (FAR-1523, FAR-1523-BB)	CP03-36800	000-028-133	Select one	10 m signal cable
	CP03-36810	000-028-134		15 m signal cable
	CP03-36820	000-028-135		20 m signal cable
	CP03-36830	000-028-136		30 m signal cable
Installation Materials (FAR-1518, FAR-1518-BB FAR-1528, FAR-1528-BB)	CP03-36900	000-028-137	Select one	15 m signal cable
	CP03-36910	000-028-138		20 m signal cable
	CP03-36920	000-028-139		30 m signal cable
Installation Materials	CP03-36500	000-027-862	1	For processor unit, includes CP03-36501, DVI-D/D S-LINK (5m)
Installation Materials	CP03-36510	000-028-881	1	For control unit/processor unit, includes CP03-36501, CP03-36601, DVI-D/D S-LINK (5m)
Spare Parts	SP03-18001	001-419-820	1	Fuses (2 pcs.), for DC power processor unit
Spare Parts	SP03-18002	001-419-830	1	Fuses (2 pcs.), for AC power processor unit

## EQUIPMENT LIST

**Optional supply**

Name	Type	Code No.	Remarks
Control Unit	RCU-028	-	
Performance Monitor	PM-32A	001-419-490	Mandatory for IMO radars.
Processor Unit IPX2 Kit	OP03-238	001-419-560	
Stepdown Transformer Unit	RU-1803	-	440 V→100 V
Rectifier	RU-3423	-	For display unit, current capacity max. 7A
	PR-240	-	For display unit, current capacity max. 8A
	RU-1746B-2	-	Current capacity max. 13A
	RU-3424	-	Current capacity max. 20A
	PR-850A	-	100/110/120/220/240 VAC→24 VDC. Current capacity max. 30A
Cable Assy.	RW-4864 1M	001-103-620-10	Radar signal cable, 1 m
	RW-4864 5M	001-103-630-10	Radar signal cable, 5 m
	RW-4864 10M	001-103-640-10	Radar signal cable, 10 m
	RW-4864 15M	001-103-650-10	Radar signal cable, 15 m
Cable Assy.	DVI-D/D S-LINK 10M	001-133-980-10	For Display Unit, DVI cable, 10 m
Switching Hub	HUB-100	-	
Installation Materials	CP03-28900	000-082-658	10 m
Installation Materials	CP03-28910	000-082-659	20 m
Installation Materials	CP03-28920	000-082-660	30 m
Flush Mount Kit	OP26-4	001-080-850	
Hood Assy.	OP26-3	001-080-840	
Bracket Assy.	OP26-2	000-016-268	
LAN Cable	MOD-Z072-020+	001-167-880-10	
	MOD-Z072-050+	001-167-890-10	
	MOD-Z072-100+	001-167-900-10	
Cable Assy.	3COX-2P-6C 5M	001-077-230-10	
	3COX-2P-6C 10M	001-077-220-10	

**Local supply**

Name	Type	Code No.	Remarks
Display Unit	MU-190	-	For -BB configurations.

# 1. INSTALLATION

## 1.1 Before Beginning the Installation...

Please read the instructions below before beginning the installation.

- Do the installation following the instructions contained in this manual.
- Be sure to do the installation setup (tuning, timing, heading alignment, etc.) in chapter 3 after installing the equipment.
- The cable names mentioned throughout this manual are JIS (Japan Industrial Standard) cables. If not available locally, see Appendix 1 for the equivalent cables.
- The control unit cannot be mounted in a console - it is designed to be mounted on a desktop.
- See the table below for retrofit possibility. The existing antenna cable for the FR-8125 or FR-8255 can be used, by attaching a connector (NH and VH). However, replacement of the cable is recommended.

	Retrofit possibility		
	FAR-1513/1523	FAR-1518/1528 (no Performance Monitor)	FAR-1518/1528 (w/Performance Monitor)
FR-8002 series	Yes	No	No
FR-1500 MK3 series	Yes	Yes	No

- The antenna cable for the FAR-1513/FAR-1523 has connectors at both its ends. If the cable is to be passed through a bulkhead, do not remove the connectors (to make it easier to pass the cable through the bulkhead). Make an opening in the bulkhead large enough to pass the cable and the connectors.
- Use only the specified power cable and fuse.
- Connect the DC power specification processor unit to the ship's mains via a breaker.
- Ground the AC power specification processor unit.
- If the processor unit is to be installed near where water or rain splash may occur, install the optional waterproofing kit, which waterproofs the unit to waterproofing standard IPX2. Do not install the unit in an area where water or rain splash exceeds the conditions of IPX2.
- Do not connect the radar to the ship's onboard LAN.
- Connect the drain wires of external equipment to the specified locations in the processor unit to prevent noise.
- Do not disassemble the equipment, to prevent electrical shock.
- Do not apply paint, anti-corrosive sealant or contact spray to exterior surfaces or plastic parts of the equipment. Those items contain organic solvents that can damage coating and plastic parts, especially plastic connectors.
- In case of trouble consult with a FURUNO dealer.
- The "BB" (BlackBox, monitor unit supplied locally) model is not included in section titles or descriptions unless necessary, since the configuration is the same otherwise.

## 1.2 Antenna Unit Installation Considerations

- The antenna unit is generally installed either on top of the wheelhouse or on the radar mast, on a suitable platform. Locate the antenna unit in an elevated position not interfered by any shipboard structure.

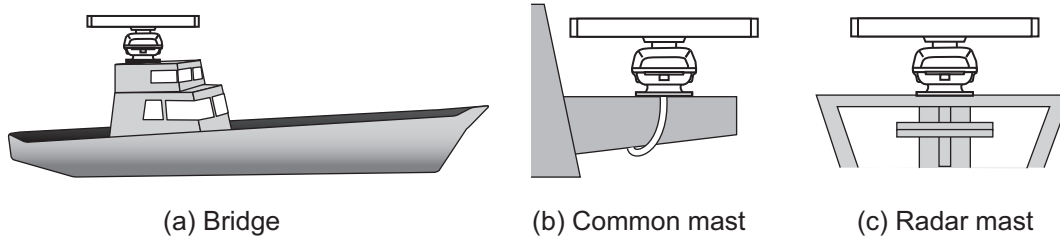

- A line of sight from the antenna unit to the bow of the ship must hit the surface of the sea in not more than 500 m or twice the ship's length, depending whichever value is smaller, for all load and trim conditions.

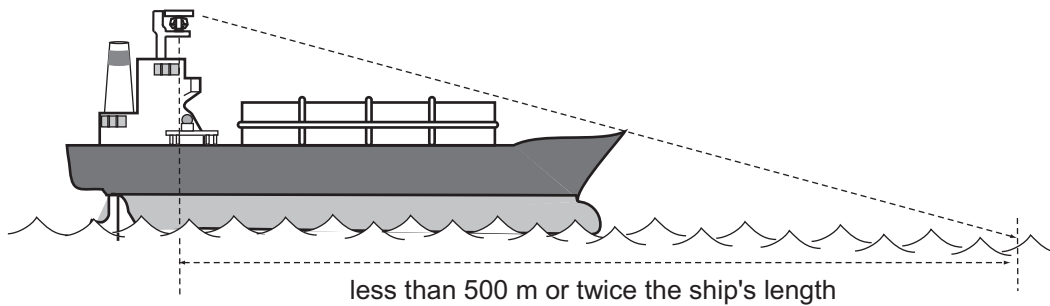

- Install the antenna unit so that any blind sectors caused by objects (mast, etc.) are kept to a minimum. A blind sector must not exist in arc of the horizon from right ahead to 22.5° aft of the beam to either side (see Figure 1 below). Also, individual blind sectors of more than 5° or the total arc of both blind sectors of more than 20°, must not occur in the remaining arc (see Figure 2 below). Note that any two blind sectors separated by 3° or less are regarded as one sector.

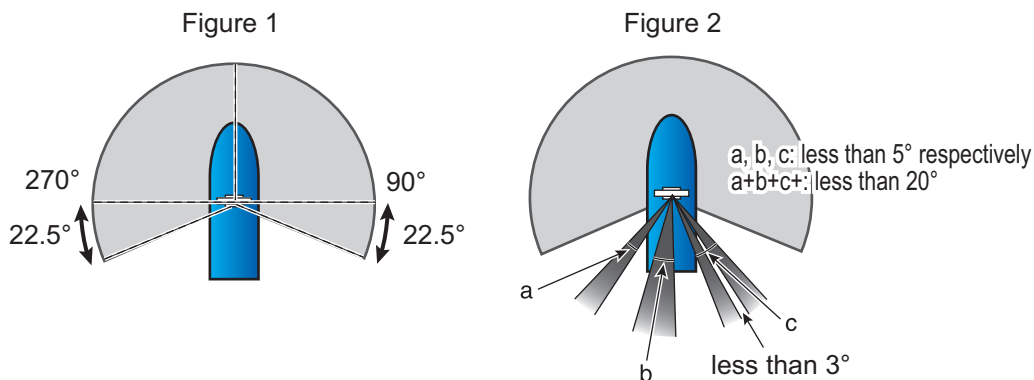

- Do not install the antenna where extreme winds may strike the port and starboard sides of the antenna.
- Install the antenna unit away from interfering high-power energy sources and TX radio antennas.

- Keep the following distance and angle between another radar antenna.

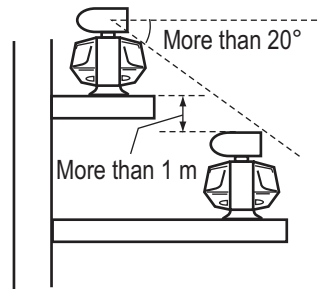

- Keep the lower edge of the antenna unit above the safety rail by at least 500 mm.
- No funnel, mast or derrick shall be within the vertical beamwidth of the antenna unit in the bow direction, especially zero degree  $\pm 5^\circ$ , to prevent blind sectors and false echoes on the radar picture.
- It is rarely possible to place the antenna unit where a completely clear view in all directions is available. Therefore, determine the angular width and relative bearing of any shadow sectors for their influence on the radar at the first opportunity after fitting.
- Locate the antenna of an EPFS clear of the radar antenna to prevent interference to the EPFS. A separation of more than two meters is recommended.
- A magnetic compass will be affected if the antenna unit is placed too close to the compass. Observe the compass safe distances on page ii to prevent interference to a magnetic compass.
- Do not paint the radiator aperture, to ensure proper emission of the radar waves.
- Ground the antenna unit with the supplied ground wire.
- Deposits and fumes from a funnel or other exhaust vent can affect the aerial performance and hot gases may distort the radiator portion. Do not install the antenna unit where the temperature is more than  $55^\circ\text{C}$  ( $131^\circ\text{F}$ ).
- Leave sufficient space around the unit for maintenance and servicing. See the antenna unit outline drawing for recommended maintenance space.

**Note:** For the IMO compliant radar, refer to IMO SN/Circ.271 "Guidelines for the installation of shipborne radar equipment" for further information.

## 1.3 How to Install the Antenna Unit for FAR-1513, FAR-1523

### 1.3.1 How to fasten the radiator to the radiator bracket

Make five holes in the platform - four holes to fasten the antenna unit and one hole for the signal cable, referring to the outline drawing at the back of this manual for the dimensions.

See the packing list at the back of this manual for the installation materials.

1. Remove the radiator cap from the radiator bracket.

## 1. INSTALLATION

2. Apply marine sealant to the surface of the antenna radiator and the radiator bracket. See the figure below for the location.

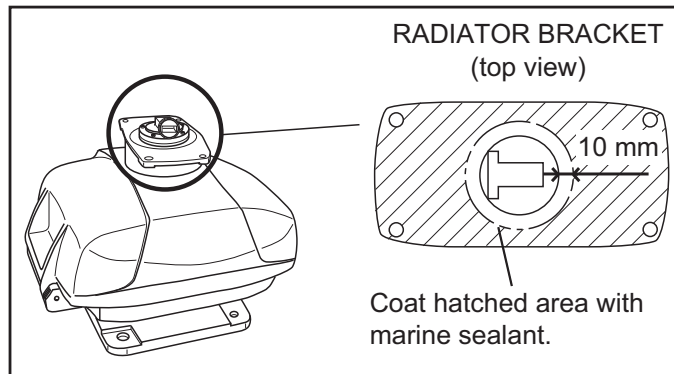

3. Apply the marine sealant to the threads in the four holes on the antenna radiator.
4. Apply the grease to the O-ring and set the O-ring in its groove on the radiator bracket.
5. Set the antenna radiator on the radiator bracket.
6. Fasten the antenna radiator to the radiator bracket with the hex bolts, flat washers and spring washers. Apply the marine sealant to the hex bolts.

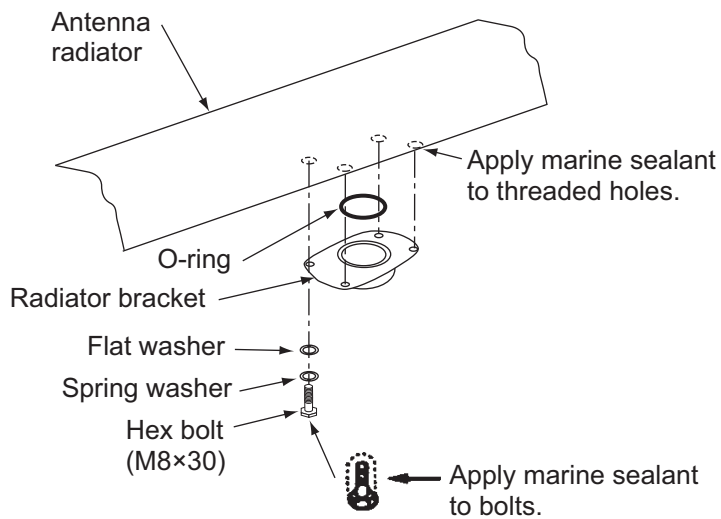

### 1.3.2 How to mount the antenna unit

The antenna unit may be assembled before hoisting it to the mounting platform. However, do not lift the antenna unit by the radiator. Always lift the unit by its housing. When using a crane or hoist, use the hoist rings which you attach to the antenna housing. See the figure below for hoisting guidelines.

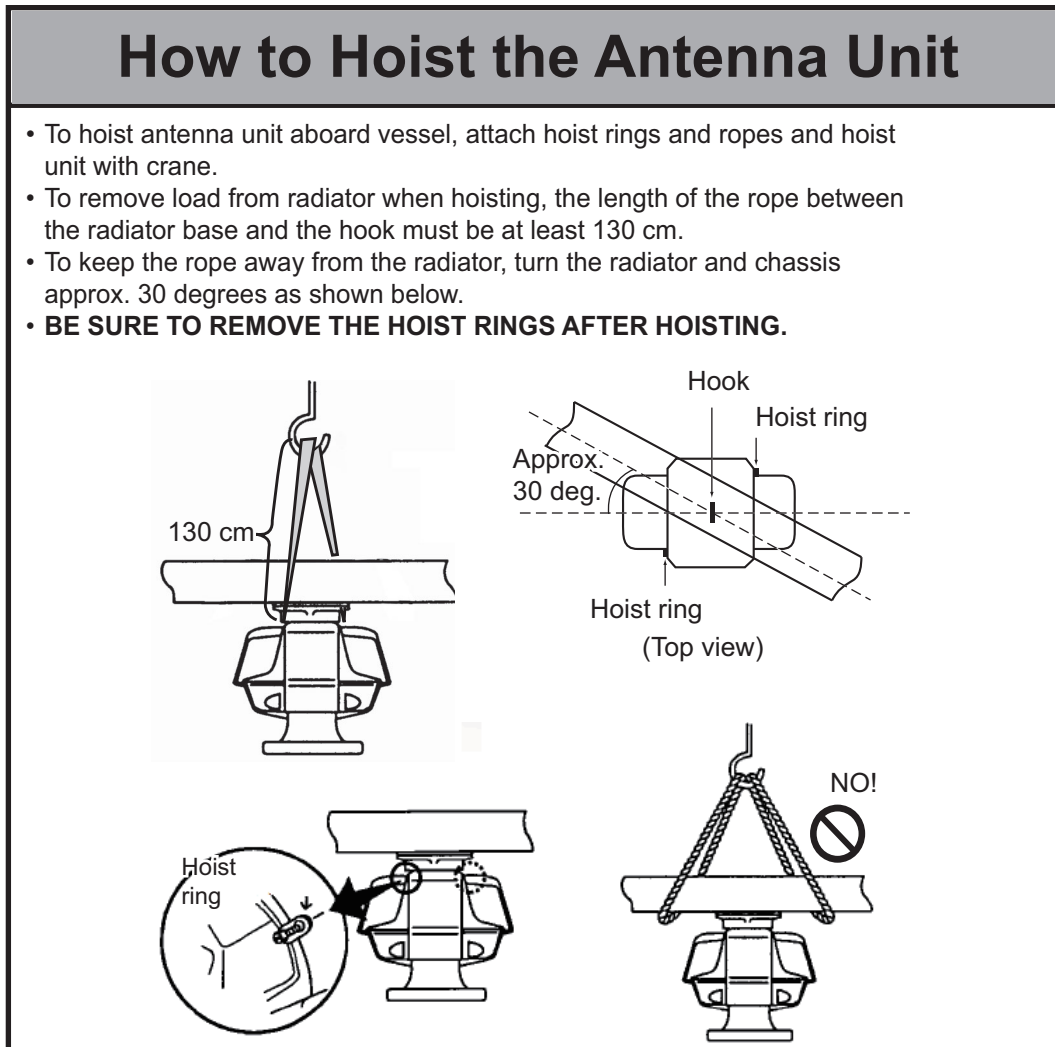

#### Mounting using the outside holes on the chassis

1. Put the anti-corrosion rubber (supplied) on the mounting location.
2. Referring to paragraph 1.4.2, hoist the antenna unit to the mounting location.
3. Orient the antenna unit so the bow mark on its base is aligned as close as possible with the ship's bow.

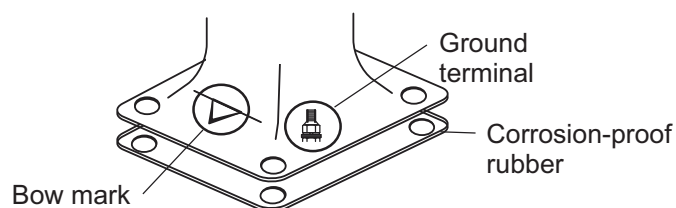

## 1. INSTALLATION

4. Set four hex bolts (M12×60, supplied) and seal washers (supplied) from the top of the antenna housing, as shown below.

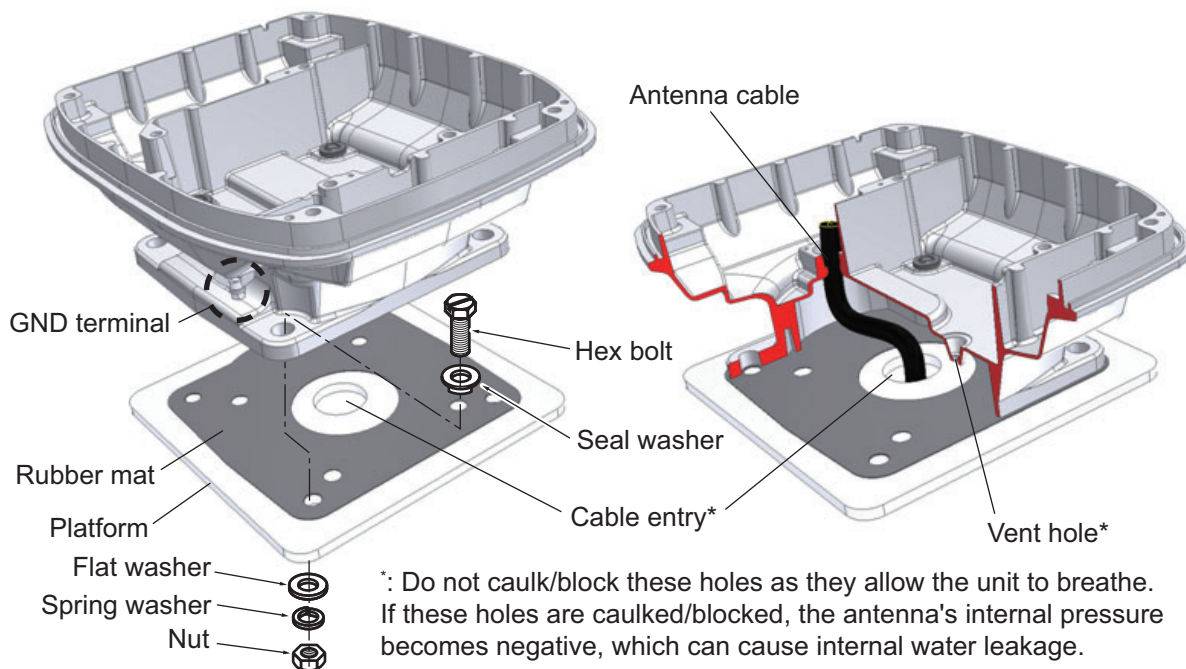

5. Set the flat washers (M12, supplied), spring washers (supplied) and nuts (supplied) to the hex bolts. Tighten by turning the nuts. Do not tighten by turning the hex bolts, to prevent damage to the seal washers.
6. Apply marine sealant to the flat washers, spring washers, nuts and visible parts of bolts.

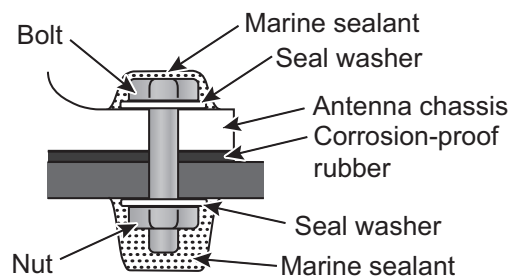

7. Prepare the ground point on the mounting platform. Use an M6×25 bolt, nut and flat washer (supplied). The ground point must be within 340 mm from the ground terminal on the antenna unit.
8. Fasten the ground wire (RW-4747, supplied) between the ground terminal and the ground point.
9. Apply marine sealant to the ground terminal and ground point as shown on the next page.

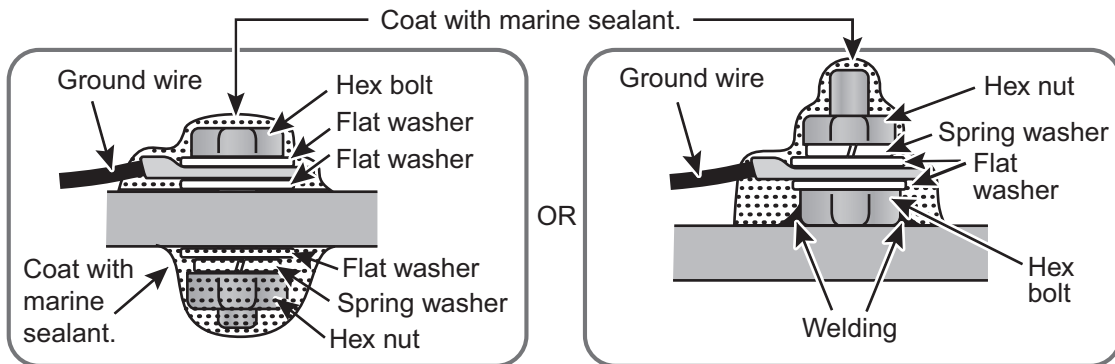

### **Mounting using the inside fixing holes**

This method requires removal of the RF unit in the antenna unit to access the inside fixing holes. Use hex bolts, flat washers, spring washers and nuts (local supply) to mount the antenna unit, confirming length of bolts.

1. Unfasten the four antenna bolts on the cover to open the antenna unit.
2. Unfasten the four screws on the RTB cover to remove it.
3. Unplug connector J827 and J834 on the RTB board.
4. Separate the upper chassis from the lower chassis by removing two hex bolts (M8×25).
5. Remove the RF unit by unfastening four hex bolts.

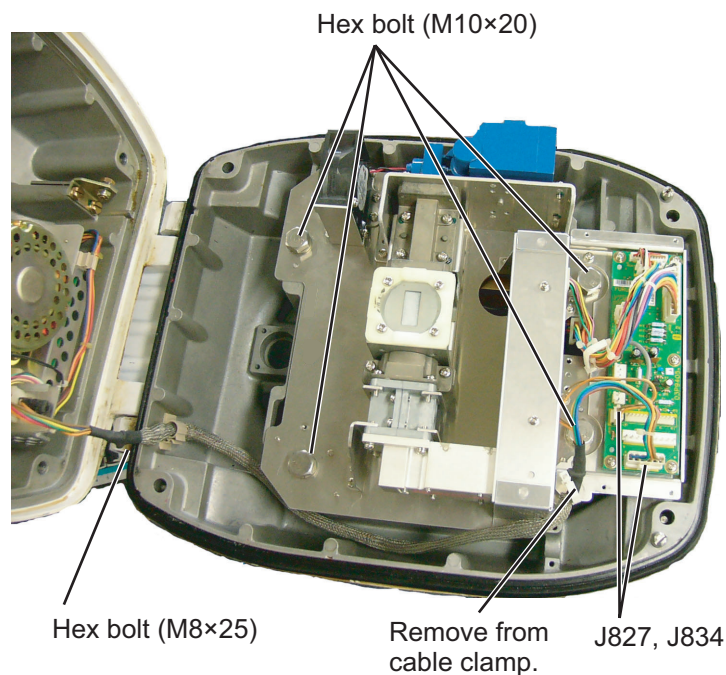

6. Lay the corrosion-proof rubber (supplied) on the mounting platform. Hoist the antenna unit to the mounting location, referring to paragraph 1.4.2.
7. Fasten the lower chassis to the mounting platform with hex head bolts, spring washers, flat washers and nuts (local supply). Coat flat washers, nuts and exposed parts of bolts with marine sealant. Cut a slit in the rubber bushing and insert bolt into the bushing. Do not use seal washers.
8. Reassemble the RF unit, cover and chassis.
9. Set four knob caps (supplied) into the outside fixing holes.

## 1.4 How to Install the Antenna Unit for FAR-1518, FAR-1528

### 1.4.1 How to fasten the radiator to the radiator bracket

The antenna unit consists of the antenna radiator and the antenna unit chassis, and they are packed separately. Fasten the antenna radiator to the antenna unit chassis as shown below.

1. For the **XN20AF, XN24AF**, Attach two guide pins to the underside of the antenna radiator.
2. Remove the waveguide cap from the radiator bracket. The cap may be discarded.
3. Coat the waveguide flange with marine sealant as shown below.

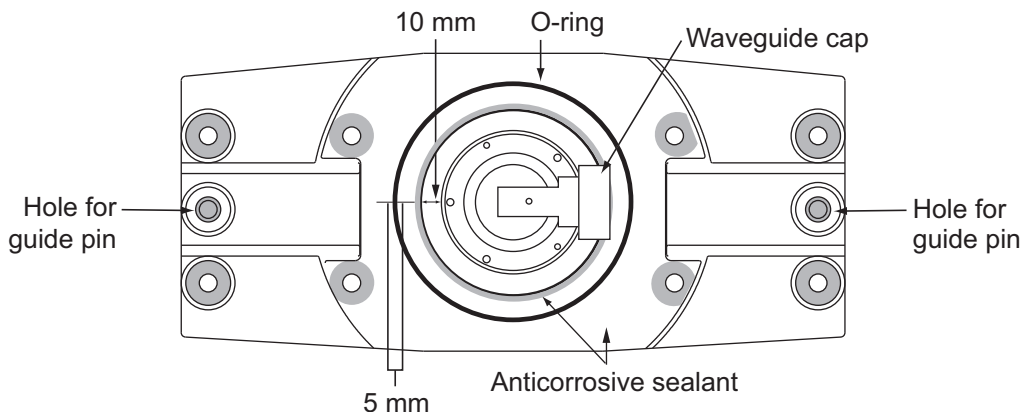

4. Coat the fixing holes for the antenna radiator with marine sealant.
5. Grease the O-ring and set it to the O-ring groove on the radiator flange.
6. Set the antenna radiator to the radiator bracket.
7. Coat the hex bolts with marine sealant and use them to loosely fasten the antenna radiator to the antenna unit chassis.
8. For the **XN20AF, XN24AF**, remove two guide pins (inserted at step 1).
9. Tighten the hex bolts.

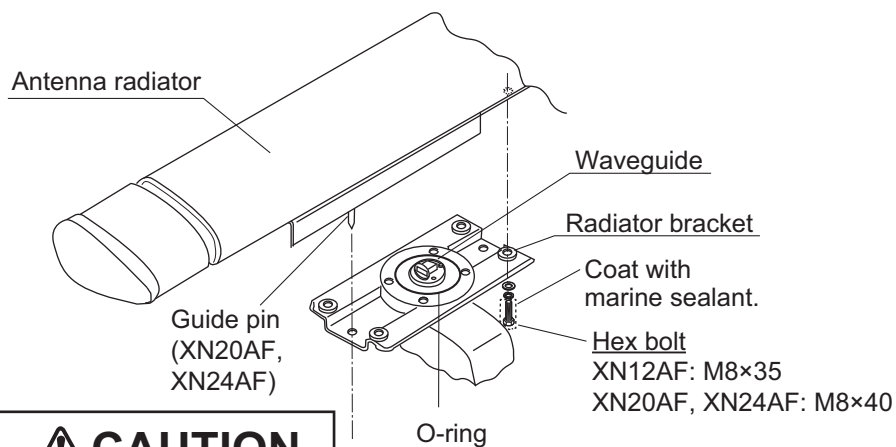

### **CAUTION**

**Be sure to remove the guide pins.**  
Injury may result if the guide pins loosen and fall.

## 1.4.2 How to mount the antenna unit

The antenna unit may be assembled before hoisting it to the mounting platform. However, do not lift the antenna unit by the radiator. Always lift the unit by its housing. When using a crane or hoist, use the hoist rings which you attach to the antenna housing. See the hoisting guidelines on page 1-5.

1. Construct a suitable mounting platform referring to the outline drawing at the end of this manual.
2. Drill four mounting holes of 15 mm diameter and one cable entry hole of approx. 50 mm diameter in the mounting platform.
3. Lay the corrosion-proof rubber (supplied) on the mounting platform.
4. Place the antenna unit on the corrosion-proof rubber, and orient the unit so the bow mark on its base faces the ship's bow.

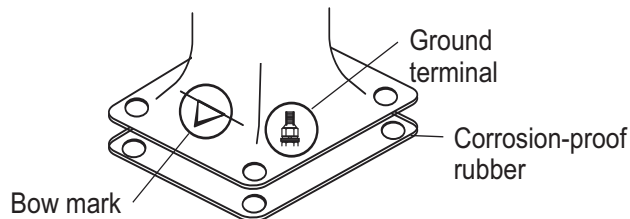

5. Fasten the antenna unit with hex bolts (M12×60), flat washers, spring washers, and seal washers. See the illustration on page 1-6 for details.
6. As shown in the figure below, use hex bolt (M6×25), hex nut (M6), flat washers (M6) and spring washers (M6) to establish the ground system on the mounting platform. The location of the grounding point should be within 340 mm of the ground terminal on the antenna unit, since that is the length of the ground wire. Connect the ground wire (RW-4747, supplied) between the grounding point and the ground terminal on the antenna unit. Coat the entire ground system with marine sealant (supplied).

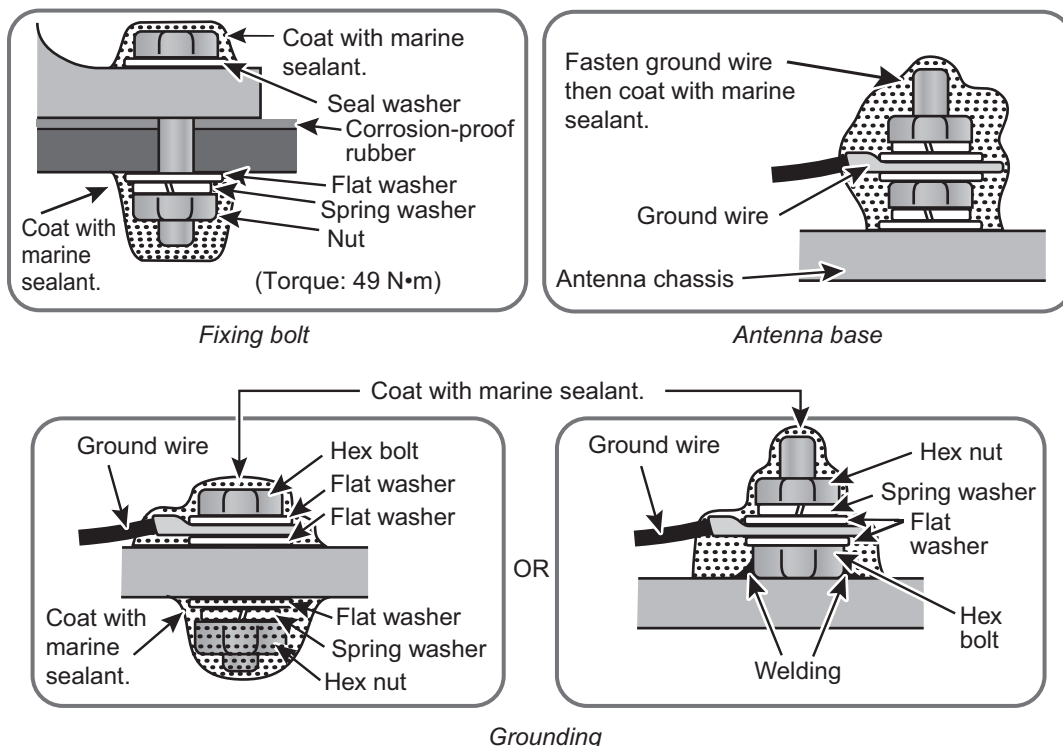

7. Detach the hoist rings (if they have not already been detached).

## 1.5 Processor Unit

### 1.5.1 Mounting considerations

The processor unit can be mounted on a desktop or bulkhead. When selecting a mounting location, keep in mind the following points.

- Locate the unit out of direct sunlight and away from heat sources because of heat that can build up inside the cabinet.
- Locate the equipment away from places subject to water splash and rain.
- Select a mounting location considering the length of the cables connected.
- For bulkhead mounting, make sure the mounting location is strong enough to support the weight of the unit under the vibration normally encountered on the vessel. Reinforce the mounting location if necessary.
- Leave sufficient space on the sides and rear of the unit to facilitate maintenance. (See the outline drawing at the back of this manual for recommended maintenance space.)
- A magnetic compass will be affected if placed too close to the processor unit. Observe the compass safe distances shown on page ii to prevent interference to a magnetic compass.

### 1.5.2 How to mount the processor unit

#### Desktop installation

Fasten the unit with four bolts (M5, supplied) or self-tapping screws (5×20, local supply).

**Note:** If the installation must meet the waterproofing standard IPX2, install the processor unit IPX2 kit. See paragraph 2.4.5 for details.

#### Bulkhead installation

Mark locations for four self-tapping screws if screws will be used. Insert four M5 bolts (or self-tapping screws), leaving approx. 5 mm of the bolts (screws) exposed. Hang the processor unit on the four bolts (screws). Tighten all bolts (screws).

**Note:** If the installation must meet the waterproofing standard IPX2, set the blind seal supplied with the processor unit installation materials (CP03-36501) to the hole on the unit as shown in the right figure.

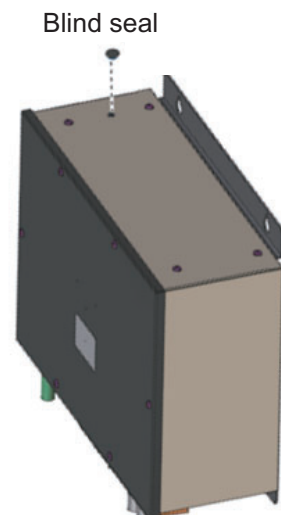

## 1.6 Display Unit

See the operator's manual for MU-150HD (OMC-44560) and MU-190 (OMC-33670) for the installation procedure. Keep in mind the following points when selecting a location.

- Locate the display unit where no framing is installed immediately forward of the display unit.
- Locate the display unit where it is easy to view the display in all ambient lighting conditions.

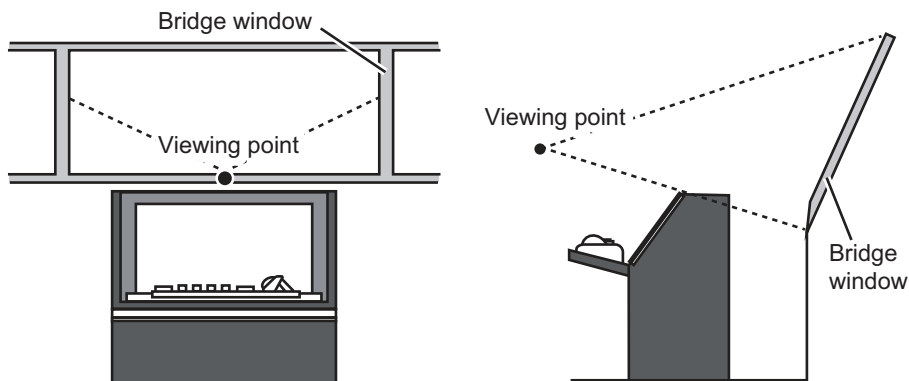

## 1.7 Control Unit

The control unit (RCU-028) is designed to be fixed to a desktop. Install the control unit within five meters from the processor unit since the length of the cable connecting them is five meters.

Provide fixing screws locally (self-tapping screw, 4 pcs.,  $\phi 4$ ). Be sure their lengths are long enough.

**Note:** The cable for the RCU-028 is attached to the control unit, and is covered with a plastic bag at the factory for waterproofing. If the connector will not be used, do not remove the plastic bag. If the connector is to be used, use heat shrink tubing and vinyl to waterproof the connector. See section 2.5 for details.

1. Drill four mounting holes of 5 mm diameter referring to the outline drawing at the back of this manual.
2. Fix the control unit with four self-tapping screws from the top of the control unit.
3. Attach four cosmetic caps to the fixing holes on the control unit.

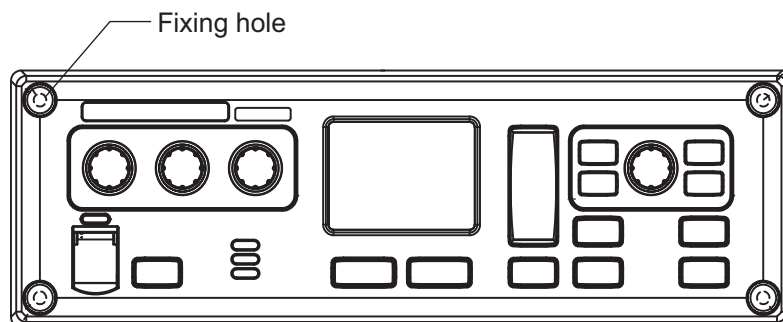

## 1.8 Trackball Control Unit (option)

### How to mount the unit tilted

Use the desk fixing plate to mount the unit tilted on a desktop. Fasten the desk fixing plate to the bottom of the control unit. Fasten the control unit to the desktop with self-tapping screws (local supply).

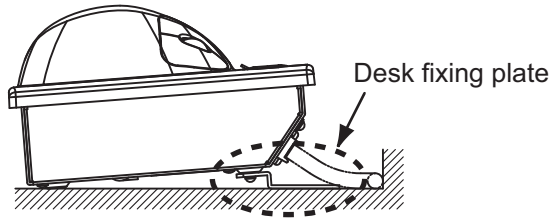

### How to mount the unit flush with mounting surface

Drill four mounting holes of 5 mm in diameter in the mounting location, referring to the outline drawing at the back of this manual. Fasten the control unit with four M4 screws (local supply) from the underside of the desk.

# 2. WIRING

## 2.1 Wiring Outline

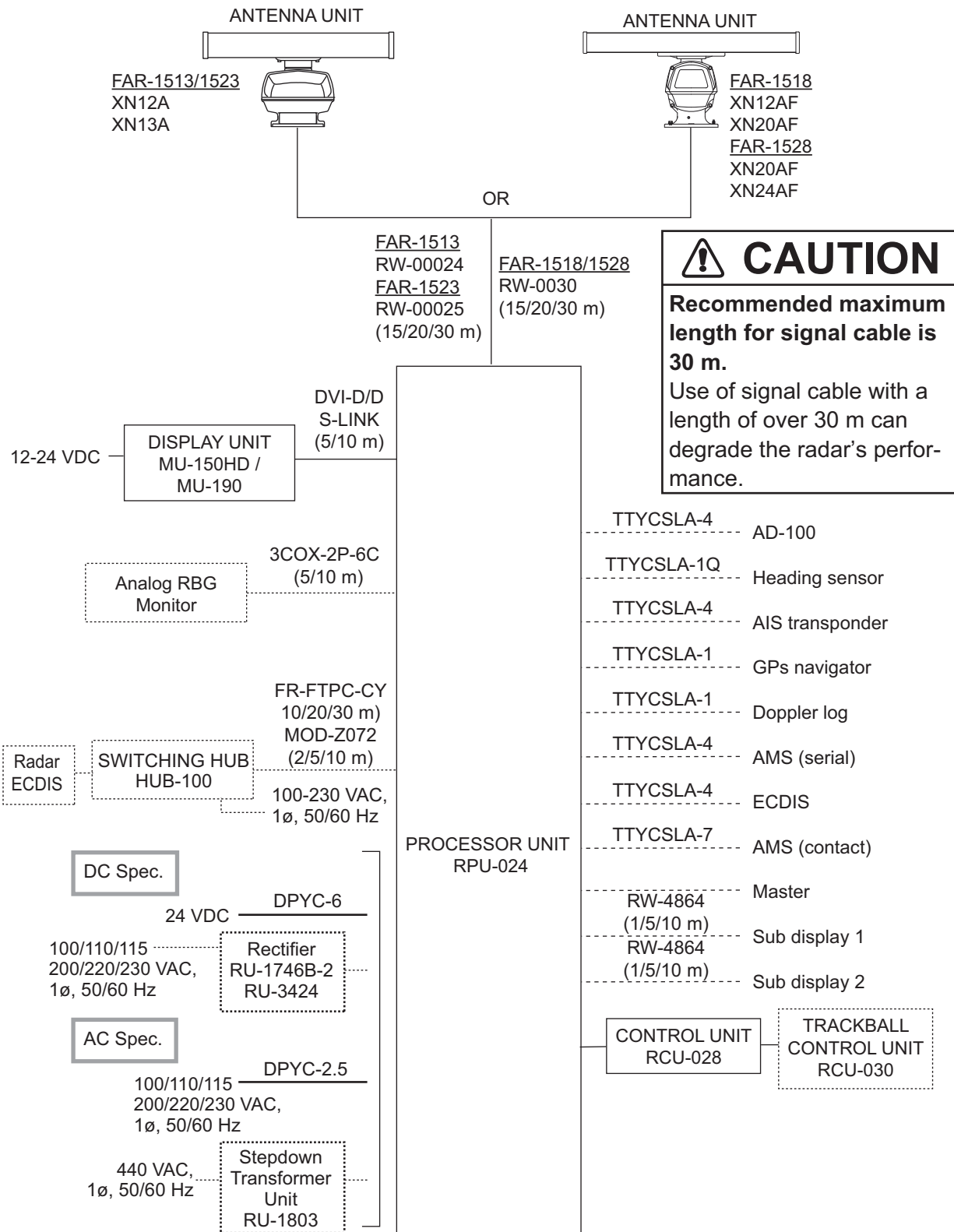

## 2.2 How to Connect the Signal Cable for FAR-1513, FAR-1523

In order to minimize the chance of picking up electrical interference, avoid where possible routing the signal cable near other onboard electrical equipment. Also, avoid running the cable in parallel with power cables.

This signal is ready for connection; no fabrication is required. Connect the cable as shown below.

1. Open the antenna cover by loosening four bolts, and then fix the stay.

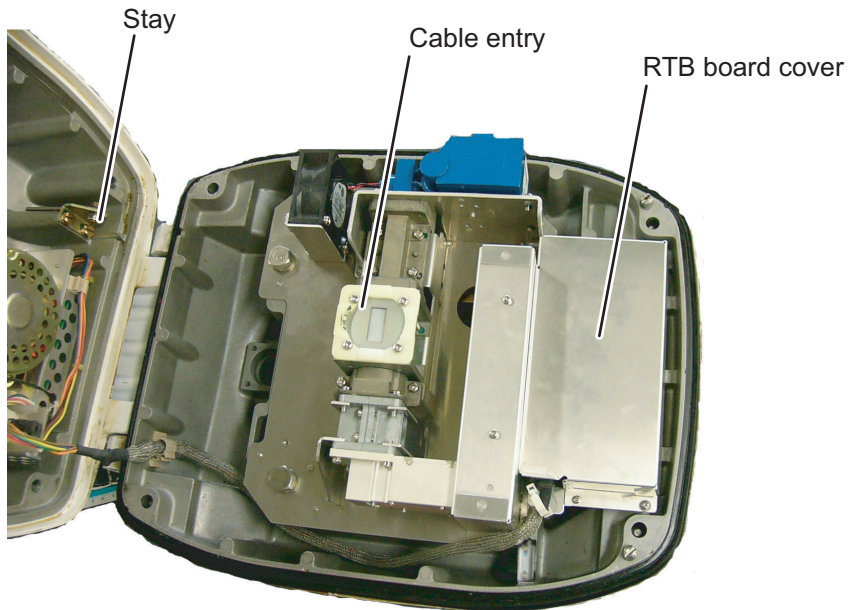

2. Unfasten the cable gland assembly (gasket, flat washer).
3. Pass the signal cable with connector through the bottom of the antenna unit chassis. Pass the cable through the gland assembly as shown below.

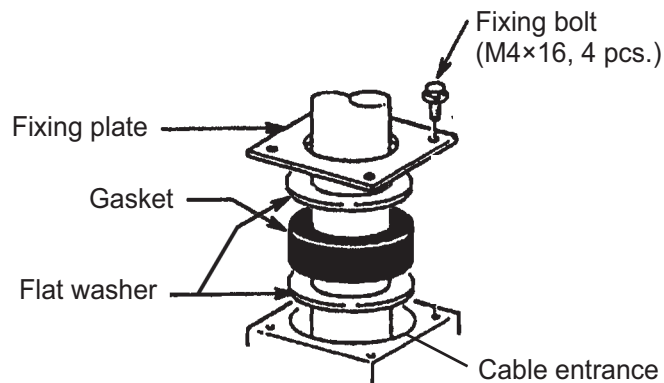

4. Fasten the fixing plate with four bolts.

- Referring to the figure below, fasten the crimp-on lug on the shield to one of the fixing bolts of the cable gland assembly.

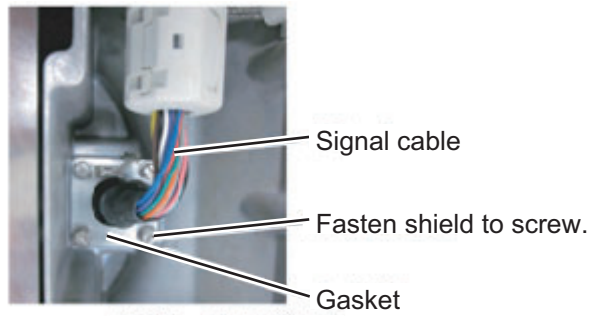

- Unfasten the four screws fixing the RTB cover. Slide the cover to access the RTB board.
- Connect the plugs of the signal cable to the RTB board.

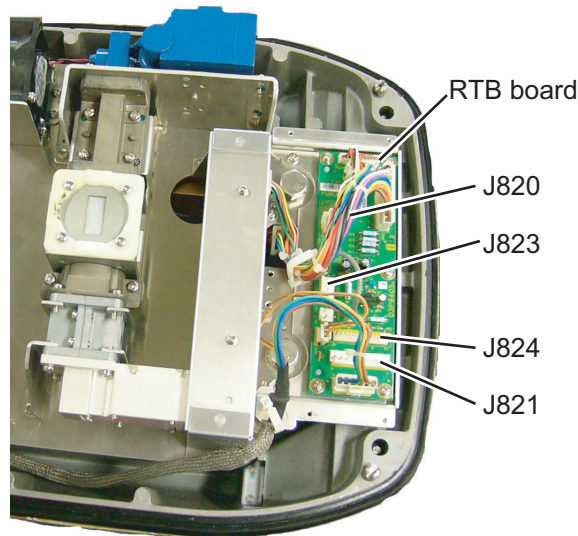

- Close the RTB board cover.
- Attach three EMI cores to the signal cable at the locations shown below.

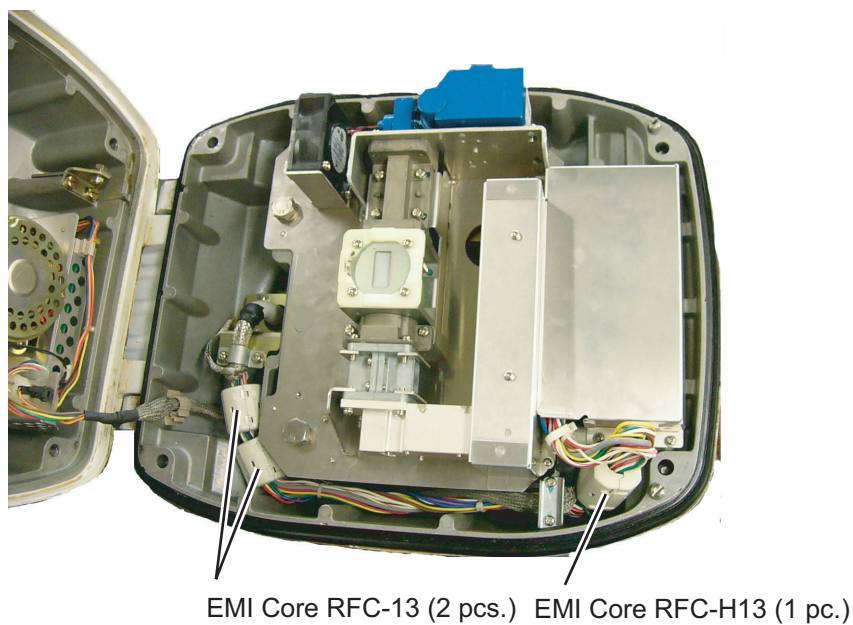

## 2. WIRING

10. Fasten the signal cable with the cable clamp as follows.

a) Dismount the cable clamping plate and remove the clamp and cushion.

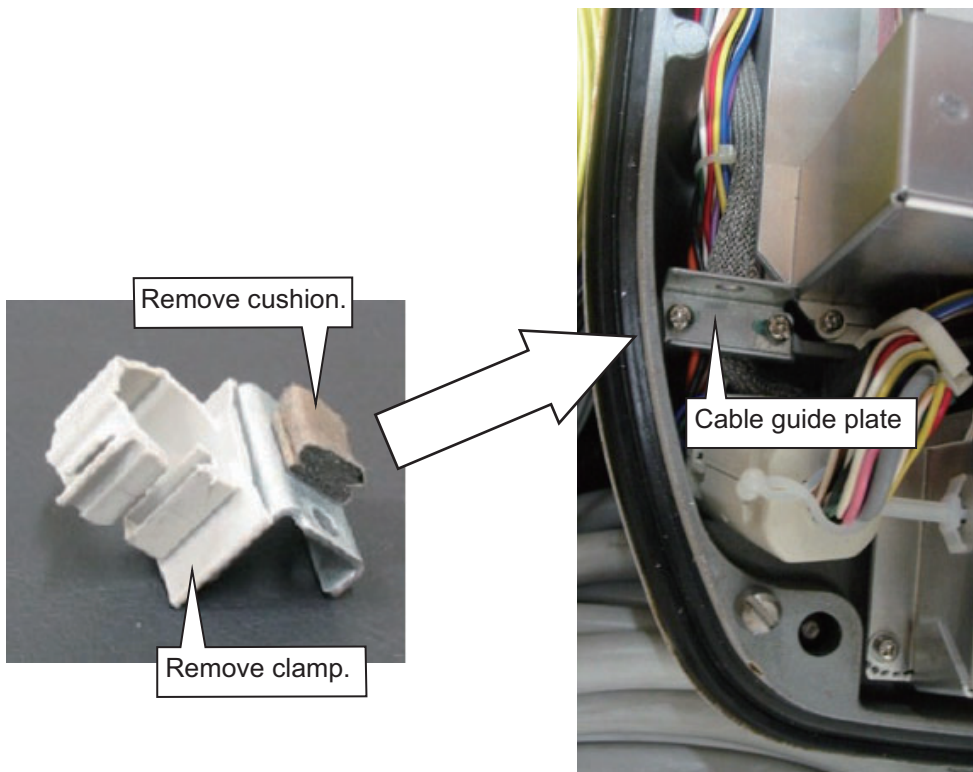

b) Pass the signal cable through the cable channel, then refasten the cable guide plate

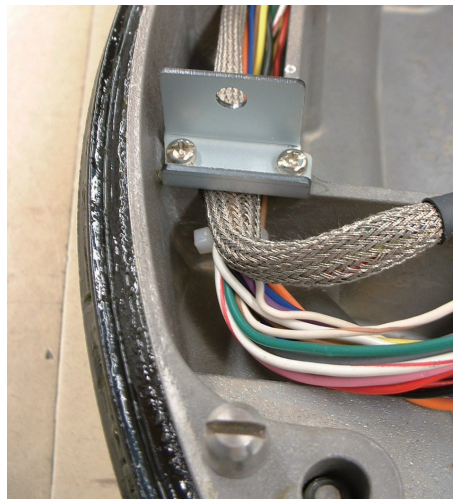

c) Fasten the signal cable with the cable clamp as shown below.

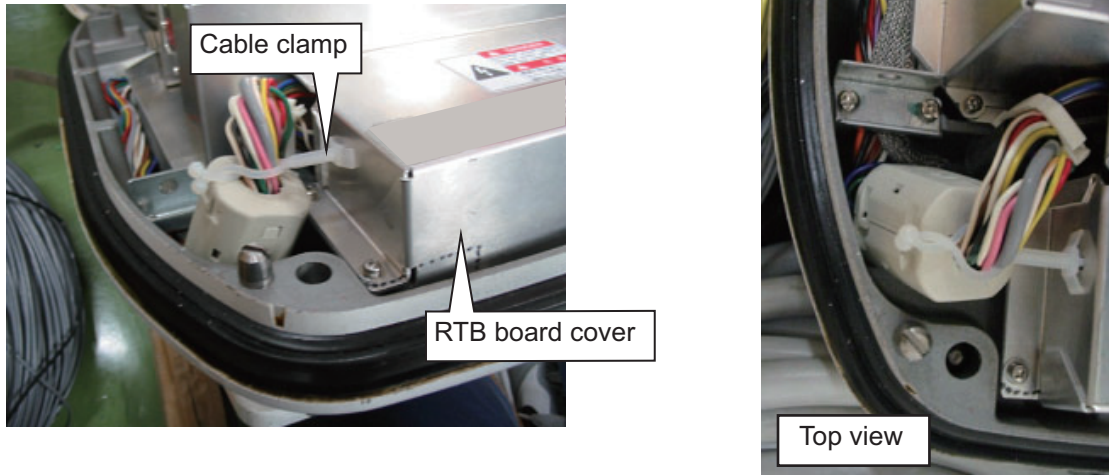

11. Release the stay and close the cover. Loosely fasten the fixing bolts; you will have to make some adjustments inside after completion of wiring.

**Note:** When closing the cover, set the gaskets to the grooves in the bottom chassis, then tighten the fixing bolts.

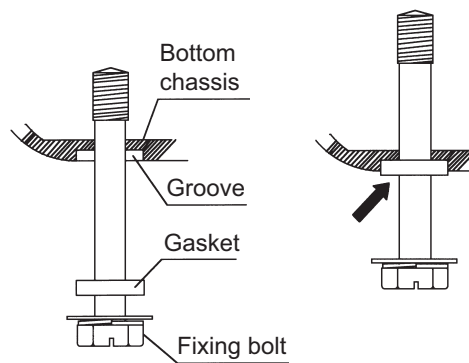

Torque :  $9.8 \pm 0.1$  Nm

## 2.3 How to Connect the Signal Cable for FAR-1518, FAR-1528

In order to minimize the chance of picking up electrical interference, avoid where possible routing the signal cable near other onboard electrical equipment. Also, avoid running the cable in parallel with power cables.

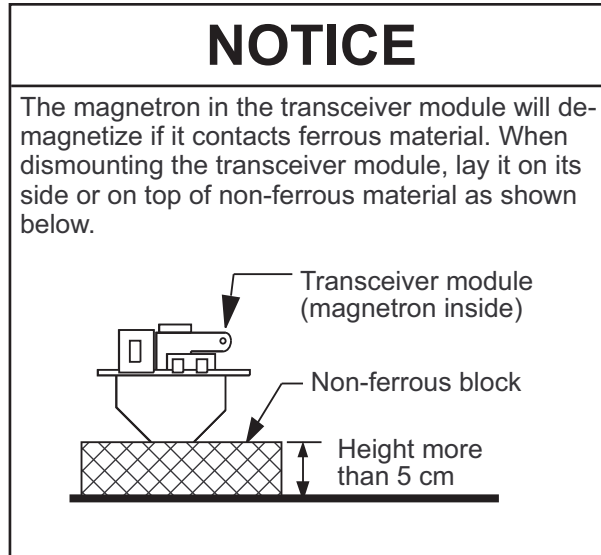

1. Open the antenna cover.
2. Disconnect the plugs P821, P822, P801 and P802.

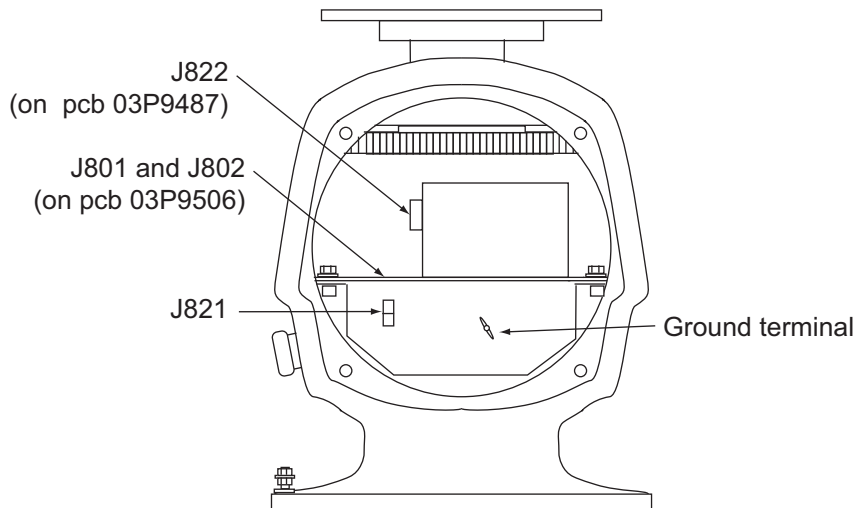

3. Unfasten two bolts to dismount the transceiver module. Remove the transceiver module.
4. Unfasten the four fixing bolts on the cable gland at the base of the antenna unit. Remove clamping ring, rubber gasket and flat washers. Save them for later use.
5. Pass the signal cable through the cable entry hole in the antenna unit mounting platform. Trim the cable to 500 mm length from the cable gland.

6. Slide flat washers, rubber gasket and clamping ring onto the cable in the order shown below.

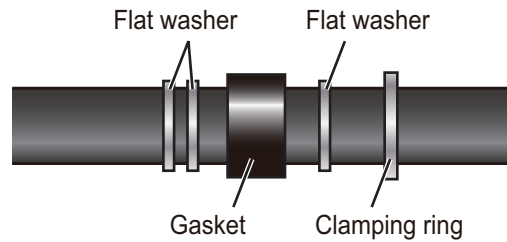

7. Fabricate the signal cable as shown below.
- 1) Remove the vinyl sheath 500 mm.
  - 2) Trim the armor and vinyl sheath (inner) so their lengths are 10 mm and 20 mm, respectively. Unravel the shield to expose the cable cores.
  - 3) Make the length of the cable cores 430 mm.
  - 4) Make the lengths of the inner and outer shields 510 mm. Twist the inner and outer shields together and attach crimp-on lug FV5.5-4 (yellow,  $\phi 4$ ).
  - 5) Remove insulation of each core except the coaxial cable approx. 8 mm.
  - 6) Make the length of the core of the coaxial cable approx. 10 mm. Fold back shield onto the coaxial cable.

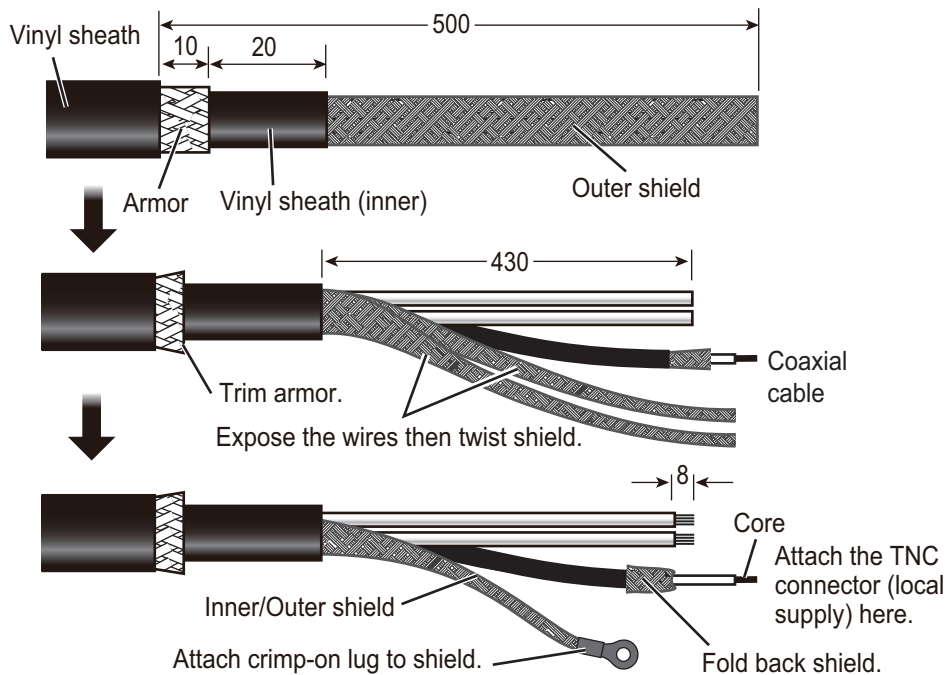

## 2. WIRING

- Pass the shield between the clamping ring and the washer as shown below. Fasten the clamping ring with the screws.

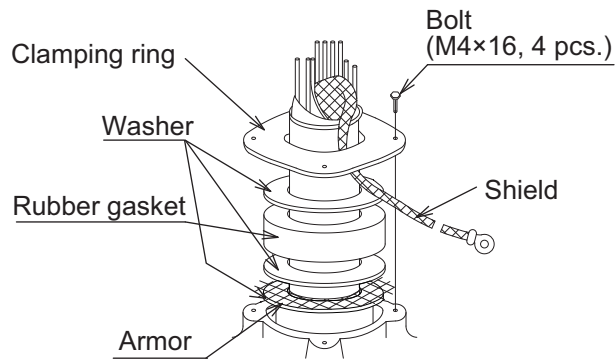

- Connect the signal cable to TB801, TB802 and TB803 on the RF board (03P9488), referring to the interconnection diagram.

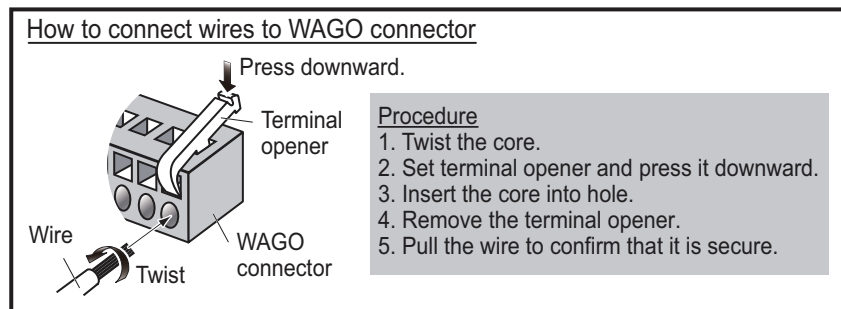
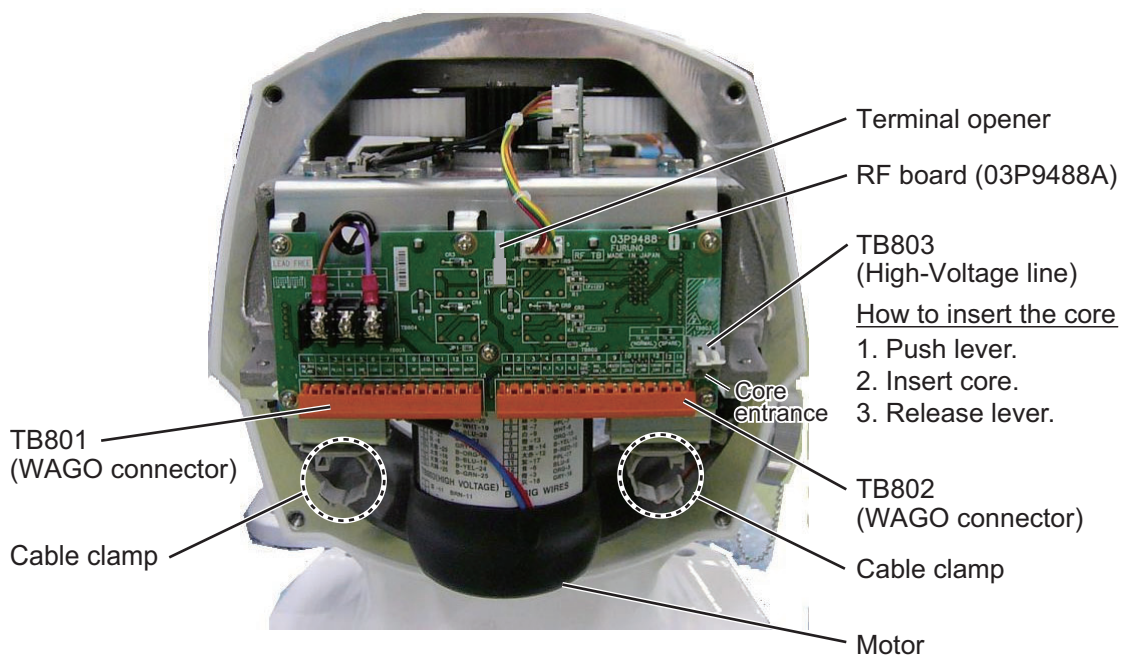

10. Pass the coaxial cable under the transceiver fixing plate (arrow) and the clamp (dashed circle).

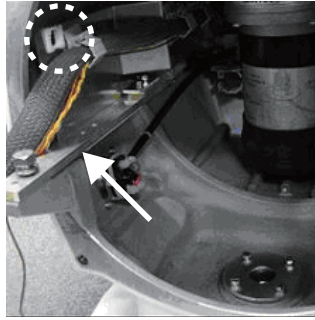

11. Detach the junction box from the transceiver unit.

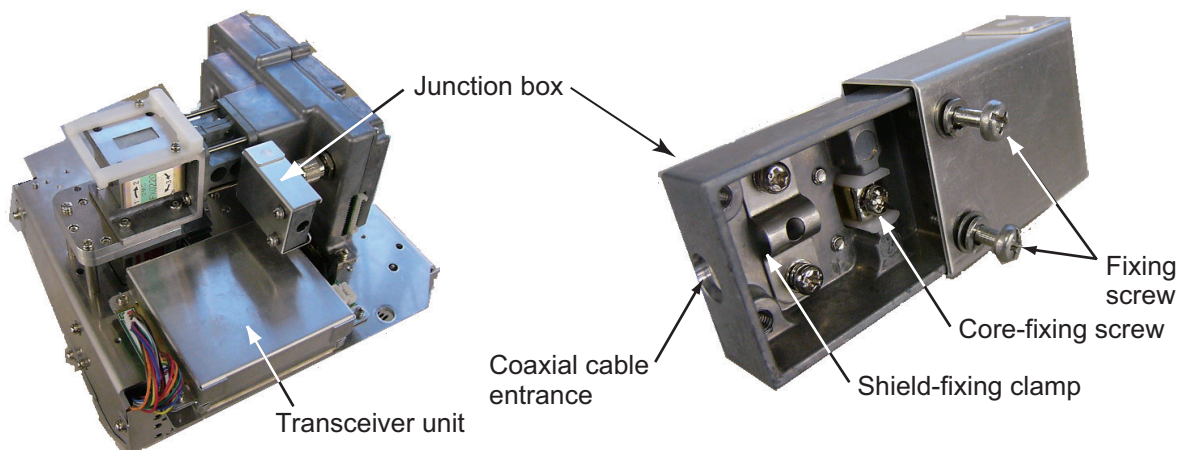

12. Loosen the two screws on the junction box, then slide the cover to open the box. Connect the coaxial cable as shown below.

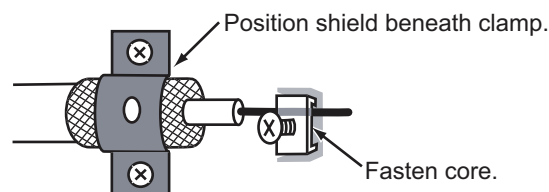

13. Close the junction box and tighten the screws. Reattach the box to the transceiver unit.
14. Reconnect the plugs disconnected at step 2.
15. Set the transceiver module to the antenna unit and push the module in until it stops. Tighten the fixing bolts. **Be sure to push in the transceiver unit until it stops. Failure to do so may cause microwave leakage.**
16. Fasten the shield wire to the wing nut on the transceiver module.
17. Confirm that all screws are tightened and all wiring is properly made. Confirm that the waterproofing gasket, bolts and tapping holes of the antenna unit are coated with silicone grease.
18. Close the antenna unit cover.

## 2.4 Processor Unit

The illustration below is the AC specification unit. The DC specification unit does not have the fuse.

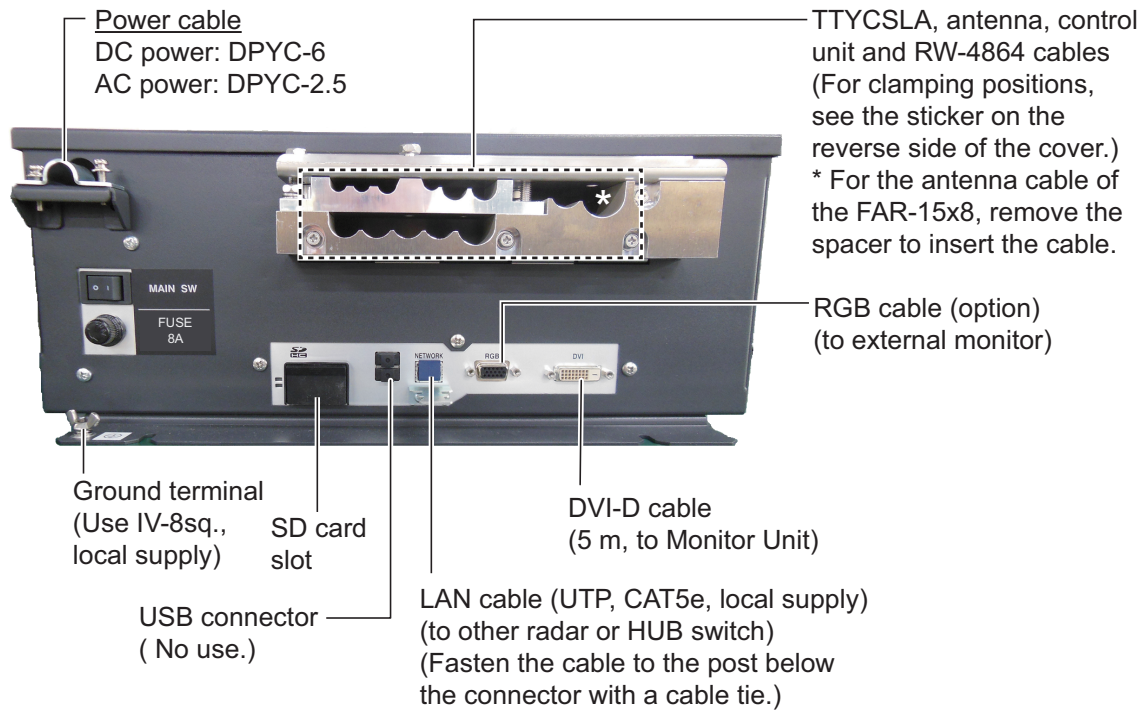

### 2.4.1 How to fabricate the power cable

1. Remove the armor of the cable by the amount shown in the figure below.
2. Remove the insulation of the cores 10 mm.
3. Fix crimp-on lugs (FV5.5-4, yellow, supplied) to the cores. Cover the end of the armor with vinyl tape. Lay the cable in the cable clamp on the cable entry side of the processor unit. Fasten the cable clamp.
4. Fasten the crimp-on lugs to the terminal block inside the unit, referring to the interconnection diagram at the back of this manual.

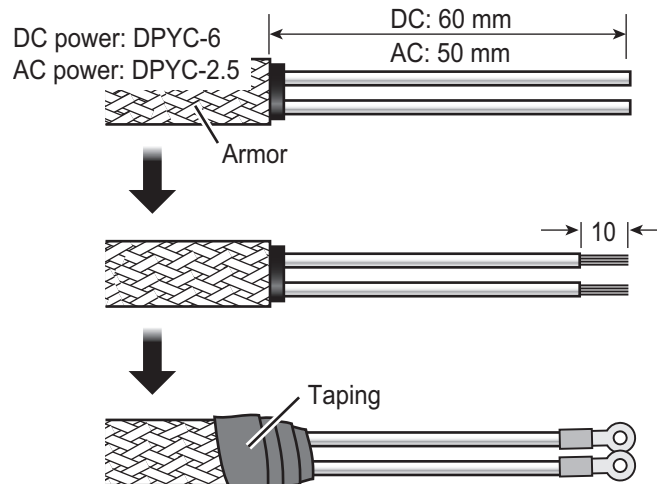

## 2.4.2 How to fabricate signal cable, cables from external equipment

### Signal cable for FAR-1518, FAR-1528

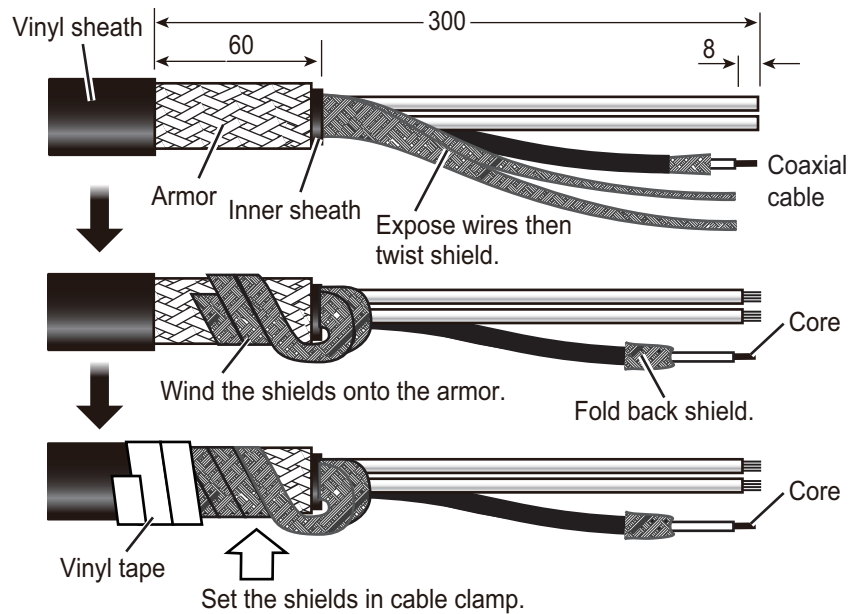

### Signal cable for FAR-1513, FAR-1523

This cable is ready for connection; no fabrication is required.

**TTYCS, TTYCSLA cables (for external equipment)**

For lengths, see the table on the next page

*How to fabricate the TTYCS series cable*

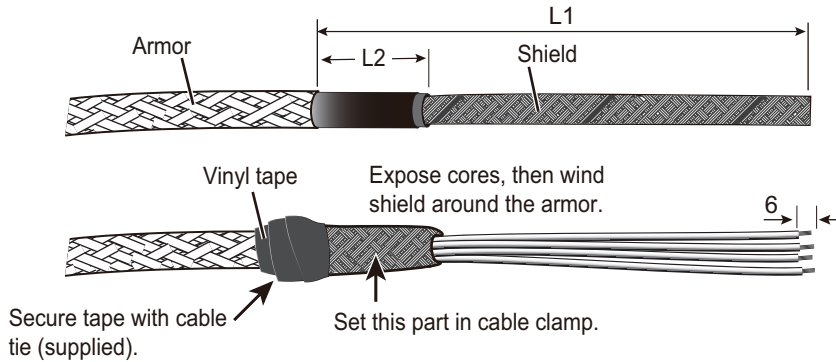

*How to fabricate the TTYCSLA series cable*

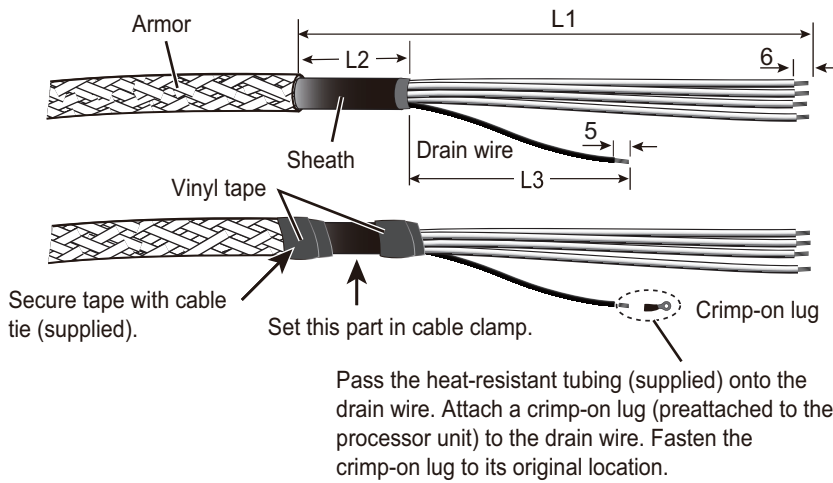

**How to connect wires to WAGO connector**

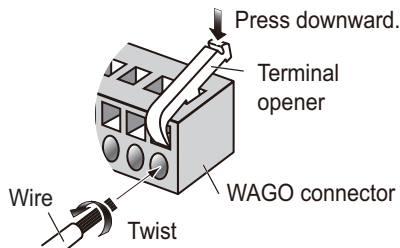

- <Procedure>
1. Twist the cores.
  2. Press the terminal opener downward.
  3. Insert the wire into the hole.
  4. Remove the terminal opener.
  5. Pull the wire to confirm that it is secure.

**Connector, cable and lengths (L1, L2 and L3)**

Connector No.	Cable type	L1	L2	L3
J613 (Ext. alarm contact signal)	TTYCSLA-7	300	70	150
J614 (HDG)	TTYCSLA-1Q	250	70	150
J615 (AIS)	TTYCSLA-4	200	70	200
J616 (GPS), J617 (LOG)	TTYCSLA-1	200	70	200
J618/J619/J620 (AMS/ECDIS/AD-10)	TTYCSLA-4	200	70	200

**LAN cable**

If the LAN cable is not fitted with an RJ-45 connector, attach one as shown below. Connect the cable to J202 (on the outside of the processor unit.)



Expose inner vinyl sheath.

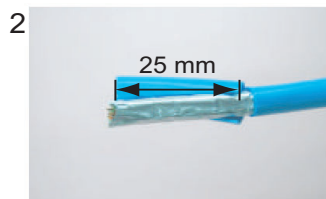

Remove the outer sheath by approx 25 mm. Be careful not to damage inner shield and cores.

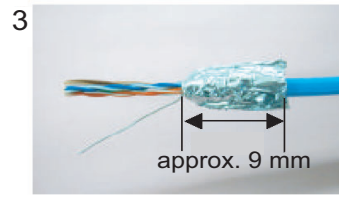

Fold back the shield, wrap it onto the outer sheath and cut it, leaving 9 mm.

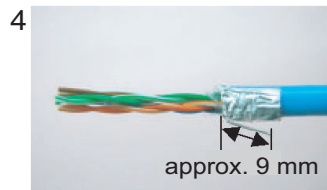

Fold back drain wire and cut it, leaving 9 mm.

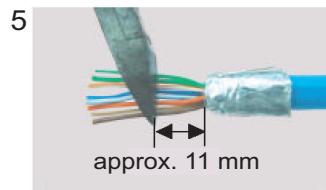

Straighten and flatten the core in order and cut them, leaving 11 mm.



Insert the cable into the modular plug so that the folded part of the shield enters into the plug housing. The drain wire should be located on the tab side of the jack.



Using special crimping tool MPT5-8AS (PANDUIT CORP.), crimp the modular plug. Finally check the plug visually.

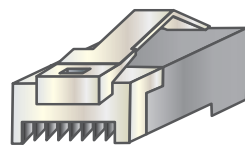

↑ ↑ Modular plug  
1 8 [Crossover cable]

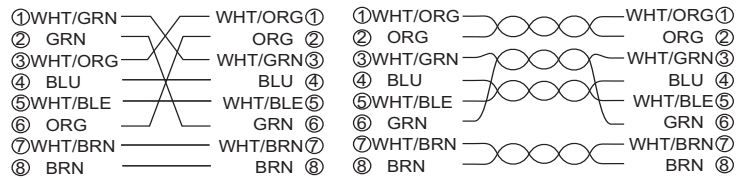

**2.4.3 Cable for sub display unit (RW-4864)**

Two sub display units can be connected to this radar when it functions as the main radar. Use the optional cable RW-4864 to connect the sub display unit to the main radar. Connect the no. 1 sub display unit to J612; the no. 2 sub display unit to J611.

## 2. WIRING

### 2.4.4 Where to connect cables inside the processor unit

Connect the antenna cable and the cables of external equipment to the FRP\_TB board (03P9601) inside the processor unit as shown below.

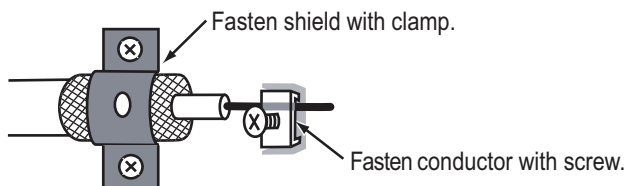
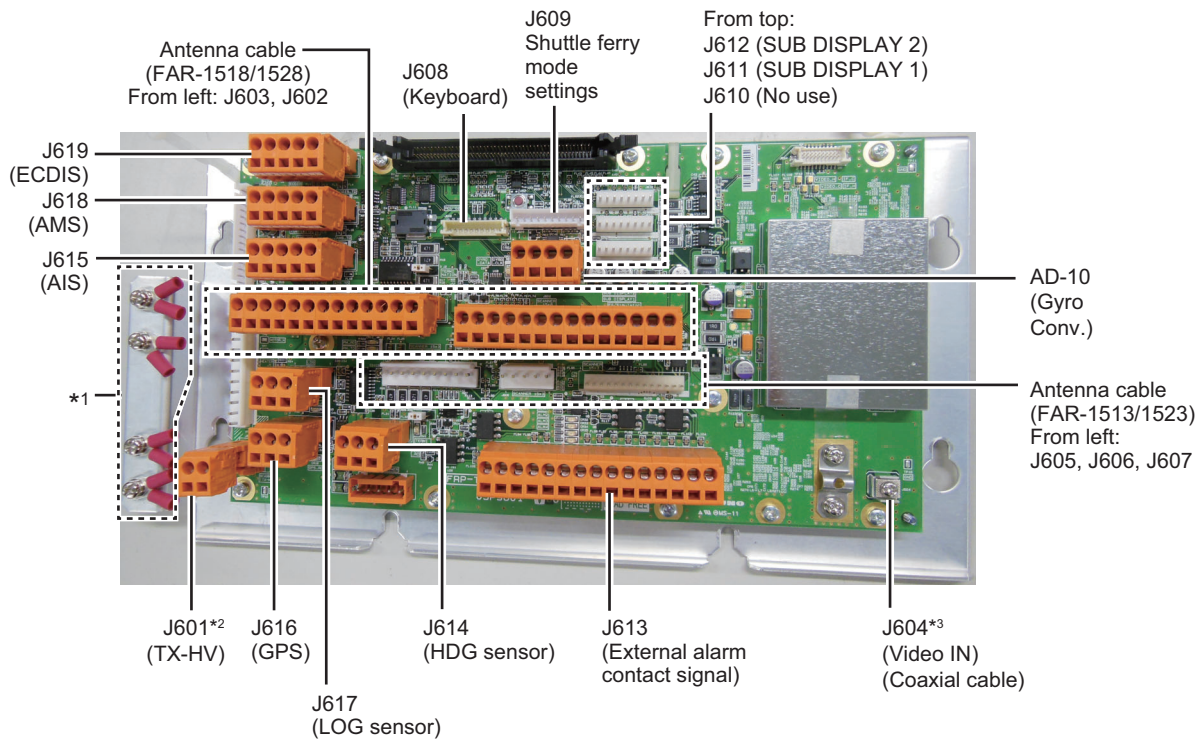

## 2.4.5 How to install the optional processor unit IPX2 kit

The optional processor unit IPX2 kit (OP03-238) has two rainproofing covers that protect the cables and connectors of the processor unit to waterproofing standard IPX2.

Name	Type	Code no.	Qty
Rainproof Cover 2	03-186-1104	100-401-840-10	1
Rainproof Cover	03-186-1105	100-401-850-10	1

**Note:** The installation also uses the blind seal that is supplied with the processor unit installation materials.

### How to attach the Rainproof Cover 2

1. Unfasten the two screws circled in the figure below.

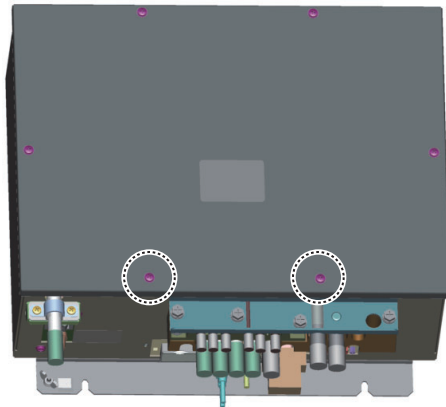

2. Fasten the Rainproof Cover 2 (03-186-1104) with the two screws unfastened at step 1.

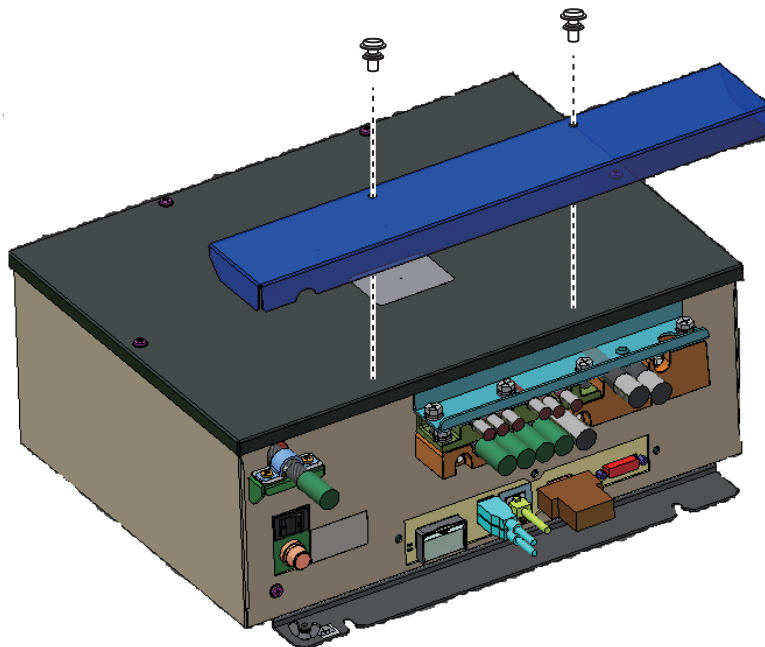

## 2. WIRING

### How to attach the Rainproof Cover

1. Unfasten the three screws circled in the figure below.

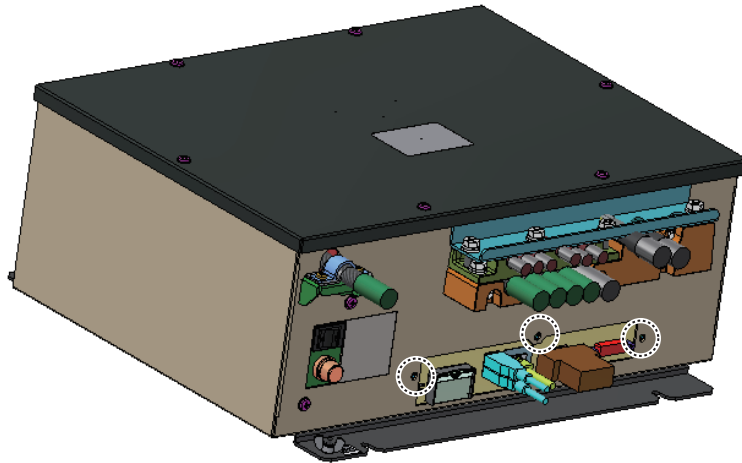

2. Fasten the Rainproof Cover (03-186-1105) with the three screws unfastened at step 1.

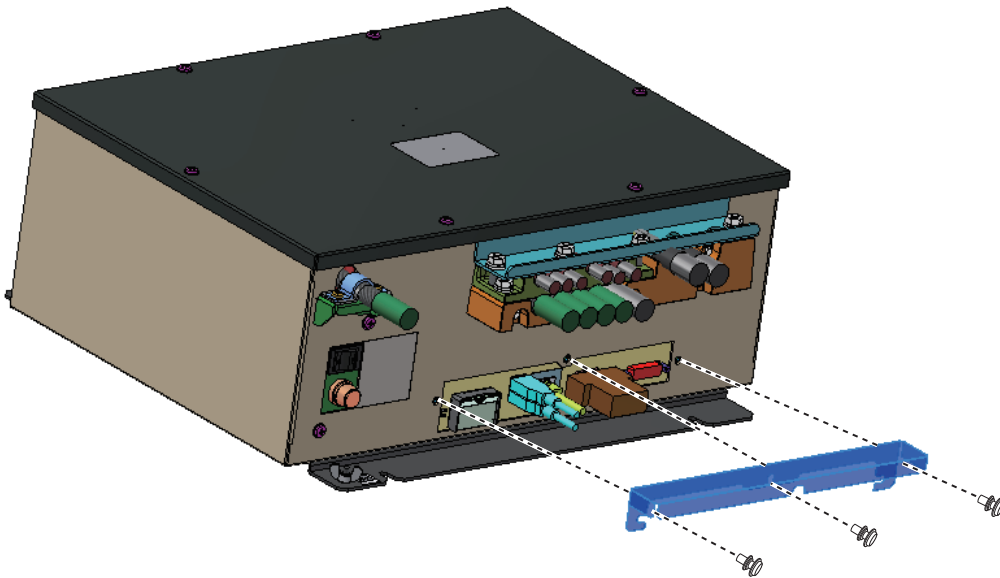

### How to attach the blind seal

Attach the blind seal over the hole on the rear side of the unit.

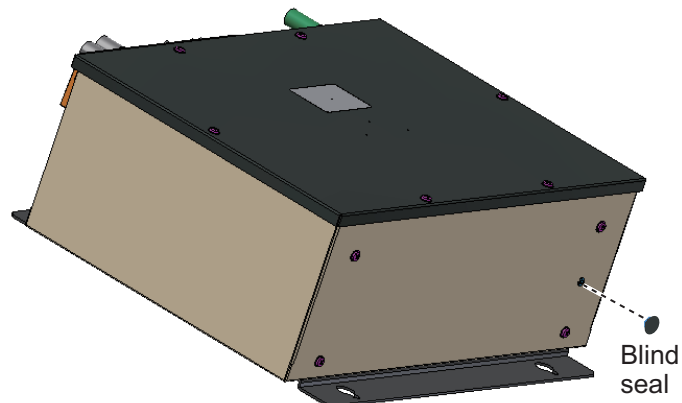

## 2.5 Trackball Control Unit

Connect the cable from the control unit to the cable on the trackball control unit. Cover the junction with heat shrink tubing, then heat. Cover the heat shrink tubing with vinyl tape.



Connect cables, cover junction with heat shrink tubing, then heat.

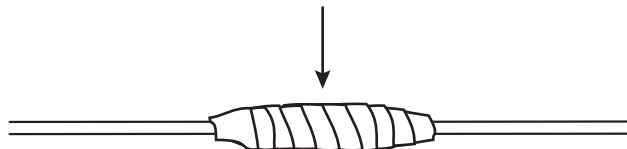

Cover with vinyl tape.

## 2.6 VDR Connection

The processor unit has an RGB port for connection of a VDR. Use the optional RGB cable (3COX-2P-6C 5m/10m) to connect the VDR.

### **About the RGB port**

- The RGB port and DVI port have their own circuits. This prevents interruption of the radar picture shown on the main monitor connected to the DVI port, if a fault condition occurs at the RGB port.
- The processor unit continuously outputs video signals from its DVI and RGB ports. The operator cannot stop the output.

## 2.7 Shuttle Ferry Mode

Shuttle ferry mode allows the user to change the screen orientation by 180°. This more requires an external switch (local supply and install) and the following connection must be made to the FRP\_TB board (03P9601) in the processor unit.

Connect a short-circuit switch to the 1/3 and 2/4 pins on the J609 connector on the FRP\_TB board (XN10P connector required, supplied locally), referring to the figure below.

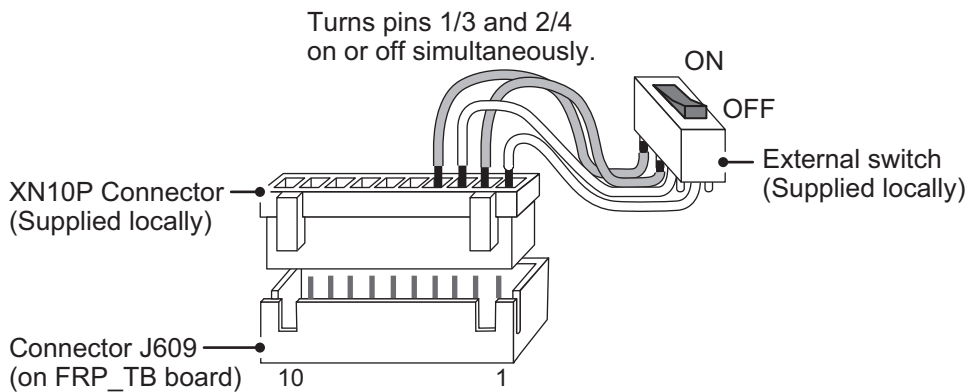

# 3. ADJUSTMENTS

**Note:** After completing the settings and adjustments, copy the setting data to a SD-card (SD card slot is at the back of the processor unit), referring to section 1.51 in the Operator's Manual. This will allow easy restoration of setting data after the SPU Board is replaced, etc.

At the first power up after installation, open the protected menus to adjust the radar. Follow the procedures in this chapter, in the order shown, to complete the adjustment.

Below are the controls on the control unit that are used to make the adjustments.

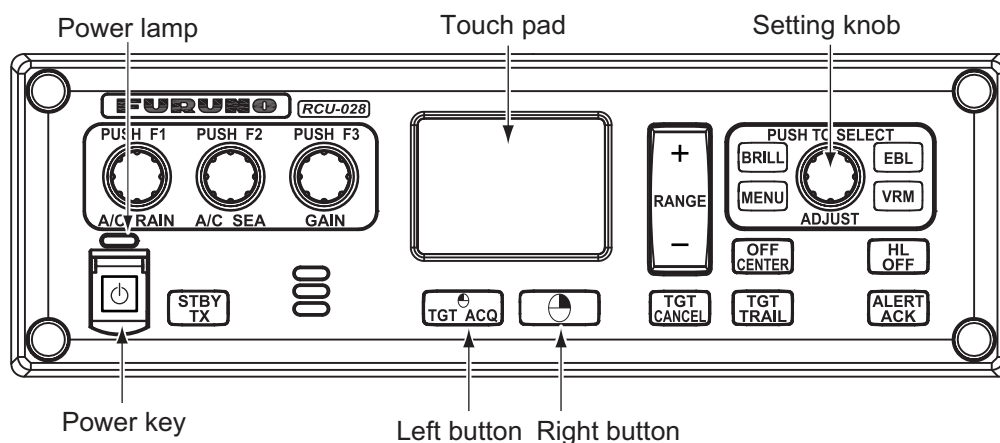

## 3.1 How to Open the Radar Installation Menu

The [RADAR INSTALLATION] menu has the items for adjustment of the radar. Do the following to access this menu.

1. Open the cover of the power switch and press the switch to turn on the radar.
2. Press the **MENU** key five times while pressing the **HL OFF** key to open the [RADAR INSTALLATION] menu.

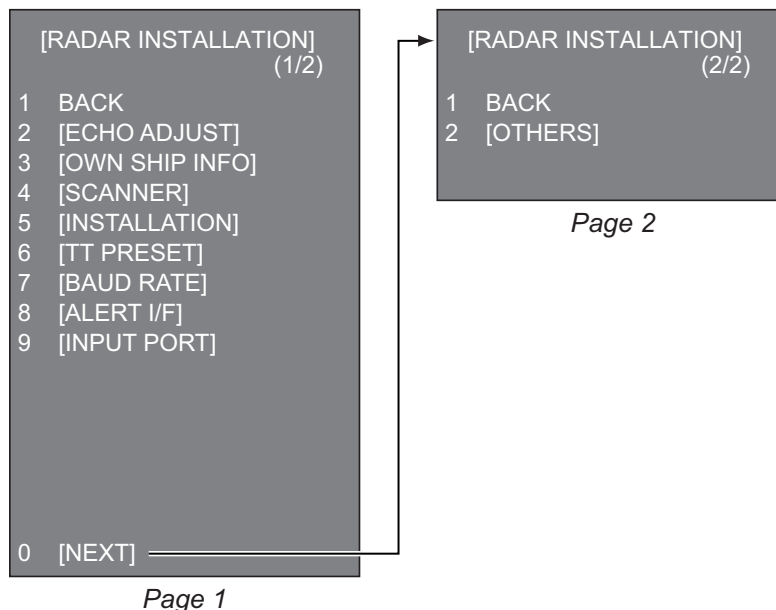

## 3.2 How to Use the Menu

1. Press the **MENU** key to open the main menu.

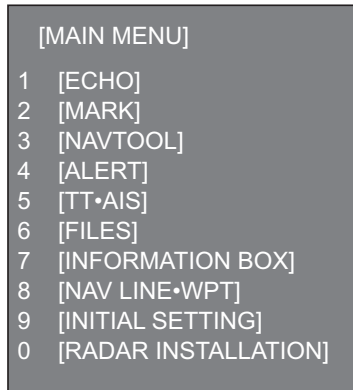

2. Operate the Setting knob to select a menu then push the knob.
3. Operate the Setting knob to select a menu item then push the knob.
4. Operate the Setting knob to select a menu option then push the knob.
5. If the menu option requires entry of numeric data, rotate the setting knob to set then push the knob. The knob can also be long-pushed to set a numeric. Each push increments the numeric by one.

## 3.3 How to Initialize Tuning

1. Open the main menu.
2. Open the [ECHO] menu.

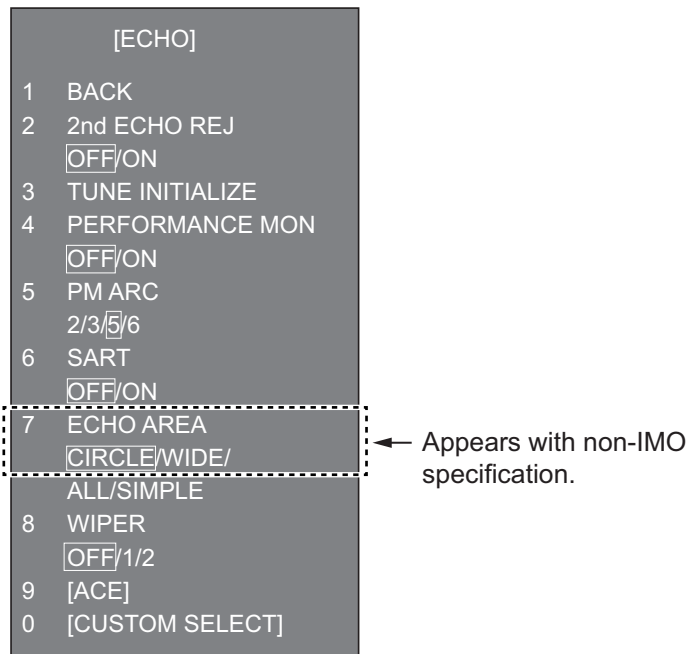

3. Select [TUNE INITIALIZE], then press the Left button.  
The indication "TUNE INITIALIZE" appears on the screen during the initialization.
4. After the tuning is completed, press the Right button twice to close the menu.

## 3.4 How to Align the Heading

You have mounted the antenna unit facing straight ahead in the direction of the bow. Therefore, a small but conspicuous target dead ahead visually should appear on the heading line (zero degrees). In practice, you will probably observe some small bearing error on the display because of the difficulty in achieving accurate initial positioning of the antenna unit. The following adjustment will compensate for this error.

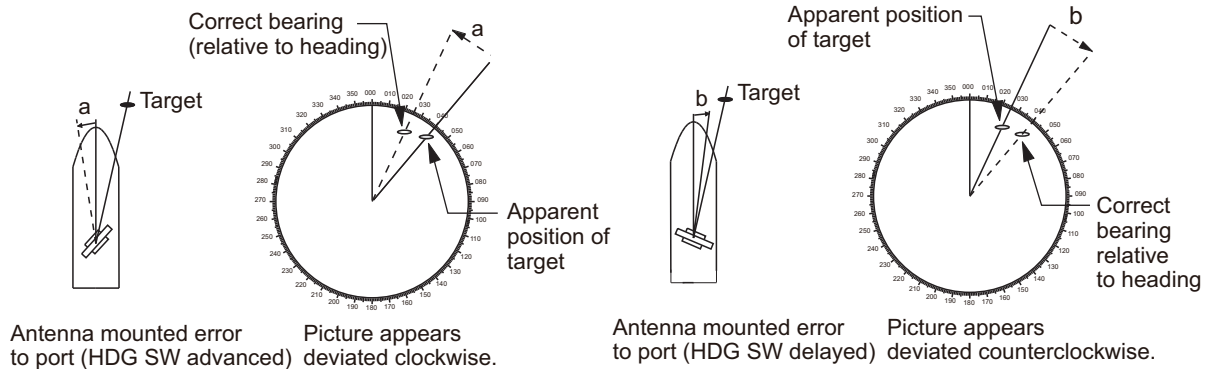

1. Select a stationary target echo at a range between 0.125 and 0.25 NM, preferably near the heading line.
2. Press the **EBL** key to turn on the EBL. Rotate the Setting knob to pass the EBL through the center of the target echo.
3. Read the target bearing.
4. Measure the bearing of the stationary target on the navigation chart and calculate the difference between the actual bearing and apparent bearing on the radar screen.
5. Open the [RADAR INSTALLATION] menu, then open the [ECHO ADJUST] menu.

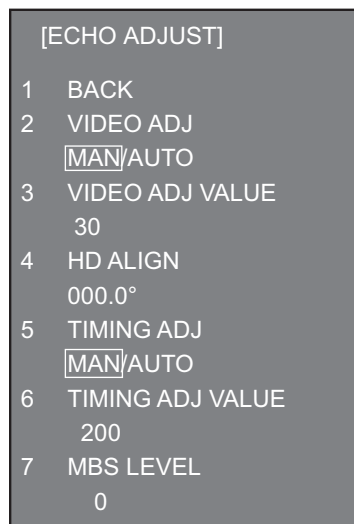

6. Select [HD ALIGN], then enter the bearing difference measured at step 4. The setting range is 0 to 359.9 degrees.
7. Confirm that the target echo is displayed at the correct bearing on the screen.

## 3.5 How to Adjust Sweep Timing

Sweep timing differs with respect to the length of the signal cable between the antenna unit and the processor unit. Adjust sweep timing at installation to prevent the following symptoms:

- The echo of a "straight" target (for example, pier), on the 0.25 NM range, will appear on the display as being pulled inward or pushed outward. See the figures below.

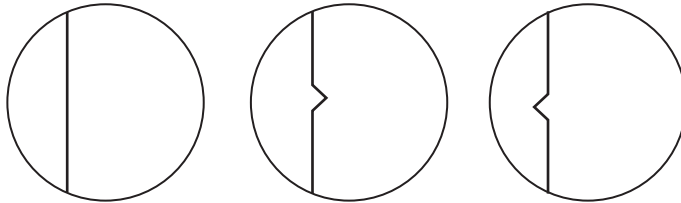

(1) Correct (2) Target pushed inward (3) Target pushed outward

- The range of target echoes is incorrect.
  1. Set the **GAIN**, **A/C SEA** and **A/C RAIN** controls as shown below.  
**GAIN:** 80  
**A/C SEA:** Fully counterclockwise (OFF)  
**A/C RAIN:** Fully counterclockwise (OFF)
  2. Open the [RADAR INSTALLATION] menu, then open the [ECHO ADJUST] menu.
  3. Set [TIMING ADJ] to [AUTO] to activate the automatic adjustment, which takes approx. two minutes.
  4. After the adjustment is completed, set the radar to the minimum range. Confirm that no echoes are "missing" at the center of the radar screen.  
If echoes are missing, set [TIMING ADJ] to [MAN]. Select [TIMING ADJ VALUE], then use the Setting knob to adjust the timing manually.

## 3.6 How to Suppress Main Bang

If main bang appears (a red ring at the screen center), suppress it as follows.

1. Transmit the radar on a long range and then wait 10 minutes.
2. Adjust the gain to show a slight amount of noise on the display.
3. Select the 0.125 NM range, then adjust the **A/C SEA** and **A/C RAIN** controls.
4. Go to the [RADAR INSTALLATION] menu, then open the [ECHO ADJUST] menu.
5. Select [MBS LEVEL], then use the Setting knob to enter a value that causes the main bang to faintly disappear. The setting range is 0 to 255.

## 3.7 RADAR INSTALLATION Menu

This section provides descriptions of the [RADAR INSTALLATION] menu items not previously mentioned.

### 3.7.1 OWN SHIP INFO menu

Enter the length and width of the ship, and scanner, GPS antenna and conning positions, referring to the description and figure below.

**Note:** This radar uses the CCRP=CONNING POSITION and ANT=SCANNER POSITION as the reference points for measurements and calculations. The commissioning engineer should understand this point, and enter own ship information accordingly.

[OWN SHIP INFO]	
1	BACK
2	LENGTH/WIDTH
	LENGTH 0m
	WIDTH 0m
3	SCANNER POSITION
	BOW 0m
	PORT 0m
4	GPS1 ANT POSITION
	BOW 0m
	PORT 0m
5	GPS2 ANT POSITION
	BOW 0m
	PORT 0m
6	CONNING POSITION
	BOW 0m
	PORT 0m

*Example*

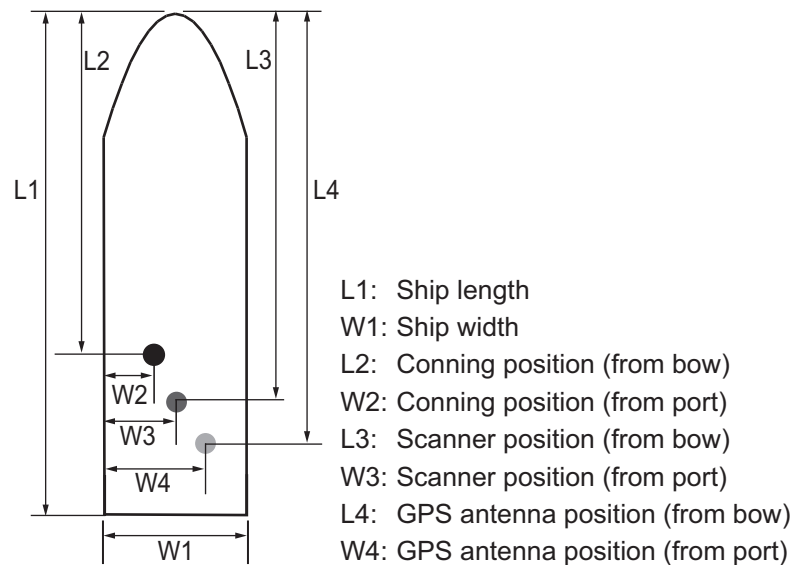

**[LENGTH/WIDTH]:** Enter the ship's length and width.

**[SCANNER POSITION]:** Enter the distance from the scanner to both bow and port.

**[GPS 1 ANT POSITION]:** Enter the distance from the GPS antenna to both bow and port. If a 2nd GPS antenna is installed, enter its position in [GPS 2 ANT POSITION].

**[CONNING POSITION]:** Enter the distance from the conning position to both bow and port.

### 3.7.2 INSTALLATION menu

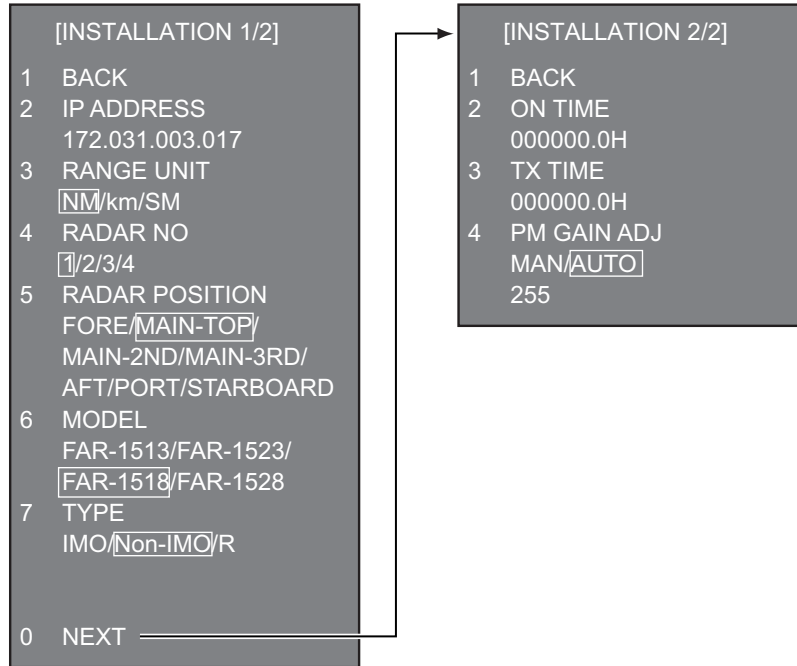

**[IP ADDRESS]:** Enter IP address. The default address is 172.031.003.017.

**[RANGE UNIT]:** Select the unit of range measurement, among [NM], [km], or [SM].

**[RADAR NO]:** Select the radar number - 1, 2, 3, or 4.

**[RADAR POSITION]:** Select the radar position. The choices are [FORE], [MAIN-TOP], [MAIN-2ND], [MAIN-3RD], [AFT], [PORT], and [STARBOARD].

**[MODEL]:** Select the model name - [FAR-1513], [FAR-1523], [FAR-1518], or [FAR-1528].

**[TYPE]:** Select the type of radar - [IMO], [Non-IMO] or [R].

**[ON TIME], [TX TIME]:** These items show the number of hours the radar has been turned on and transmitted, respectively. Value can be changed; for example, after replacing the magnetron. [TX TIME] can be reset to 0.

**[PM GAIN ADJ]:** Adjust the performance monitor gain, automatically or manually, whenever the magnetron is replaced.

To adjust the performance monitor gain, do as follows:

1. Select automatic or manual adjustment. For automatic adjustment, no further operation is required; close the menu at the completion of the adjustment. For manual go to the next step.
2. Set the radar controls as shown below.
  - Range:** 24 NM
  - Pulse Length:** Long
  - A/C SEA:** OFF (turn off manually)
  - A/C RAIN:** OFF (turn off manually)
  - Echo Averaging (EAV):** OFF
  - Video Contrast:** 2-B

3. Adjust the **GAIN** control so that a slight amount of white noise appears on the screen. Arcs for the performance monitor appear on the screen.
4. Select [PM GAIN ADJ]. Operate the Setting knob so that the outer arc faintly appears, then push the Right button to set.

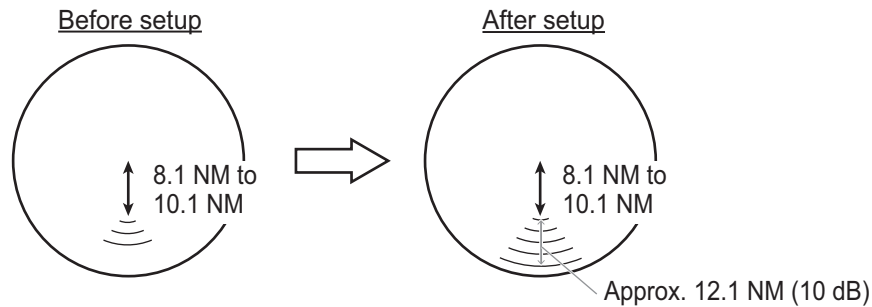

**Example:** [PM ARC] is set to [5]. (The location of arcs changes with the setting of [PM ARC] in [PERFORMANCE MON] in the [ECHO] menu.)

### 3.7.3 ECHO ADJUST menu

[VIDEO LEVEL ADJ]: Adjust the video level, automatically or manually. Set the radar as follows:

**Interference Rejector (IR):** 2

**Echo Stretch (ES):** OFF

**Echo Averaging (EAV):** OFF

**Gain:** 80

**Range:** 24 NM

**Pulse Length:** Long

For manual adjustment, select [VIDEO ADJ VALUE]. Rotate the Setting knob so that noise just disappears from the screen. The setting range is 0 to 73.

### 3.7.4 SCANNER menu

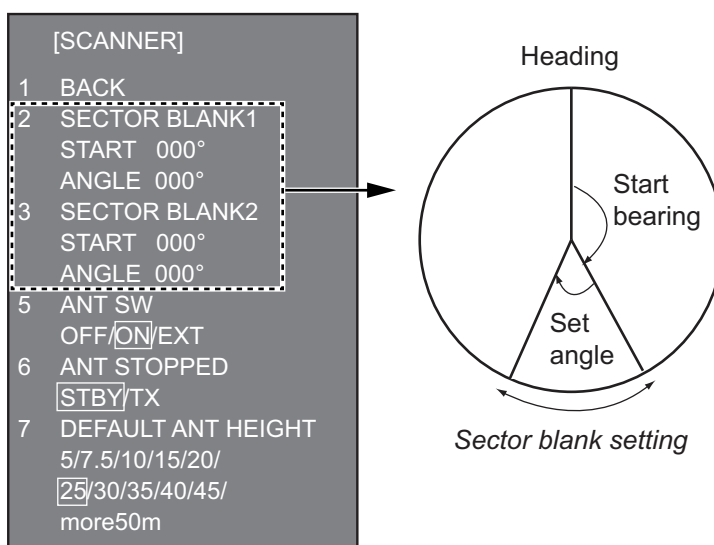

[SECTOR BLANK1], [SECTOR BLANK2]: Set area(s) where to prevent transmission. Heading must be properly aligned (see section 3.4) before setting any blind sector. For example, set the area where an interfering object at the rear of the antenna would produce a dead sector (area where no echoes appear) on the display. To enter

### 3. ADJUSTMENTS

an area, enter start bearing relative to the heading and dead sector angle. To erase the area, enter 0 for both the [START] and [ANGLE] sections. The setting range of [START] is 0° to 359° and [ANGLE] is 0° to 180°.

**Note:** Turn off a stern blind sector when adjusting the gain of the performance monitor, in order to display the echo from the performance monitor properly.

**[ANT STOPPED]:** For serviceman.

**Note:** Select [OFF] at [ANT SW] to prevent antenna rotation. [ANT STOPPED] disables transmission while the antenna is stopped in STBY.

**[ANT SW]:** Starts or stops antenna rotation..

Select [OFF] to stop antenna rotation.

Select [ON] to start antenna rotation.

**Note:** [EXT] is not used.

**[DEFAULT ANT HEIGHT]:** Select the height (in meters) of the radar antenna above the waterline.

#### 3.7.5 TT PRESET menu

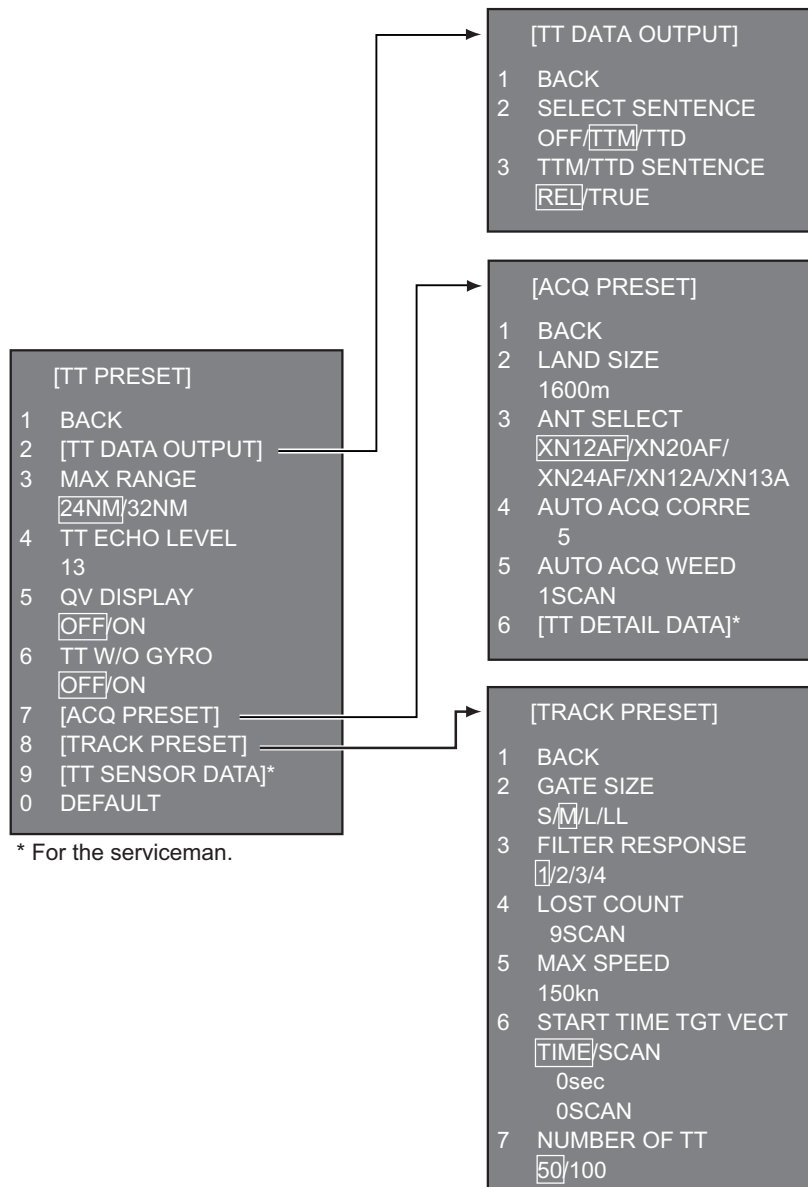

**[MAX RANGE]:** Select the maximum TT (target tracking) range, 24 or 32 NM.

**[TT ECHO LEVEL]:** Set the detection threshold level for TT echoes.

**[QV DISPLAY]:** [OFF]: Normal picture, [ON]: Quantized video. The normal picture is in effect whenever the power is turned on regardless of this setting.

**[TT W/O GYRO]:** Select [ON] to use TT without a gyro.

**[DEFAULT]:** Restore default settings for this menu.

#### **TT DATA OUTPUT menu**

**[SELECT SENTENCE]:** Select the target data sentence (TTM or TTD) to output. Select [OFF] for no output.

**[TTM/TTD REFERENCE]:** Select the output format (bearing) for the TTM/TTD sentence.

**[REL]** (Target bearing from own ship, degree relative, target course, degree relative), or **[TRUE]** (Target bearing, degree true, target course, degree true).

#### **ACQ PRESET menu**

**[LAND SIZE]:** Set the land size in units of 100 m. The setting range is 100 to 3000 m. A target whose length is equal to or greater than the length set here is judged as a land target.

**[ANT SELECT]:** Select the antenna radiator type of your radar. The size of the echo changes with radiator size. Select the correct radiator type to ensure proper performance.

**[AUTO ACQ CORRE]:** Set the correlation count for automatic acquisition. The setting range is 3 to 10.

**[AUTO ACQ WEED]:** Set the cancel count for automatic acquisition. The setting range is 1 to 5.

**[TT DETAIL DATA]:** For the service technician.

#### **TRACK PRESET menu**

**[GATE SIZE]:** Select the gate size - [S], [M], [L], or [LL].

**[FILTER RESPONSE]:** Set the filter response function. The setting range is 1 to 4.

1: Filter response is improved.

4: Filter stability is improved.

**[LOST COUNT]:** Set the number of scans to allow between the time a target is lost and is declared a lost target. The setting range is 1 to 20.

**[MAX SPEED]:** No use.

**[START TIME TGT VECT]:** Set the number of seconds or number of scans to wait before showing the vector for a newly acquired target. Select [TIME] or [SCAN] then enter value.

**[NUMBER OF TT]:** Select the maximum number of TT to track, 50 or 100.

#### **TT SENSOR DATA menu**

For the service technician.

### 3. ADJUSTMENTS

#### 3.7.6 BAUD RATE menu

Set the baud rate, 4800 or 38400 (bps), for connected equipment - heading sensor, AIS transponder, GPS navigator, Log, AMS, and ECDIS.

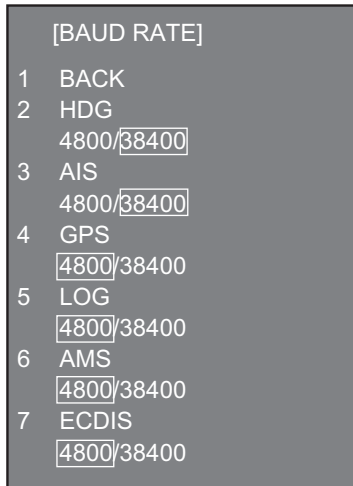

#### 3.7.7 ALERT I/F menu

Four alert contact outputs are available, [ALERT OUT1] - [ALERT OUT4]. Set each alert out referring to the description on the next page.

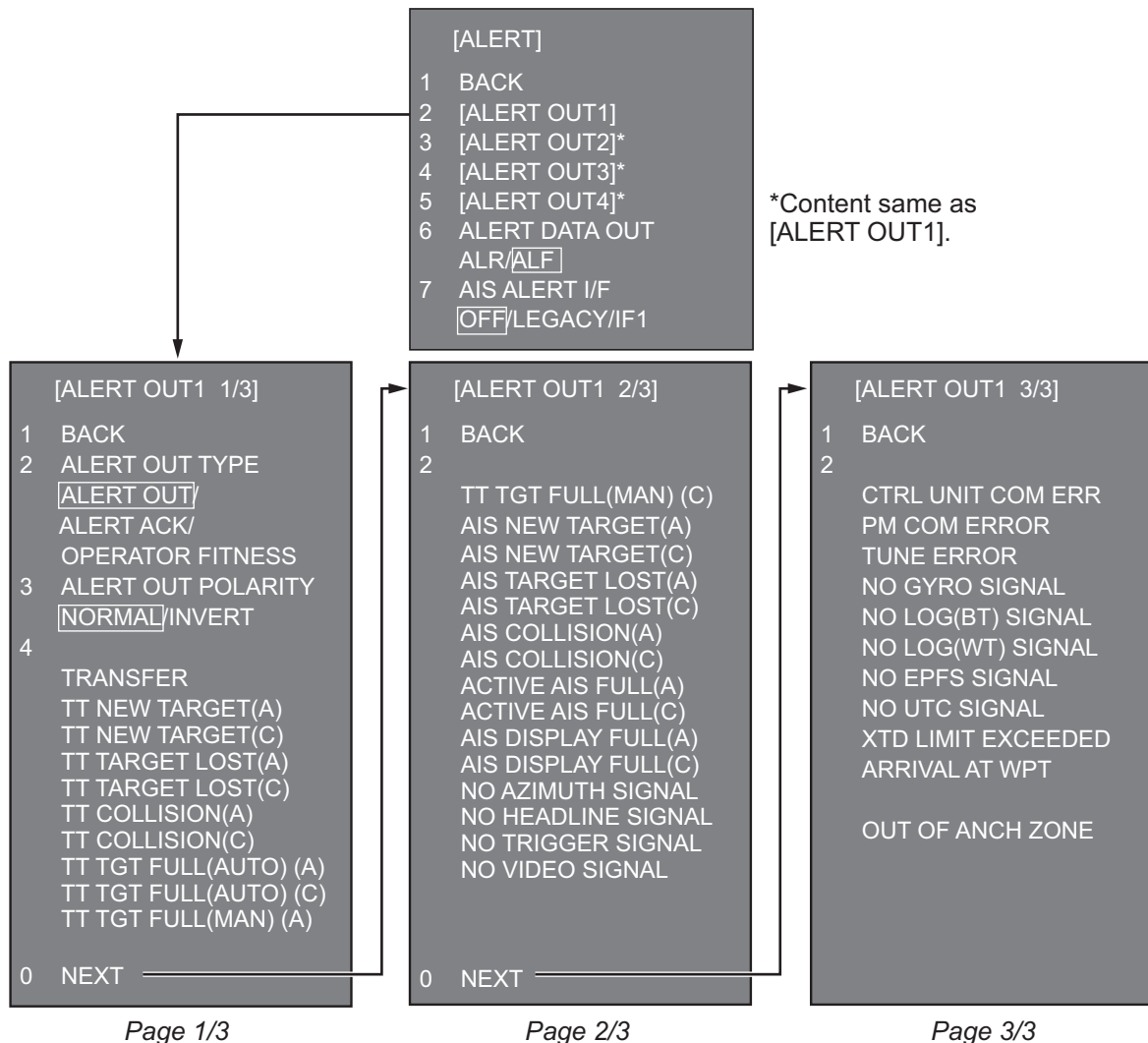

ALERT menu (main)

**[ALERT OUT 1] - [ALERT OUT 4]:** Select the alert to output for each alert out number. To monitor for unit failure if and when it occurs, set the alert contact outputs referring to the table below.

Unit	Alert
Transceiver unit	<ul style="list-style-type: none"> <li>• NO AZIMUTH SIGNAL</li> <li>• NO HEADLINE SIGNAL</li> <li>• NO TRIGGER SIGNAL</li> <li>• NO VIDEO SIGNAL</li> </ul>
Performance monitor	PM COM ERROR
Control unit	CTRL UNIT COM ERR

To monitor for processor unit failure, connect SYS\_FAIL and PWR\_FAIL from terminal J613 in the processor unit to the AMS.

**[ALERT DATA OUT]:** Select the alert output format, [ALR] (Set Alarm State) or [ALF] (Alert Sentence).

**[AIS ALERT I/F]:** Set the AIS alert interface. [OFF] does not output AIS alert.

[LEGACY]: For connection to FA-100, or connection to FA-150 where the AIS mode is LEGACY.

[IF1]: For connection to FA-150 where the AMS mode is AlertIF1.

## ALERT OUT sub menus

**[ALERT OUT TYPE]:** Select the alert out format, [ALERT OUT], [OPERATOR FITNESS] or [ALERT ACK].

**[ALERT OUT POLARITY]:** Select the alert out polarity, [NORMAL] or [INVERT].

**Note:** For category A alert, there are two types of output operations, “A” and “C”. To inform the AMS of category A alerts via contact signal, connect both “A” and “C” signals.

(A): Alert sound is output when the corresponding item is an unacknowledged alert. Output is stopped when the item is acknowledged.

(C): Alert sound is output when the corresponding item becomes an alert condition. Output is stopped when the alert condition is removed.

The table below shows the operational status of the alert outputs based on the output type.

Output type	Status			
	Normal	A new alert is raised	An existing alert is acknowledged	An existing alert condition becomes non-active
A	Off	On	Off	Off
C	Off	On	On	Off

### 3. ADJUSTMENTS

#### 3.7.8 INPUT PORT menu

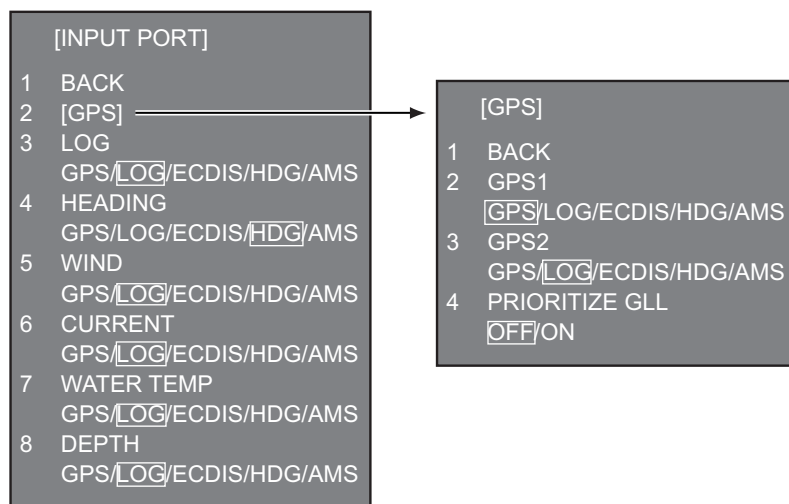

#### **INPUT PORT menu**

Select the source for LOG, GPS, HEADING, WIND, CURRENT, WATER TEMP, and DEPTH.

**[GPS]** (menu): Select the source for GPS navigator GPS1 and GPS2. [PRIORITYZE GLL], when turned on, gives priority to the GLL sentence.

**Note:** Do not set the same port for GPS1 and GPS2. For example, set GPS1 for the GPS port; GPS2 for any other port (ex. LOG).

**[LOG]:** Select the source for speed data.

**[HEADING]:** Select the source for heading data.

**[WIND]:** Select the source for wind data.

**[CURRENT]:** Select the source for current (tide) data.

**[WATER TEMP]:** Select the source for water temperature data.

**[DEPTH]:** Select the source for depth data.

### 3.7.9 OTHERS menu

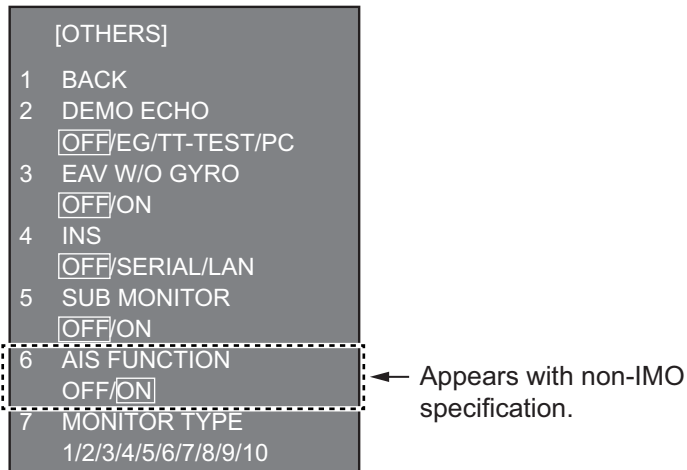

**[DEMO ECHO]:** Select the source for the demonstration echo, [EG] (Echo Generator), [TT-TEST] or [PC]. Select [OFF] to disable the demonstration echo feature.

**[EAV W/O GYRO]:** The each averaging feature can be used without a gyrocompass. Select [ON] to use the feature without a gyrocompass.

**[INS]:** Select the INS communication method, [SERIAL] or [LAN]. Select [OFF] for no INS connection.

**[SUB MONITOR]:** No use. Keep in the [OFF] setting.

**[AIS FUNCTION]:** Enable or disable the AIS function. (Available with non-IMO type only.)

**[SUB MONITOR]:** No use. Keep in the [OFF] setting.

**[MONITOR TYPE]:** For future use. Keep default setting ([1]).

## 3.8 Display Unit Setting

### 3.8.1 MU-150HD

#### How to turn the power on/off

The external equipment connected to the DVI port (DVI-D1 or DVI-D2) can power the display unit on/off.

#### Slide switch

- **ON (upward):** Allow the digital signal from external equipment to control the on/off of the display unit.
- **OFF (downward):** Set to this position for analog RGB signal.

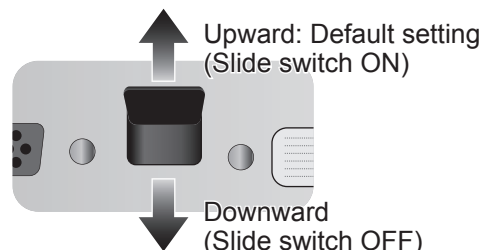

**Note:** Turn the slide switch OFF to connect equipment to both DVI and RGB ports.

#### How to adjust the brilliance from external equipment

You can set the brilliance control on the [SYSTEM] menu. Also, you can check the signal status and the program number on the [SYSTEM] menu.

1. Press the **MENU** key to show the main menu.
2. Press the **▶** key to select [SYSTEM]. The message "Input Signal Searching. Please Wait." appears and then the [SYSTEM] menu is displayed, as shown in the right figure.

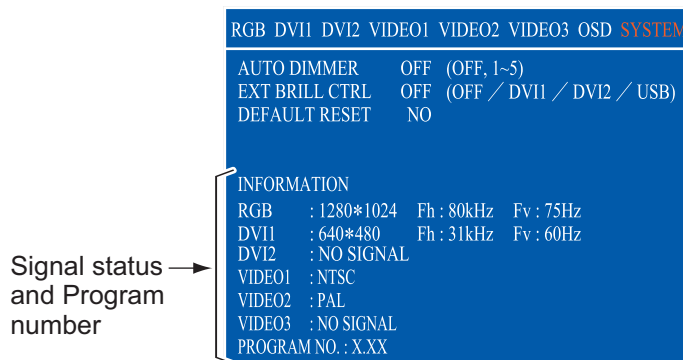

3. Press the **▲** or **▼** key to select [AUTO DIMMER]
4. Press the **◀** or **▶** key to select [OFF].
5. Press the **▲** or **▼** key to select [EXT BRIL CTRL].
6. Press the **◀** or **▶** key to select [DVI1] or [DVI2].
7. Press the **MENU** key to close the menu.

### How to lock the operation

You can lock the display unit to prevent operation. Any key (except the  /BRILL key) will be inoperative.

1. While you hold the **PIP** key, turn on the display unit. Press and hold the **PIP** key for more than five seconds.

**Note:** When the slide switch is "ON", turn on the connected external equipment while pressing the **PIP** key to turn on the display unit.

2. To cancel the lock, turn off the display unit and then turn it on while you hold the **PIP** key.

Press and hold the **PIP** key more than five seconds.

### 3.8.2 MU-190

The [INSTALLATION SETTING] menu appears only when the power is turned on for the first time after installation.

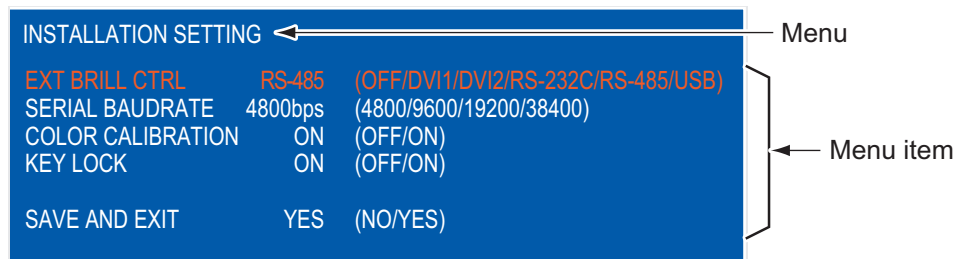

Connected equipment	Connected Unit	EXT BRILL CTRL	SERIAL BAUDRATE	COLOR CALIBRATION	KEY LOCK	DVI PWR SYNC*
FAR-15x3/ 15x8	RPU-024	DVI	-	OFF	ON	ON

\* "DVI PWR SYNC" is the slide switch at the bottom rear of the monitor unit. See the "Slide switch" below.

### Slide switch

Set the slide switch to "ON" (default setting). This setting automatically powers the monitor unit on or off according to the DVI signal input. The power switch of the monitor unit is inoperative.

**Note:** The OFF position provides control of the monitor unit power with the power switch of the monitor unit.

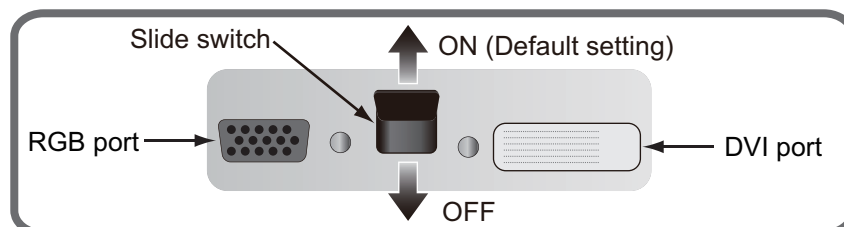

**How to open the INSTALLATION SETTING menu**

Turn off the monitor unit. While you hold the **DISP** key, press the **⏻/BRILL** key to turn on the monitor unit. Press and hold the **DISP** key for more than five seconds.

**Note:** When the "DVI PWR SYNC" slide switch is ON, turn on the connected external equipment while you press the **DISP** key to turn on the monitor unit.

**How to adjust the display aspect ratio**

1. Press the **MENU** key to show the menu. (The main menu automatically closes in 10 seconds if there is no operation.)
2. Press the **◀** or **▶** key to select [DVI1] or [DVI2]. The current setting (the cursor) is shown in orange. The menu items available depend on the menu selected. The menu items [DVI1] and [DVI2] have the same options.

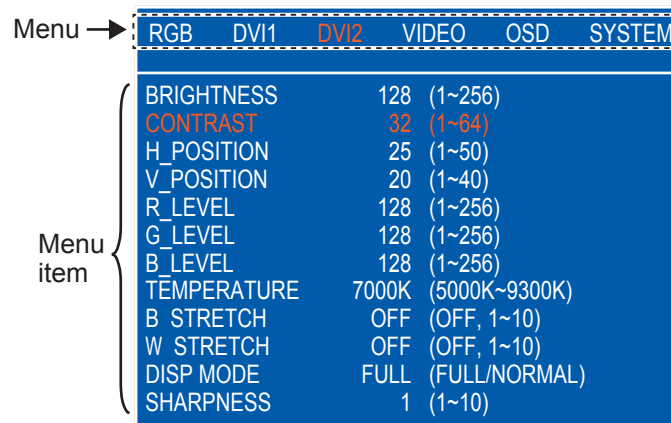

*DVI setting menu*

3. Press the **▲** or **▼** key to select [DISP MODE].
4. Press the **◀** or **▶** key to select [NORMAL].
5. Press the **MENU** key to close the menu.

# 4. INPUT/OUTPUT DATA

## Notice for FAR-1518(-BB)/FAR-1528(-BB)

These radars must be interconnected to the following type approved sensors:

- EPFS meeting the requirements of the IMO resolution MSC.112(73).
- Gyrocompass meeting the requirements of the IMO resolution A.424(XI).
- SDME meeting the requirements of the IMO resolution MSC.96(72).

## 4.1 Processor Unit

Input and output data handled at the processor unit are shown in the table below.

### Input

Data	Specification	Contents	Remarks
Heading signal	IEC 61162-2*		
Speed signal	IEC 61162-1 Ed.4		
Navaid data	IEC 61162-1 Ed.4	Position, time and date, datum, course, speed, wind, current, depth, temperature, Navtex, etc.	
AIS signal	IEC 61162-2		
Alarm handling signal	Contact closure		Input from alarm system
	IEC 61162-1 Ed.4		Input from alarm system

\* Data input cycle must be more than 40 Hz (high speed craft) or 20 Hz (conventional ships).

### Output

Data	Specification	Sentence	Remarks
Radar system data	IEC 61162-1 Ed.4	RSD, OSD	
TT data**	IEC 61162-1 Ed.4	TTD, TTM, TLB	
Alarm signal	IEC 61162-1 Ed.4		Four systems, output contents are selected on the [ALERT I/F] menu.
	Contact closure		

\*\* The output sentence can be set on the [TT DATA OUTPUT] menu (see page 3-9).

## 4.2 IEC 61162 Sentences

### Input sentence and sentence priority

Data	Sentence priority
Heading (true)	THS>HDT>HDG*>VHW*
Heading (magnetic)*	HDG>HDM>VHW
Magnetic deviation*	HDG
AIS target message, alert	VDM, VDO, ABK, ALR
Time and date	ZDA
Position	GNS>GGA>RMC>GLL
Datum	DTM
GNSS satellite malfunction detection	GBS
Course over the ground (COG)	VTG>RMC>VBW
Speed over the ground (SOG) (GPS)	VTG>RMC
Speed over the ground (LOG (BT))	VBW
Speed through the water (STW)	VBW>VHW
Alert	ACK, ACN, HBT
Waypoint	RMB>BWR>BWC>WPL
Route data	RTE+WPL
Wind speed and angle (true)	MWV>VWT
Wind speed and angle (relative)	MWV>VWR
Depth	DPT>DBT>DBS>DBK
Water temperature	MTW
Current	CUR, VDR

\* No use with IMO-type radar.

### Output sentences

Data	Sentence
AIS message, alert	ABM, BBM, ACK, VSD
Alert sentence	ALR, ALC, ALF, ARC, HBT
Operator fitness	EVE
Own ship data	OSD
Radar system data	RSD
Target data	TTM, TLB, TTD
Target L/L position	TLL

# APPENDIX 1 JIS CABLE GUIDE

Cables listed in the manual are usually shown as Japanese Industrial Standard (JIS). Use the following guide to locate an equivalent cable locally.

JIS cable names may have up to 6 alphabetical characters, followed by a dash and a numerical value (example: DPYC-2.5).

For core types D and T, the numerical designation indicates the *cross-sectional Area (mm<sup>2</sup>)* of the core wire(s) in the cable.

For core types M and TT, the numerical designation indicates the *number of core wires* in the cable.

## 1. Core Type

- D: Double core power line
- T: Triple core power line
- M: Multi core
- TT: Twisted pair communications  
(1Q=quad cable)

## 2. Insulation Type

- P: Ethylene Propylene Rubber

## 3. Sheath Type

- Y: PVC (Vinyl)

## 4. Armor Type

- C: Steel

## 5. Sheath Type

- Y: Anticorrosive vinyl sheath

## 6. Shielding Type

- S: All cores in one sheath
- S: Individually sheathed cores
- SLA: All cores in one shield, plastic tape w/aluminum tape
- SLA: Individually shielded cores, plastic tape w/aluminum tape



DPYCY



TPYCY

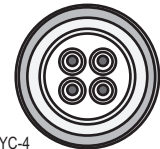

MPYC-4



TTYCSLA-4

EX: <sup>1 2 3 4 5 6</sup> **TTYCYSLA - 4**  
 Designation type | # of twisted pairs

EX: <sup>1 2 3 4</sup> **MPYC - 4**  
 Designation type | # of cores

The following reference table lists gives the measurements of JIS cables commonly used with Furuno products:

Type	Core		Cable Diameter	Type	Core		Cable Diameter
	Area	Diameter			Area	Diameter	
DPYC-1.5	1.5mm <sup>2</sup>	1.56mm	11.7mm	TTYCS-1	0.75mm <sup>2</sup>	1.11mm	10.1mm
DPYC-2.5	2.5mm <sup>2</sup>	2.01mm	12.8mm	TTYCS-1T	0.75mm <sup>2</sup>	1.11mm	10.6mm
DPYC-4	4.0mm <sup>2</sup>	2.55mm	13.9mm	TTYCS-1Q	0.75mm <sup>2</sup>	1.11mm	11.3mm
DPYC-6	6.0mm <sup>2</sup>	3.12mm	15.2mm	TTYCS-4	0.75mm <sup>2</sup>	1.11mm	16.3mm
DPYC-10	10.0mm <sup>2</sup>	4.05mm	17.1mm	TTYCSLA-1	0.75mm <sup>2</sup>	1.11mm	9.4mm
DPYCY-1.5	1.5mm <sup>2</sup>	1.56mm	13.7mm	TTYCSLA-1T	0.75mm <sup>2</sup>	1.11mm	10.1mm
DPYCY-2.5	2.5mm <sup>2</sup>	2.01mm	14.8mm	TTYCSLA-1Q	0.75mm <sup>2</sup>	1.11mm	10.8mm
DPYCY-4	4.0mm <sup>2</sup>	2.55mm	15.9mm	TTYCSLA-4	0.75mm <sup>2</sup>	1.11mm	15.7mm
MPYC-2	1.0mm <sup>2</sup>	1.29mm	10.0mm	TTYCY-1	0.75mm <sup>2</sup>	1.11mm	11.0mm
MPYC-4	1.0mm <sup>2</sup>	1.29mm	11.2mm	TTYCY-1T	0.75mm <sup>2</sup>	1.11mm	11.7mm
MPYC-7	1.0mm <sup>2</sup>	1.29mm	13.2mm	TTYCY-1Q	0.75mm <sup>2</sup>	1.11mm	12.6mm
MPYC-12	1.0mm <sup>2</sup>	1.29mm	16.8mm	TTYCY-4	0.75mm <sup>2</sup>	1.11mm	17.7mm
TPYC-1.5	1.5mm <sup>2</sup>	1.56mm	12.5mm	TTYCY-4S	0.75mm <sup>2</sup>	1.11mm	21.1mm
TPYC-2.5	2.5mm <sup>2</sup>	2.01mm	13.5mm	TTYCY-4SLA	0.75mm <sup>2</sup>	1.11mm	19.5mm
TPYC-4	4.0mm <sup>2</sup>	2.55mm	14.7mm	TTYCYS-1	0.75mm <sup>2</sup>	1.11mm	12.1mm
TPYCY-1.5	1.5mm <sup>2</sup>	1.56mm	14.5mm	TTYCYS-4	0.75mm <sup>2</sup>	1.11mm	18.5mm
TPYCY-2.5	2.5mm <sup>2</sup>	2.01mm	15.5mm	TTYCYSLA-1	0.75mm <sup>2</sup>	1.11mm	11.2mm
TPYCY-4	4.0mm <sup>2</sup>	2.55mm	16.9mm	TTYCYSLA-4	0.75mm <sup>2</sup>	1.11mm	17.9mm

# APPENDIX 2 DIGITAL INTERFACE

## Digital Interface

### Input sentence

ABK, ACK, ACN, ALR, BWC, BWR, CUR, DBK, DBS, DBT, DPT, DTM, GBS, GGA, GLL, GNS, HBT, HDG, HDM, HDT, MTW, MWV, RMB, RMC, RTE, THS, VBW, VDM, VDO, VDR, VHW, VSD, VTG, VWR, VWT, WPL, ZDA

### Output sentences

ABM, ACK, ALC, ALF, ALR, ARC, BBM, EVE, HBT, OSD, RSD, TLB, TLL, TTD, TTM, VSD

### Data reception

Data is received in serial asynchronous form in accordance with the standard referenced in IEC 61162-2 or IEC 61162-1 Ed.4.

The following parameters are used:

Baud rate: 38,400 bps (HDT, THS, !AIVDM, !AIVDO, !AIABK, \$IALR. The baud rate of all other sentences is 4800 bps

Data bits: 8 (D7=0), Parity: none, Stop bits: 1

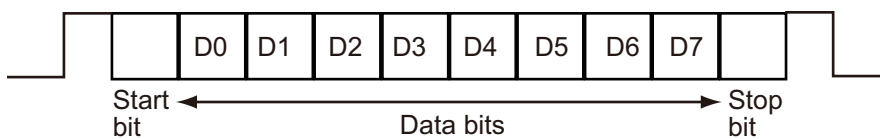

## Data Sentences

### Input sentences

ABK - UAIS Addressed and binary broadcast acknowledgment

```
$**ABK,xxxxxxxx,x,x,x,x,x,*hh<CR><LF>  
1 2 3 4 5
```

1. MMSI of the addressed AIS unit (9 digits) (No use)
2. AIS channel of reception (No use)
3. Message ID (6, 8, 12, 14) (No use)
4. Message sequence number (0 - 9) (No use)
5. Type of acknowledgement (See below)
  - 0 = message (6 or 12) successfully received by the addressed AIS unit
  - 1 = message (6 or 12) was broadcast, but not ACK by addressed AIS unit
  - 2 = message could not be broadcast (quantity of encapsulated data exceeds five slots)
  - 3 = requested broadcast of message (8, 14 or 15) has been successfully completed
  - 4 = late reception of message (7 or 13) ACK that was addressed to this AIS unit (own ship) and referenced a valid transaction
  - 5 = message has been read and acknowledged on a display unit.

ACK - Acknowledge alarm

```
$**ACK,xxx,*hh<CR><LF>  
1
```

1. Local alarm number (identifier) (001 - 999)

**ACN - Alert command**

\$\*\*ACN,hhmmss.ss,aaa,x.x,x.x,ca,a\*hh<CR><LF>  
           1      2  3  4  5  6

1. Time (hh=00 - 23, mm=00 - 59, ss.ss=00.00 - 60.99) (No use)
2. Manufacturer mnemonic code (3 digit alphanumeric code), null
3. Alert identifier (10001 - 10999)
4. Alert instance (null)
5. Alert command (A/Q/O/S)  
     A=ACK from ext. equipment,  
     Q=Request from ext. equipment  
     O=Responsibility transfer  
     S=Silence from ext. equipment
6. Sentence status flag (C)  
     (C should not be null field. Sentence without C is not a command.)

**ALR - Set alarm state**

\$\*\*ALR,hhmmss.ss,xxx,A,A,c—c,\*hh<CR><LF>  
           1      2  3  4  5

1. Time of alarm condition change, UTC (No use)
2. Unique alarm number (identifier) at alarm source (001 - 999)
3. Alarm condition (A/V)  
     A=threshold exceeded  V=not exceeded
4. Alarm acknowledge state (A/V)  
     A=acknowledged  V=not acknowledged
5. Alarm description text (alphanumeric characters, max. 32)

**BWC - Bearing and distance to waypoint - great circle**

\$\*\*BWC,hhmmss.ss,IIII.II, a,IIII.II,a,yyy.y,T, yyy.y,M,yyy.y,N,c--c,A,\*hh<CR><LF>  
           1      2  3  4  5  6  7  8  9  10  11  12  13

1. UTC of observation (No use)
2. Waypoint latitude (0000.00000 - 9000.00000)
3. N/S (N/S)
4. Waypoint longitude (00000.00000 - 18000.00000)
5. E/W (E/W)
6. Bearing, degrees true (No use)
7. Unit, True (No use)
8. Bearing, degrees (No use)
9. Unit, Magnetic (No use)
10. Distance, nautical miles (No use)
11. Unit, N (No use)
12. Waypoint ID (Max. 15 characters)
13. Mode Indicator (A/D)  
     A=Autonomous  
     D=Differential  
     E=Estimated (dead reckoning) mode  
     S=Simulator  
     N=Data not valid



**DBT - Depth below transducer**

\$\*\*DBT,xxx.x,f,xxx.x,M,xxx.x,F<CR><LF>  
 1 2 3 4 5 6

1. Water depth (0.00 - 99999.994)
2. f = feet (fixed)
3. Water depth (0.00 - 99999.994)
4. M = Meters (fixed)
5. Water depth (0.00 - 99999.994)
6. F = Fathom (fixed)

**DPT - Depth**

\$\*\*DPT,x.x,x.x,x.x,\*hh<CR><LF>  
 1 2 3

1. Water depth relative to the transducer, meters (0.00-99999.994)
2. Offset from transducer, meters (IMO: -99.994 - 99.994,  
 Other than IMO: -99.994 - 99.994, null)
3. Minimum range scale in use (No use)

**DTM - Datum reference**

\$\*\*DTM,ccc,a,x.x,a,x.x,a,x.x,ccc,\*hh<CR><LF>  
 1 2 3 4 5 6 7 8

1. Local datum (W84/W72/S85/P90)  
 W84=WGS84 W72=WGS72 S85=SGS85 P90=PE90
2. Local datum subdivision code (No use)
3. Lat offset, min (No use)
4. N/S (No use)
5. Lon offset, min (No use)
6. E/W (No use)
7. Altitude offset, meters (No use)
8. Reference datum (No use)

**GBS - GNSS satellite fault detection**

\$\*\*GBS, hhhmss.ss, x.x, x.x, x.x, xx, x.x, x.x, x.x,hh\*hh<CR><LF>  
 1 2 3 4 5 6 7 8 9 10

1. UTC time of GGA or GNS fix associated with this sentence (No use)
2. Expected error in latitude (0.0 - 999.9)
3. Expected error in longitude (0.0 - 999.9)
4. Expected error in altitude (No use)
5. ID number of most likely failed satellite (No use)
6. Probability of missed detection for most likely failed satellite (No use)
7. Estimate of bias in meters on most likely failed satellite (No use)
8. Standard deviation of bias estimate (No use)
9. GNSS Signal ID (No use)
10. GNSS System ID (No use)

## APPENDIX 2 DIGITAL INTERFACE

### GGA - Global positioning system fix data

```
$**GGA,hhmmss.ss,lll.lll,a,yyyyy.yyy,a,x,xx,x.x,x.x,M,x.x,M,x.x,xxxx,*hh<CR><LF>  
      1      2 3      4      5 6 7 8 9 10 11 12 13 14
```

1. UTC of position (no use)
2. Latitude (0000.00000 - 9000.00000)
3. N/S (N/S)
4. Longitude (0000.00000 - 18000.00000)
5. E/W (E/W)
6. GPS quality indicator (1 - 8)
  - 0 = fix not available or invalid
  - 1 = GPS SPS mode
  - 2 = differential GPS, SPS mode
  - 3 = GPS PPS mode
  - 4 = Real Time Kinematic. Satellite system used in RTK mode with fixed integers
  - 5 = Float RTK. Satellite system used in RTK mode with floating solution
  - 6 = Estimated (dead reckoning) mode
  - 7 = Manual input mode
  - 8 = Simulator mode
7. Number of satellite in use (No use)
8. Horizontal dilution of precision (0.0 - 999.9)
9. Antenna altitude above/below mean sea level (No use)
10. Unit, m (No use)
11. Geoidal separation (No use)
12. Unit, m (No use)
13. Age of differential GPS data (0 - 999, null)
14. Differential reference station ID (No use)

### GLL - Geographic position, latitude/longitude

```
$**GLL,lll.lll,a,yyyyy.yyy,a,hhmmss.ss,A,a,*hh<CR><LF>  
      1 2      3      4      5      6 7
```

1. Latitude (0000.00000 - 9000.00000)
2. N/S (N/S)
3. Longitude (0000.00000 - 18000.00000)
4. E/W (E/W)
5. UTC of position (No use)
6. Status (A)
  - A=data valid V=data invalid
7. Mode indicator (A/D/E/M/S)
  - A=Autonomous D=Differential E=Estimated M=Manual input S=Simulator N=Data not valid

### GNS - GNSS fix data

```
$**GNS,hhmmss.ss,lll.lll,a,llll.lll,a,c--c,xx,x.x,x.x,x.x,x.x,x.x,x.x,a*hh<CR><LF>  
      1      2 3      4      5 6      7 8 9 10 11 12 13
```

1. UTC of position (No use)
2. Latitude (0000.00000 - 9000.00000)
3. N/S (N/S)
4. Longitude (0000.00000 - 18000.00000)
5. E/W (E/W)
6. Mode indicator (A/D/P/R/F/E/M/S)
  - N=No fix A=Autonomous D=Differential P=Precise R=Real Time Kinematic
  - F=Float RTK E=Estimated Mode M=Manual Input Mode S=Simulator Mode
7. Total number of satellites in use (No use)
8. HDOP (0.00 - 999.99)
9. Antenna altitude, meters (No use)
10. Geoidal separation, meters (No use)
11. Age of differential data (0 - 999)
12. Differential reference station ID (No use)
13. Navigational status indicator(S/C/U/V, null)
  - S=Safe, C=Caution, U=Unsafe, V=Not valid

**HBT - Heartbeat supervision sentence**

\$\*\*HBT,x.x,A,x\*hh<CR><LF>  
1 2 3

1. Configured repeat interval (1 - 999, null)
2. Equipment status (No use)
3. Sequential sequence identifier (0 - 9)

**HDG - Heading, deviation and variation**

\$\*\*HDG,x.x,x.x,a,x.x,a\*hh<CR><LF> \*No use for  
1 2 3 4 5 Type-IMO

1. Magnetic sensor heading, degrees (0.00 - 360.00)
2. Magnetic deviation, degrees (0.00 - 180.00)
3. E/W
4. Magnetic variation, degrees (0.00 - 180.00)
5. E/W

**HDM - Heading, magnetic**

\$\*\*HDM,x.x,M\*hh<CR><LF> \*No use for  
1 2 Type-IMO

1. Heading, degrees (0.00 - 360.00)
2. Magnetic (M)

**HDT - Heading, true**

\$\*\*HDT,xxx.x,T\*hh<CR><LF>  
1 2

1. Heading, degrees (0.00 - 360.00)
2. True (T)

**MTW - Water temperature**

\$\*\*MTW,x.x,C<CR><LF>  
1 2

1. Water temperature (-9.994 - 99.994)
2. C=degrees C (fixed)

**MWV - Wind speed and angle**

\$\*\*MWV,x.x,a,x.x,a,A\*hh<CR><LF>  
1 2 3 4 5

1. Wind angle, degrees (0.00 - 360.00)
2. Reference (R/T)
3. Wind speed (0.00 - 9999.94)
4. Wind speed units (K/M/N/S)  
K=km/h M=m/s N=Knots S=Statute mile
5. Status (A)

## APPENDIX 2 DIGITAL INTERFACE

### RMB - Recommended minimum specific navigation information

```
**RMB,A,x.x,a,CCCC,CCCC,IIII.II,a,yyyy.yy,a,x.x,x.x,x.x,A,a*hh <CR><LF>  
  1  2  3  4      5  6  7  8  9 10 11 12 13 14
```

1. Data status (A)  
A=Data valid, V=Navigation receiver warning
2. Cross track error (NM) (No use)
3. Direction to steer (L/R) (No use)
4. Origin waypoint ID (No use)
5. Destination waypoint ID (Max. 15 characters)
6. Destination waypoint latitude (0000.00000 - 9000.00000)
7. N/S
8. Destination waypoint longitude (0000.00000 - 18000.00000)
9. E/W
10. Range to destination, nautical miles (No use)
11. Bearing to destination, degrees true (No use)
12. Destination closing velocity, knots (No use)
13. Arrival status (No use)
14. Mode indicator (A/D)  
A=Autonomous mode; D=Differential mode; E=Estimated (dead reckoning) mode;  
M=Manual input mode; S=Simulator mode; N=Data not valid

### RMC - Recommended minimum specific GPS/TRANSIT data

```
**RMC,hhmmss.ss,A,IIII.II,a,yyyy.yy,a,x.x,x.x,xxxxxx,x.x,a,a*hh <CR><LF>  
  1    2  3  4  5    6  7  8  9    10 11 12 13
```

1. UTC of position fix (No use)
2. Status (A)  
A=data valid, V=navigation receiver warning
3. Latitude (0000.00000 - 9000.00000)
4. N/S (N/S)
5. Longitude (00000.00000 - 18000.00000)
6. E/W (E/W)
7. Speed over ground, knots (0.00 - 9999.94)
8. Course over ground, degrees true (0.00 - 360.0)
9. Date (No use)
10. Magnetic variation, degrees (No use)
11. E/W (No use)
12. Mode indicator (A/D/E/M/S/F/P/R)  
A=Autonomous. Satellite system used in non-differential mode in position fix;  
D=Differential. Satellite system used in differential mode in position fix;  
E=Estimated (dead reckoning) mode;  
F=Float RTK. Satellite system used in real time kinematic mode with floating integers;  
M=Manual input mode;  
N=No fix. Satellite system not used in position fix, or fix not valid;  
P=Precise. Satellite system used in precision mode. Precision mode is defined as: no deliberate degradation (such as selective availability) and higher resolution code (P-code) is used to compute position fix. P is also used for satellite system used in multi-frequency, SBAS or Precise Point Positioning (PPP) mode;  
R=Real time kinematic. Satellite system used in RTK mode with fixed integers;  
S=Simulator mode
13. Navigational status indication (S/C/U/V, null)  
S=Safe, C=Caution, U=Unsafe, V=Not valid

**RTE - Routes**

\$\*\*RTE,x.x,x.x,a,c--c,c--c,...,c--c\*hh <CR><LF>

1 2 3 4 5 ... 6

1. Total number of sentences being transmitted (1 - 500, null)
2. Sentence number (1 - 500, null)
3. Sentence mode (C/W)  
C=Complete route, all waypoints W=Working route, first listed
4. Route identifier (alphabet or null)
5. Waypoint identifier (alphabet or null)
6. Waypoint "n" identifier (alphabet or null)

**THS - True heading and status**

\$\*\*THS,x.x,a\*hh<CR><LF>

1 2

1. Heading, degrees True (0.00 to 360.00)
2. Mode indicator(A/E)  
A=Autonomous; E=Estimated; M=Manual; S=Simulator; V=Data not valid

**VBW - Dual ground/water speed**

\$\*\*VBW,x.x,x.x,a,x.x,x.x,a,x.x,x.x,a,\*hh<CR><LF>

1 2 3 4 5 6 7 8 9 10

1. Longitudinal water speed, knots (-9999.994 - 9999.994)
2. Transverse water speed, knots (-9999.994 - 9999.994, null)
3. Status: water speed, A=data valid V=data invalid (A)
4. Longitudinal ground speed, knots (-9999.994 - 9999.994)
5. Transverse ground speed, knots (-9999.994 - 9999.994, null)
6. Status: ground speed, A=data valid V=data invalid (A)
7. Stern transverse water speed, knots (No use)
8. Status: stern water speed, A=data valid V=data invalid (No use)
9. Stern transverse ground speed, knots (No use)
10. Status: stern ground speed, A=data valid V=data invalid (No use)

**VDM - UAIS VHF data-link message**

!VDM,x,x,x,a,s--s,x,\*hh<CR><LF>

1 2 3 4 5 6

1. Total number of sentences needed to transfer the message (1 - 9)
2. Sentence number (1 - 9)
3. Sequential message identifier (0 - 9, null)
4. AIS channel number (A/B, null)
5. Encapsulated ITU-R M.1371 radio message (1 - 63 bytes)
6. Number of fill-bits (0 - 5)

**VDO - UAIS VHFG data-link own vessel report**

!VDO,x,x,x,a,s--s,x,\*hh<CR><LF>

1 2 3 4 5 6

1. Total number of sentences needed to transfer the message (1 - 9)
2. Sentence number (1 - 9)
3. Sequential message identifier (0 - 9, null)
4. AIS channel Number (A/B, null)
5. Encapsulated ITU-R M.1371 radio message (1 - 63 bytes)
6. Number of fill-bits (0 - 5)

## APPENDIX 2 DIGITAL INTERFACE

### VDR - Set and drift

\$\*\*VDR,x.x,T,x.x,M,x.x,N,\*hh <CR><LF>  
1 2 3 4 5 6

1. Direction, degrees (0.00 - 360.00, null)
2. T=True (fixed)
3. Direction, degrees Magnetic (No use)
4. M=Magnetic (No use)
5. Current speed (0 - 99.94)
6. N=Knots (fixed)

### VHW - Water speed and headings

\$\*\*VHW,x.x,T,x.x,M,x.x,N,x.x,K,\*hh <CR><LF>  
1 2 3 4 5 6 7 8

1. Heading, degrees (0.00 - 360.00)
2. T=True (fixed)
3. Heading, degrees (0.00 - 360.00)
4. M=Magnetic (fixed)
5. Speed, knots (0.00 - 999.94)
6. N=Knots (fixed)
7. Speed, knots (0.00 - 999.94)
8. K=km/hr (fixed)

### VSD - UAIS Voyage static data

\$--VSD,x.x,x.x,x.x,c--c,hhmmss.ss,xx,xx,x.x,x.x\*hh<CR><LF>  
1 2 3 4 5 6 7 8 9

1. Type of ship and cargo category (No use)
2. Maximum present static draught (No use)
3. Persons on-board (0 - 8191, null)
4. Destination (No use)
5. Estimated UTC of arrival at destination (No use)
6. Estimated day of arrival at destination (No use)
7. Estimated month of arrival at destination (No use)
8. Navigational status (No use)
9. Regional application flags (No use)

### VTG - Course over ground and ground speed

\$\*\*VTG,x.x,T,x.x,M,x.x,N,x.x,K,a,\*hh <CR><LF>  
1 2 3 4 5 6 7 8 9

1. Course over ground, degrees (0.00 - 360.00)
2. T=True (fixed)
3. Course over ground, degrees (No use)
4. M=Magnetic (No use)
5. Speed over ground, knots (0.00 - 9999.94)
6. N=Knots (fixed)
7. Speed over ground (0.00 - 9999.94)
8. K=km/h (fixed)
9. Mode indicator (A/D/E/M/P/S)  
A=Autonomous mode;  
D=Differential mode;  
E=Estimated (dead reckoning) mode;  
M=Manual input mode;  
P=Precise. Satellite system used in precision mode. Precision mode is defined as: no deliberate degradation (such as selective availability) and higher resolution code (P-code) is used to compute position fix. P is also used for satellite system used in multi-frequency, SBAS or Precise Point Positioning (PPP) mode;  
S=Simulator mode;  
N=Data not valid

**VWR - Wind relative bearing and velocity**

\$\*\*VWR,x.x,a,x.x,N,x.x,M,x.x,K<CR><LF>  
 1 2 3 4 5 6 7 8

1. Measured wind angle relative to the vessel, degrees (0.00 to 180.00)
2. Left/Right of vessel heading (L/R)  
 L=Left semicircle, R=Right semicircle
3. Velocity, knots (0.00 - 999.94)
4. N=Knots (fixed)
5. Velocity (0.00 - 999.94)
6. M=m/s (fixed)
7. Velocity, km/h(0.00 - 999.94)
8. K=km/h (fixed)

**VWT - True wind speed and angle**

\$\*\*VWT,xxx,a,xx.x,N,xx.x,M,xxx.x,K<CR><LF>  
 1 2 3 4 5 6 7 8

1. Measured wind angle relative to the vessel, degrees (0.00 - 180.00)
2. Left/Right of vessel heading (L/R)  
 L=Left semicircle, R=Right semicircle
3. Calculated wind speed kn (0.00 - 999.94)
4. N=Knots (fixed)
5. Wind speed m/s (0.00 - 999.94)
6. M=m/s (fixed)
7. Velocity, km/h (0.00 - 999.94)
8. K=km/h (fixed)

**WPL - Waypoint location**

\$\*\*WPL,IIII.II,a,yyyyy.yy,a,c--c\*hh<CR><LF>  
 1 2 3 4 5

1. Waypoint latitude (0000.00000 - 9000.00000)
2. N/S (N/S)
3. Waypoint longitude (00000.00000 - 18000.00000)
4. E/W (E/W)
5. Waypoint identifier (alphanumeric characters)

**ZDA - Time and date**

\$\*\*ZDA,hhmmss,xx,xx,xxxx,xx,xx<CR><LF>  
 1 2 3 4 5 6

1. UTC (000000.00 - 2400001.00)
2. Day (01 - 31)
3. Month (01 -12)
4. Year (0000-9999)
5. Local zone, hours (No use)
6. Loca zone, minutes (No use)

**Output sentences**

For ACK, see input sentences.

**ABM - AIS addressed binary and safety related message**

! \*\*ABM,x,x,x,xxxxxxxx,x,xx,s--s,x,\*hh<CR><LF>  
 1 2 3 4 5 6 7 8

1. Total number of sentences needed to transfer the message (1 - 9)
2. Sentence number (1 - 9)
3. Sequential message identifier (0 - 3)
4. The MMSI of destination AIS unit for the ITU-R M.1371 message (9 digits / null)
5. AIS channel for broadcast of the radio message (0 - 3 / null)
6. VDL message number (6 / 12 / null), see ITU-R M.1371
7. Encapsulated data (1 - 63 bytes)
8. Number of fill-bits (0 - 5)

**ALC - Cyclic alert list**

\$ \*\*ALC,xx,xx,xx,xx,aaa,x.x,x.x,x.x,"",\*hh<CR><LF>  
 1 2 3 4 5 6 7 8 9

1. Total number of sentences this message (01 - 16)
2. Sentence number (01 - 16)
3. Sequential message identifier (00 - 99)
4. Number of alert entries (0 - 3)
5. Manufacturer mnemonic code (FEC, null) \_\_\_\_\_
6. Alert identifier (1 - 999 or 10001 - 10999) \_\_\_\_\_
7. Alert instance (null) \_\_\_\_\_
8. Revision counter (1 - 99) \_\_\_\_\_
9. Additional alert entries (see Note)

Alert entry 1  
 See Note

Note: Alert entry 0 - n: Each alert entry consists of

- Manufacturer Identifier (see ALF Manufacturer
- Alert Identifier (see ALF Alert identifier)
- Alert instance (see ALF instance)
- Revision counter (see ALF revision counter)

Each entry identifies a certain alert with a certain state.

It is not allowed that an alert entry is split between two ALC sentences.

**ALF - Alert sentence**

\$ \*\*ALF,x,x,x,hhmmss.ss,a,a,a,aaa,x.x,x.x,x.x,x,c--c,\*hh<CR><LF>  
 1 2 3 4 5 6 7 8 9 10 11 12 13

1. Total number of ALF sentences this message (1, 2)
2. Sentence number (1, 2)
3. Sequential message identifier (0 - 9)
4. Time of last change (000000.00 - 240001.00 / null)  
 null when #2 is 2
5. Alert category (A/ B/null)  
 A=Alert category A, B=Alert category B, null when #2 is 2
6. Alert priority (A/W/C/null)  
 A=Alarm, W=Warning, C=Caution, null when #2 is 2
7. Alert state (A/S/O/U/V/N/null)  
 A=Acknowledged  
 S=Silence  
 O=Active-responsibility transferred  
 U=Rectified-unacknowledged  
 V=Not acknowledged  
 N=Normal state  
 null when #2 is 2
8. Manufacturer mnemonic code (FEC/null)
9. Alert identifier (1 - 999 or 10001 - 10999)
10. Alert instance (null)
11. Revision counter (1 - 99)
12. Escalation counter (0 - 9)
13. Alert text (max. 16 characters)

**ALR - Set alarm state**

\$\*\*ALR,hhmmss.ss,xxx,A,A,c—c,\*hh<CR><LF>  
                   1   2  3  4  5

1. Time of alarm condition change, UTC (000000.00 - 240001.00)
2. Unique alarm number (identifier) at alarm source (001 - 999 / null)
3. Alarm condition (A/V)  
     A=threshold exceeded  V=not exceeded
4. Alarm acknowledge state (A/V)  
     A=acknowledged  V=not acknowledged
5. Alarm description text (alphanumeric characters, max. 32)

**ARC - Alert command refused**

\$\*\*ARC,hhmmss.ss,aaa,x.x,x.x,c\*hh<CR><LF>  
                   1          2   3  4  5

1. Release time of the alert command refused (000000.00 - 240001.00, null)
2. Used for proprietary alerts, defined by the manufacturer (FEC)
3. The alert identifier (10001 - 10999)
4. The alert instance (null)
5. Refused alert command (A/O)  
     A=acknowledge,  O=responsibility transfer

**BBM - UAIS broadcast binary message**

!\*\*BBM,x,x,x,x,xx,s--s,x,\*hh<CR><LF>  
           1  2  3  4  5   6  7

1. Total number of sentences needed to transfer the message (1 - 9)
2. Sentence number (1 - 9)
3. Sequential message identifier (0 - 9)
4. AIS channel for broadcast of the radio message (0 - 3/null)
5. VDL message number (8/14/null)
6. Encapsulated data (1 - 63 bytes)
7. Number of fill-bits (0 - 5)

**EVE - General event message**

\$\*\*EVE,hhmmss.ss,c--c,c--c\*hh<CR><LF>  
                   1      2   3

1. Event time (000000.00 - 240001.00, null)
2. Tag code used for identification of source of event (six alphanumeric characters, two English characters, four digits)
3. Event description (OPERATION)

**Note:** The EVE sentence is output after input has been detected from either the trackball or the keyboard.

**HBT - Heartbeat supervision sentence**

\$\*\*HBT,x.x,A,x\*hh<CR><LF>  
           1  2  3

1. Configured repeat interval (60.0)
2. Equipment status (A)  
     A=Normal
3. Sequential sequence identifier (0 - 9)

## APPENDIX 2 DIGITAL INTERFACE

### OSD - Own ship data

\$\*\*OSD,x.x,A,x.x,a,x.x,a,x.x,x,x,x,a\*hh<CR><LF>  
1 2 3 4 5 6 7 8 9

1. Heading, degrees true (0.0 - 359.9, null)
2. Heading status (A/V)  
A=data valid V=data invalid
3. Vessel course, degrees true (0.0 - 359.9)
4. Course reference (B/M/W/R/P, null)  
B=Bottom tracking log  
M=Manually entered  
W=Water referenced  
R=Radar tracking (of fixed target)  
P=Positioning system ground reference
5. Vessel speed (0.0 - 99.9)
6. Speed reference (B/M/W/R/P, null)
7. Vessel set, degrees true, manually entered(0.0 - 359.9, null)
8. Vessel drift (speed), manually entered (0.0 – 19.9, null)
9. Speed units (K/N/S, null)  
K=km/h N=Knots S=Statute mile

### RSD - Radar ship data

\$\*\*RSD,x.x,x.x,x.x,x.x,x.x,x.x,x.x,x.x,x.x,x.x,x.x,x.x,aH\*hh <CR><LF>  
1 2 3 4 5 6 7 8 9 10 11 12 13

1. Origin 1 range, from own ship (0.000 - 9999, null) (see note 2)
2. Origin 1 bearing, degrees from 0 (0.0 - 359.9) (see note 2)
3. Variable range marker 1(VRM1), range (0.000 – 999.9, null)
4. Bearing line 1(EBL1), degrees from 0 (0.0 - 359.9, null)
5. Origin 2 range (0.000 - 9999, null) (see note 2)
6. Origin 2 bearing (0.0 - 359.9)(see note 2)
7. VRM2,.9 range (0.000 - 999.9, null)
8. EBL2, degrees (0.0 - 359.9, null)
9. Cursor range, from own ship (0.000 - 999.9)
10. Cursor bearing, degrees clockwise from 0 (0.0 - 359.9)
11. Range scale in use (0.0625 - 120)
12. Range units (K/N/S)  
K=km/h N=Knots S=Statute mile
13. Display rotation (C/H/N, null)(see note 1)

#### NOTES

- 1 Display rotation:  
C=Course-up, course-over-ground up, degrees true  
H=Head-up, ship's heading(center-line) 0 up  
N=North-up, true north is 0 up  
null=Stern-up
- 2 Origin 1 and origin 2 are located at the stated range and bearing from own ship and provide for two independent sets of variable range markers (VRM) and electronic bearing lines (EBL) originating away from own ship position.

### TLB - Target label

\$\*\*TLB,x.x,c--c,x.x,c--c,...,x.x,c--c\*hh<CR><LF>  
1 2 3 3

1. Target number “n” reported by the device (1 - 1023)
2. Label assigned to target “n” (TT=000 - 999, AIS=000000000 - 999999999)
3. Additional label pairs

**TLL - Target latitude and longitude**

```
$**TLL,xx,lll.ll,a,yyyy.yy,a,c--c,hhmmss.ss,a,a*hh<CR><LF>
  1  2 3  4  5 6      7      8 9
```

1. Target number (Fixed at null)
2. Target Latitude (0000.0000 - 9000.0000)
3. Target N/S (N/S)
4. Target Longitude (00000.0000 - 18000.0000)
5. Target E/W (E/W)
6. Target name (Fixed at null)
7. UTC of data (000000.00 - 235959.99)
8. Target status (Fixed at null)
9. Reference target (Fixed at null)

**TTD - Tracked target data**

```
!**TTD,hh,hh,x,s--s,x*hh<CR><LF>
  1  2 3 4 5
```

1. Total hex number of sentences need to transfer the message (1 - FF)
2. Hex sentence number (1 - FF)
3. Sequential message identifier (0 - 9)
4. Encapsulated trancked target data (6 bit binary-converted data)
5. Number of fill bits (0 - 5)

**TTM - Tracked target message**

```
$**TTM,xx,x.x,x.x,a,x.x,x.x,a,x.x,x.x,a,c--c,a,a,hhmmss.ss,a*hh<CR><LF>
  1  2 3 4 5  6 7 8  9 10 11 12 13  14  15
```

1. Target number (00 - 99)
2. Target distance from own ship (0.000 - 99.999)
3. Bearing from own ship,degrees (0.0 - 359.9)
4. True or Relative (T)
5. Target speed (0.00 - 999.99, null)
6. Target course, degrees (0.0 - 359.9, null)
7. True or Relative output (T/R)
8. Distance of closet point of approach (0.00 - 99.99, null)
9. Time to CPA, min., "-" increasing (-99.99 - 99.99, null)
10. Speed/distance units (N)  
N=nm
11. Target name (null)
12. Target status (L/Q/T)  
L=Lost Q=Acquiring T=Tracking
13. Reference target (R/null)
14. UTC of data (null)
15. Type of acquisition (A/M)  
A=Automatic M=Manual

## APPENDIX 2 DIGITAL INTERFACE

### VSD - UAIS Voyage static data

\$--VSD,x.x,x.x,x.x,c--c,hhmmss.ss,xx,xx,x.x,x.x\*hh<CR><LF>  
1 2 3 4 5 6 7 8 9

1. Type of ship and cargo category (null)
  2. Maximum present static draught (0 - 25.5, null)
  3. Persons on-board (0 - 8191, null)
  4. Destination (Alphanumeric character, null)
  5. Estimated UTC of arrival at destination (000000.00 - 246000.00\*, null)
  6. Estimated day of arrival at destination (00 - 31) (UTC)
  7. Estimated month of arrival at destination (00 - 12) (UTC)
  8. Navigational status (0 - 15)
    - 0=Under way using engine
    - 1=At anchor
    - 2=Not under command
    - 3=Restricted maneuverability
    - 4=Constrained by her draught
    - 5=Moored
    - 6=Aground
    - 7=Engaged in Fishing
    - 8=Under way sailing
    - 9=HSC
    - 10=WIG
    - 11=Power-driven vessel towing astern
    - 12=Power-driven vessel pushing ahead or towing alongside
    - 13=Reserved for future use
    - 14=AIS-SART (active), MOB-AIS, EPIRB-AIS
    - 15=Undefined = default (also used by AIS-SART, MOB-AIS and EPIRB AIS under test)
  9. Regional application flags (null)
- \* 246000.00 when ETA is not set.

Serial Interface

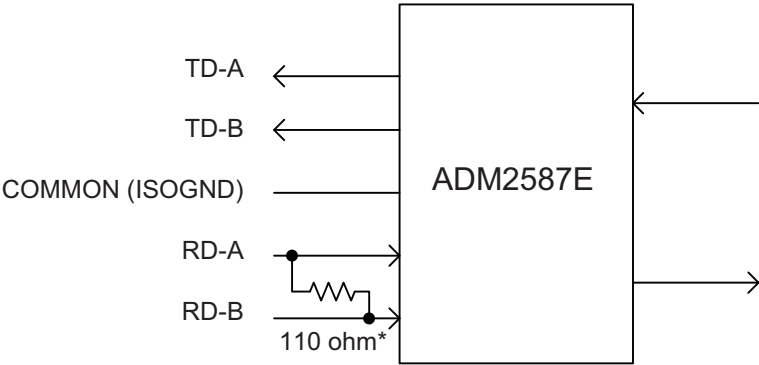

\* Set with jumper.  
Open/close switchable.

IEC 61162-2 input/output

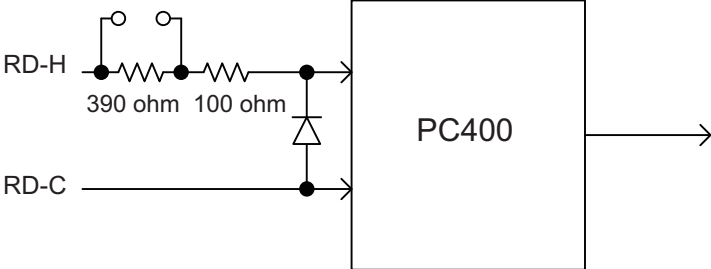

IEC 61162-1 input

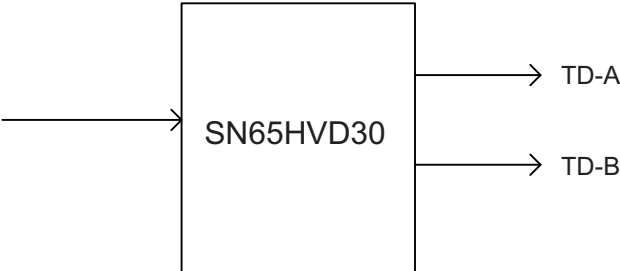





IEC 61162-1 output

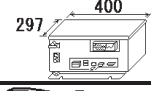
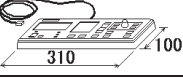

# PACKING LIST

RC28RP24-\*J60\*/HK , RC28RP24-\*E60\*/HK , RC28RP24-\*E72\*/HK  
(AG)

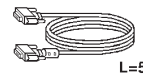
03HQ-X-9858-1 1/1

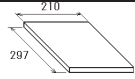
A-2

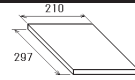
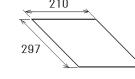
NAME	OUTLINE	DESCRIPTION/CODE No.	Q' TY
<b>ユニット UNIT</b>			
制御部 PROCESSOR UNIT		RPU024-* 000-028-065-00 **	1
操作部 CONTROL UNIT		RCU-028* 000-027-860-00 **	1
<b>予備品 SPARE PARTS</b>			
予備品 SPARE PARTS		SP03-18002 001-419-830-00	1
<b>工事材料 INSTALLATION MATERIALS</b>			
ケーブル組品 CABLE ASSEMBLY		DVI-D/D S-LINK 5M 001-132-960-10	1
工事材料 INSTALLATION MATERIALS		CP03-36501 001-419-860-00	1
工事材料 INSTALLATION MATERIALS		CP03-36601 001-419-600-00	1
<b>図書 DOCUMENT</b>			
取扱説明書(英) OPERATOR'S MANUAL (EN)		OME-36380-* 000-190-831-1* (*2)	1

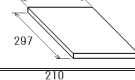
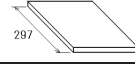
NAME	OUTLINE	DESCRIPTION/CODE No.	Q' TY
取扱説明書(和) OPERATOR'S MANUAL (JP)		OMJ-36420-* 000-192-103-1* (*1)	1
操作要領書(多言語) OPERATOR'S GUIDE (MLG)		MLG-36380-* 000-190-833-1* (*2)	1
操作要領書(和) OPERATOR'S GUIDE (JP)		OSJ-36420-* 000-192-105-1* (*1)	1
装備要領書(英) INSTALLATION MANUAL (EN)		IME-36380-* 000-190-835-1* (*2)	1
装備要領書(和) INSTALLATION MANUAL (JP)		IMJ-36420-* 000-192-104-1* (*1)	1

1.コード番号末尾の[\*\*]は、選択品の代表コードを表します。  
CODE NUMBER ENDING WITH "\*\*" INDICATES THE CODE NUMBER OF REPRESENTATIVE MATERIAL.

2.(\*1)の書類は、和文仕様専用です。  
(\*1) MARKED DOCUMENTS ARE FOR JAPANESE SET ONLY.

(略図の寸法は、参考値です。DIMENSIONS IN DRAWING FOR REFERENCE ONLY.)

3.(\*2)の書類は、和文仕様専用です。  
(\*2) MARKED DOCUMENTS ARE FOR ENGLISH SET ONLY.





C3638-Z05-B

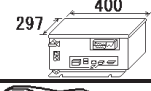
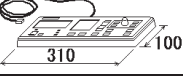

# PACKING LIST

RC28RP24-\*J2\*/HK , RC28RP24-\*E2\*/HK (DC)

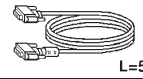
03HQ-X-9857-1 1/1

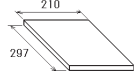
A-1

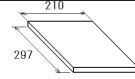
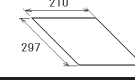
NAME	OUTLINE	DESCRIPTION/CODE No.	Q' TY
<b>ユニット UNIT</b>			
制御部 PROCESSOR UNIT		RPU024-* 000-028-065-00 **	1
操作部 CONTROL UNIT		RCU-028* 000-027-860-00 **	1
<b>予備品 SPARE PARTS</b>			
予備品 SPARE PARTS		SP03-18001 001-419-820-00	1
<b>工事材料 INSTALLATION MATERIALS</b>			
ケーブル組品 CABLE ASSEMBLY		DVI-D/D S-LINK 5M 001-132-960-10	1
工事材料 INSTALLATION MATERIALS		CP03-36501 001-419-860-00	1
工事材料 INSTALLATION MATERIALS		CP03-36601 001-419-600-00	1
<b>図書 DOCUMENT</b>			
取扱説明書(英) OPERATOR'S MANUAL (EN)		OME-36380-* 000-190-831-1* (*2)	1

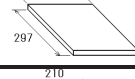
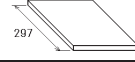
NAME	OUTLINE	DESCRIPTION/CODE No.	Q' TY
取扱説明書(和) OPERATOR'S MANUAL (JP)		OMJ-36420-* 000-192-103-1* (*1)	1
操作要領書(多言語) OPERATOR'S GUIDE (MLG)		MLG-36380-* 000-190-833-1* (*2)	1
操作要領書(和) OPERATOR'S GUIDE (JP)		OSJ-36420-* 000-192-105-1* (*1)	1
装備要領書(英) INSTALLATION MANUAL (EN)		IME-36380-* 000-190-835-1* (*2)	1
装備要領書(和) INSTALLATION MANUAL (JP)		IMJ-36420-* 000-192-104-1* (*1)	1

1.コード番号末尾の[\*\*]は、選択品の代表コードを表します。  
CODE NUMBER ENDING WITH "\*\*" INDICATES THE CODE NUMBER OF REPRESENTATIVE MATERIAL.

2.(\*1)の書類は、和文仕様専用です。  
(\*1) MARKED DOCUMENTS ARE FOR JAPANESE SET ONLY.



(略図の寸法は、参考値です。DIMENSIONS IN DRAWING FOR REFERENCE ONLY.)

3.(\*1)の書類は、英文仕様専用です。  
(\*1) MARKED DOCUMENTS ARE FOR ENGLISH SET ONLY.

C3638-Z04-B

# PACKING LIST

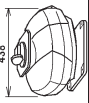
RSB-0070-085A, RSB-0070-086A, RSB-0070-087A, RSB-0073-085A, RSB-0073-086A, RSB-0073-087A  
 036T-X-9854 -1 1/1 A-3

NAME	OUTLINE	DESCRIPTION/CODE No.	Q'TY
<b>ユニット UNIT</b>			
空中線本体部 SCANNER UNIT		RSB-0070-08*A/-0073-08*A 001-125-220-00 **	1
<b>空中線部工材 ANTENNA UNIT INSTALLATION MATERIALS</b>			
空中線部工材 INSTALLATION MATERIALS		CP03-33801 001-141-670-00	1



コード番号末尾の[\*\*]は、選択品の代表コードを表します。  
 CODE NUMBER ENDING WITH "\*\*" INDICATES THE CODE NUMBER OF REPRESENTATIVE MATERIAL.

型式/コード番号が2版の場合、下版より上段に代わる過渡期品であり、どちらが入っています。なお、品質は変わりません。  
 TWO TYPES AND CODES MAY BE LISTED FOR AN ITEM. THE LOWER PRODUCT MAY BE SHIPPED IN PLACE OF THE UPPER PRODUCT. QUALITY IS THE SAME.  
 (略図の寸法は、参考値です。 DIMENSIONS IN DRAWING FOR REFERENCE ONLY.)

C3539-Z04-B

# PACKING LIST

RSB-120-1M0, RSB-121-1M0, RSB-120-1HK, RSB-121-1HK  
 03HC-X-9851 -0 1/1 A-4





NAME	OUTLINE	DESCRIPTION/CODE No.	Q'TY
<b>ユニット UNIT</b>			
空中線本体部 SCANNER UNIT		RSB-120-*/121-* 000-027-849-00 **	1
<b>予備品 SPARE PARTS</b>			
空中線予備品 SPARE PARTS		SP03-12501 008-489-360-00	1
<b>工事材料 INSTALLATION MATERIALS</b>			
工事材料 INSTALLATION MATERIALS		CP03-33402 001-419-290-00	1

コード番号末尾の[\*\*]は、選択品の代表コードを表します。  
 CODE NUMBER ENDING WITH "\*\*" INDICATES THE CODE NUMBER OF REPRESENTATIVE MATERIAL.

(略図の寸法は、参考値です。 DIMENSIONS IN DRAWING FOR REFERENCE ONLY.)

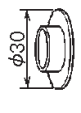
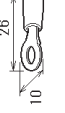
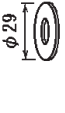
C3642-Z01-A

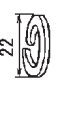
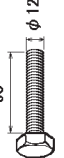
CODE NO.	001-419-290-00	03HQ-X-9401-0
TYPE	CP03-33402	1/2

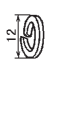
工事材料表		INSTALLATION MATERIALS		数量		用途/備考	
番号	名称	略図	型名/規格	数量	用途/備考	数量	用途/備考
NO.	NAME	OUTLINE	DESCRIPTIONS	QTY	REMARKS	QTY	REMARKS
1	防蝕ゴム、1. CORROSION-PROOF RUBBER		03-001-3001-0 ROHS CODE NO. 300-130-010-10	1			
2	シーリングワッシャー SEAL WASHER		03-001-3002-0 ROHS CODE NO. 300-130-020-10	4			
3	圧着端子 CRIMP-ON LUG		FV6.5-4(LF) TEL CODE NO. 000-166-744-10	1			
4	ケーブル用盛金 CABLE GLAND WASHER		JIS F8801 Z6C CODE NO. 000-171-883-10	3			
5	六角ナット 1½ HEXAGONAL NUT		M12 SUS304 CODE NO. 000-167-491-10	4			
6	ミカキワ平盛金 FLAT WASHER		M12 SUS304 CODE NO. 000-167-446-10	4			
7	ハネ盛金 SPRING WASHER		M12 SUS304 CODE NO. 000-167-397-10	4			
8	六角ナット 全ネジ HEXAGON HEAD SCREW		M12x60 SUS304 CODE NO. 000-162-813-10	4			
9	六角ナット 1½ HEXAGONAL NUT		M6 SUS304 CODE NO. 000-158-856-10	1			
10	ハネ盛金 SPRING WASHER		M6 SUS304 CODE NO. 000-158-855-10	1			

(略図の寸法は、参考値です。 DIMENSIONS IN DRAWING FOR REFERENCE ONLY.)

FURUNO ELECTRIC CO., LTD.

CODE NO.	001-419-290-00	03HQ-X-9401-0
TYPE	CP03-33402	2/2

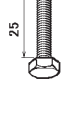
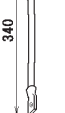

工事材料表		INSTALLATION MATERIALS		数量		用途/備考	
番号	名称	略図	型名/規格	数量	用途/備考	数量	用途/備考
NO.	NAME	OUTLINE	DESCRIPTIONS	QTY	REMARKS	QTY	REMARKS
11	ミカキワ平盛金 FLAT WASHER		M6 SUS304 CODE NO. 000-158-854-10	3			
12	六角ナット HEXAGONAL HEAD BOLT		M6x25 SUS304 CODE NO. 000-162-871-10	1			
13	ケーブル組品 CABLE ASSY.		RW-4747 CODE NO. 000-566-000-12	1			

(略図の寸法は、参考値です。 DIMENSIONS IN DRAWING FOR REFERENCE ONLY.)

FURUNO ELECTRIC CO., LTD.

CODE NO.	001-419-860-00	03HQ-X-9402-2
TYPE	CP03-36501	1/1

**工事材料表**

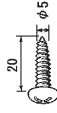
INSTALLATION MATERIALS		略 図 OUTLINE	型名/規格 DESCRIPTIONS	数 量 Q T Y	用 途 / 備 考 REMARKS
番 号 NO.	名 称 NAME				
1	7' ブラインドシ-アンズ BLIND SEAL N2.5		05-104-6919-0 CODE NO. 100-372-550-10	1	
2	イソワックス-7A INSULATION TUBE		3.0X0.3 TEL *500mm CODE NO. 000-162-641-10	8	
3	+トネリビス SELF-TAPPING SCREW		5X20 SUS304 CODE NO. 000-162-608-10	4	

(略図の寸法は、参考値です。 DIMENSIONS IN DRAWING FOR REFERENCE ONLY.)

FURUNO ELECTRIC CO., LTD.

CODE NO.	001-419-600-00	03HQ-X-9403-0
TYPE	CP03-36601	1/1

**工事材料表**

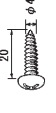
INSTALLATION MATERIALS		略 図 OUTLINE	型名/規格 DESCRIPTIONS	数 量 Q T Y	用 途 / 備 考 REMARKS
番 号 NO.	名 称 NAME				
1	+トネリビス SELF-TAPPING SCREW		4X20 SUS304 CODE NO. 000-162-650-10	4	

(略図の寸法は、参考値です。 DIMENSIONS IN DRAWING FOR REFERENCE ONLY.)

FURUNO ELECTRIC CO., LTD.





表 2 TABLE 2

種類 (TYPE)	XN10A	XN12A	XN13A
空中線長 (A) ANT. LENGTH (mm)	1036±10	1255±10	1795±10
回転安全空間 (B) ANT. CLEARANCE (mm)	1200	1400	1940
質量 (kg±10%) MASS	22	25	27

表 1 TABLE 1

寸法区分 (mm) DIMENSION	公差 (mm) TOLERANCE
L ≤ 50	±1.5
50 < L ≤ 100	±2.5
100 < L ≤ 500	±3
500 < L ≤ 1000	±4
1000 < L ≤ 2000	±5

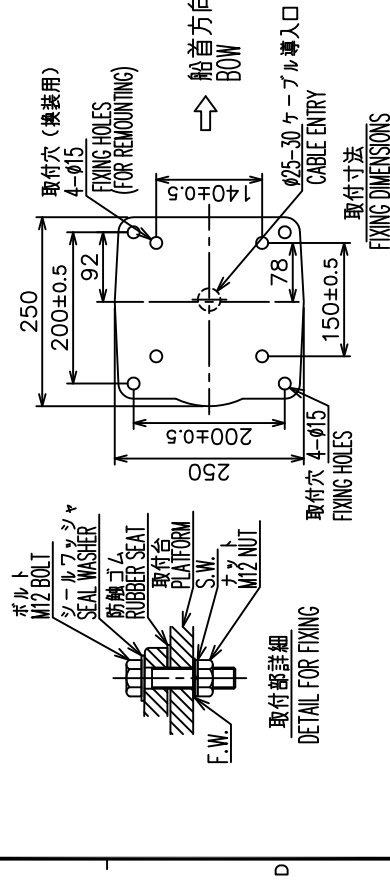
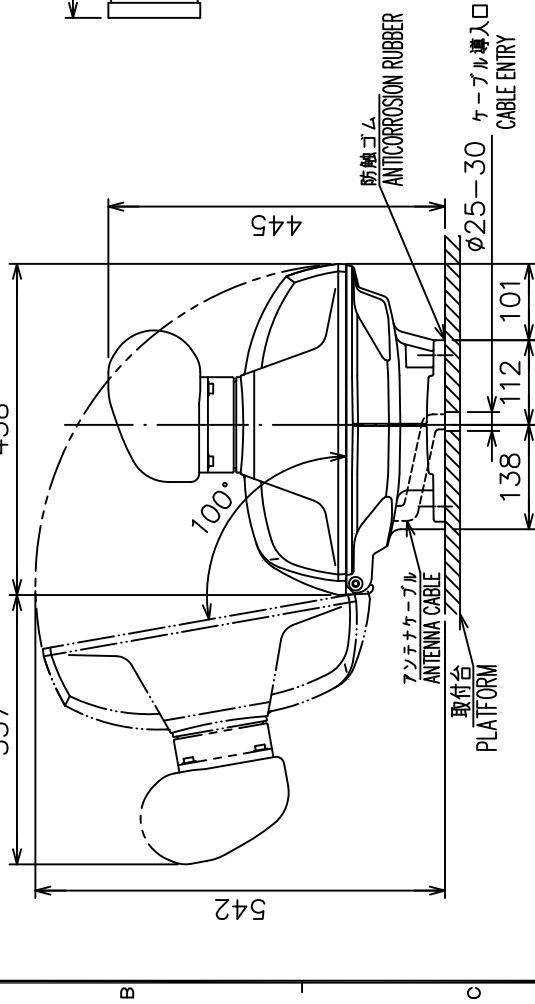
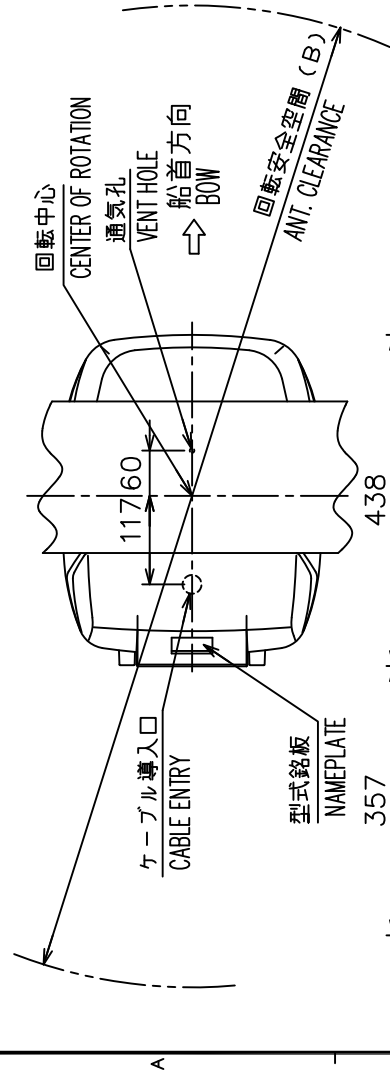
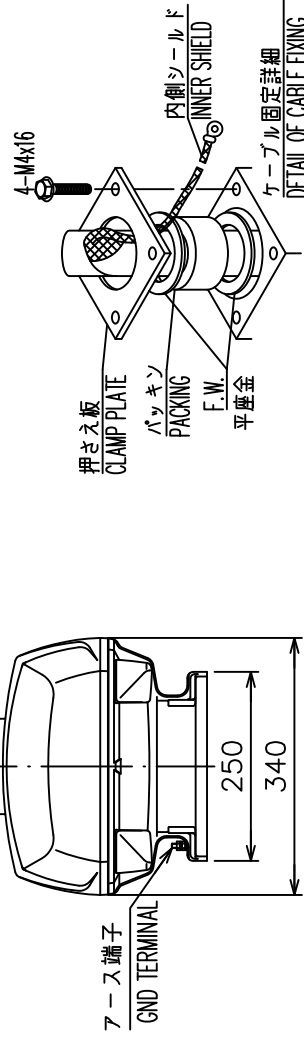

- 注記
- 1) 指定なき寸法公差は表 1 による。
  - 2) 取付には M12 ボルトを使用のこと。
  - 3) 通気孔は塞がないこと。

NOTE

1. TABLE 1 INDICATES TOLERANCE OF DIMENSIONS WHICH IS NOT SPECIFIED.
2. USE M12 BOLTS FOR FIXING THE UNIT.
3. DO NOT COVER THE VENT HOLE.

DRAWN	18/Sep/2015	I. YAMASAKI	TITLE	RSB-0070/0072/0073
CHECKED	18/Sep/2015	H. MAKI	名称	空中線部
APPROVED	18/Sep/2015	H. MAKI	OTHERS	MODEL1642/E, MODEL1654/C, ser.
SCALE	1/10	質量 差之参照	FR-706Z/806Z, ser.	外寸図
DWG.No.	C3539-G03-D	REF.No.	03-142-300G-6	ANTENNA UNIT
				OUTLINE DRAWING

表1 TABLE 1

寸法区分 (mm) DIMENSION	公差 (mm) TOLERANCE
L ≤ 50	±1.5
50 < L ≤ 100	±2.5
100 < L ≤ 500	±3
500 < L ≤ 1000	±4
1000 < L ≤ 2000	±5

表2 TABLE 2

アンテナ型式 ANTENNA TYPE	XN12AF (120cm型)
A: 空中線長 ANTENNA LENGTH (mm)	1,260 ± 10
B: 回転安全空間 ANTENNA CLEARANCE (mm)	1,400

1 2 3 4 5

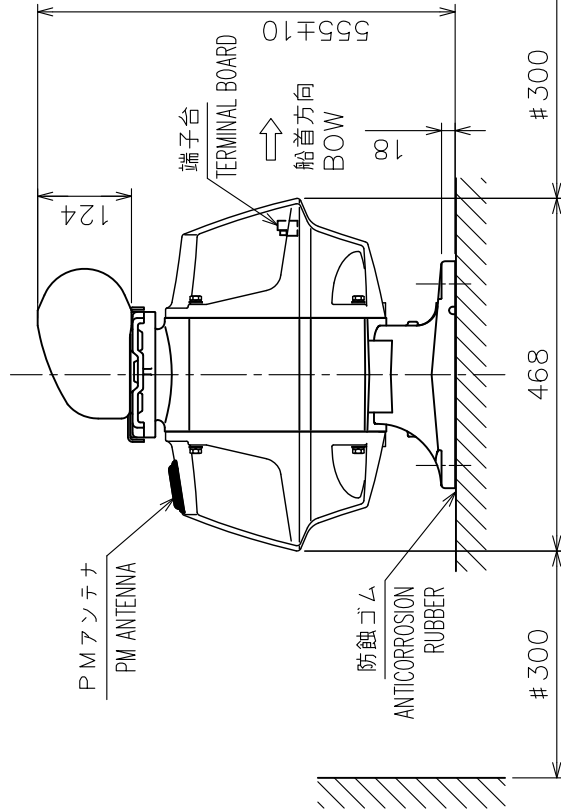
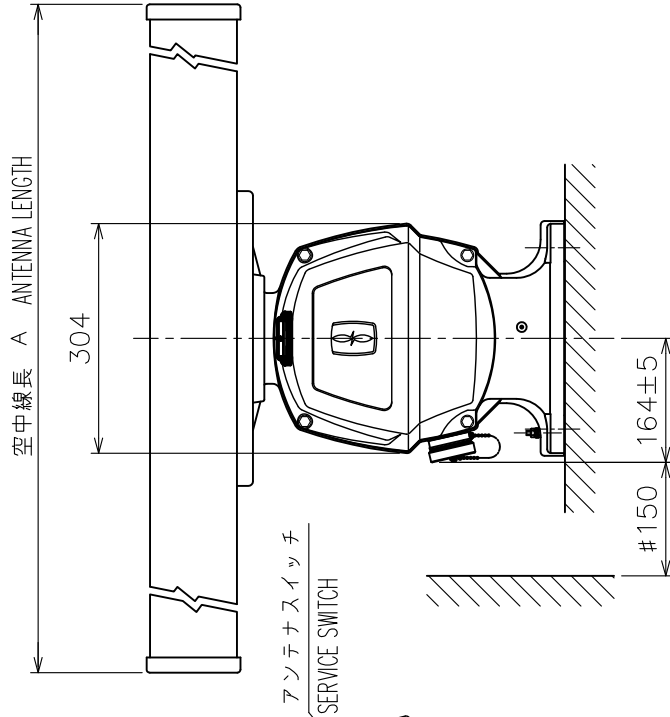
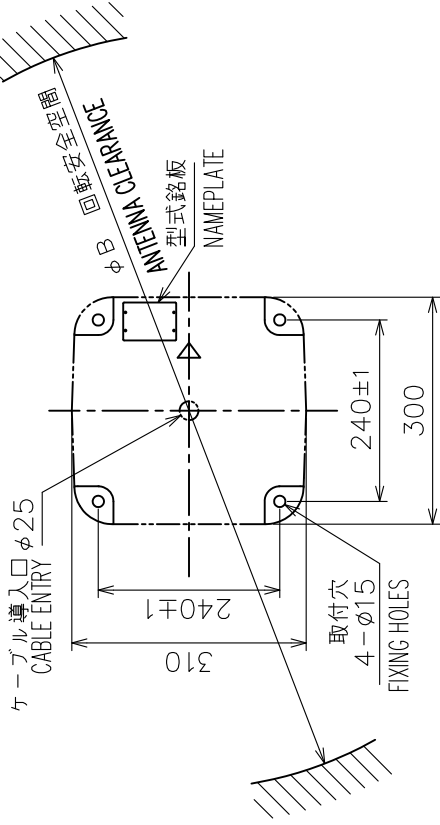

- 注記 1) 指定外の寸法公差は表1による。  
 2) #印寸法は最小サービスマウントを使用すること。  
 3) 取付用ネジはM12ボルトを使用すること。

- NOTE 1. TABLE 1 INDICATES TOLERANCE OF DIMENSIONS WHICH IS NOT SPECIFIED.  
 2. #: MINIMUM SERVICE CLEARANCE.  
 3. USE M12 BOLTS FOR FIXING THE UNIT.

DRAWN	4/Feb/2015 I.YAMASAKI	TITLE	RSB-120/121 (XN12AF)
CHECKED	4/Feb/2015 H.MAKI	名称	空中線部
APPROVED	5/Feb/2015 H.MAKI	外寸図	
SCALE	1/10 MASS 33 #104 kg	NAME	ANTENNA UNIT
DWG.No.	C3642-G01-A	REF.No.	03-186-300G-0

D-2

4

3

2

1

D

C

B

A

表1 TABLE 1

寸法区分 (mm) DIMENSION	公差 (mm) TOLERANCE
L ≤ 50	±1.5
50 < L ≤ 100	±2.5
100 < L ≤ 500	±3
500 < L ≤ 1000	±4
1000 < L ≤ 2000	±5

表2 TABLE 2

アンテナ型式 ANTENNA TYPE	XN20AF (200cm型)	XN24AF (240cm型)
A: 空中線長 ANTENNA LENGTH (mm)	2,040±10	2,550±10
B: 回航安全空間 ANTENNA CLEARANCE (mm)	2,200	2,700
質量 MASS (kg±10%)	39	41

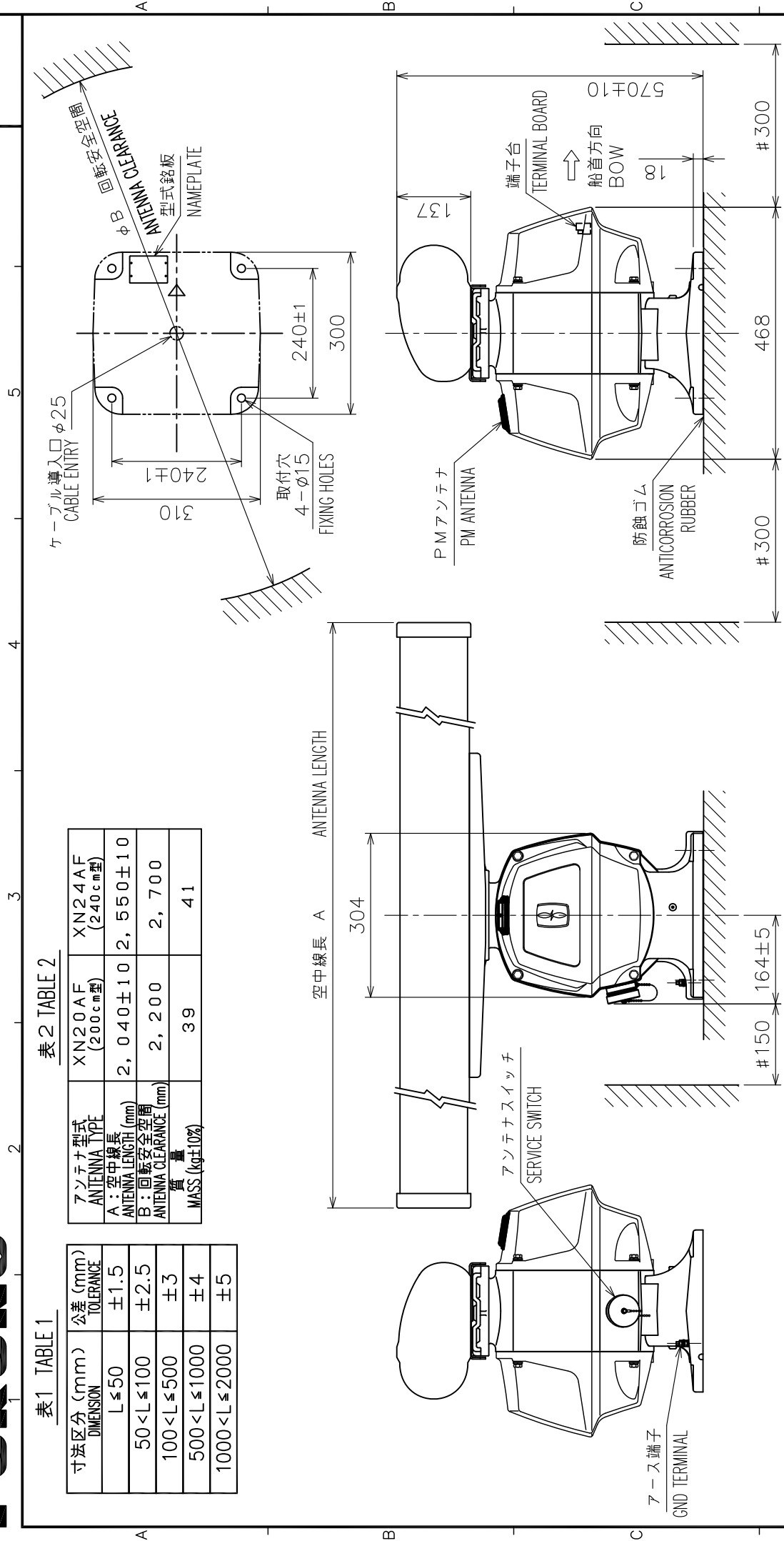

- 注記 1) 指定外の寸法公差は表1による。  
 2) #印寸法は最小サービス空間寸法とする。  
 3) 取付用ネジはM12ボルトを使用のこと。

- NOTE 1. TABLE 1 INDICATES TOLERANCE OF DIMENSIONS WHICH IS NOT SPECIFIED.  
 2. # MINIMUM SERVICE CLEARANCE.  
 3. USE M12 BOLTS FOR FIXING THE UNIT.

DRAWN	4/Feb/2015 I.YAMASAKI	TITLE	RSB-120/121 (XN20AF/24AF)
CHECKED	4/Feb/2015 H.MAKI	名称	空中線部
APPROVED	5/Feb/2015 H.MAKI	外寸図	
SCALE	1/10 MASS表之参照 SEE TABLE 2	NAME	ANTENNA UNIT
DWG.No.	C3642-602-A	REF.No.	03-186-301C-0

OUTLINE DRAWING

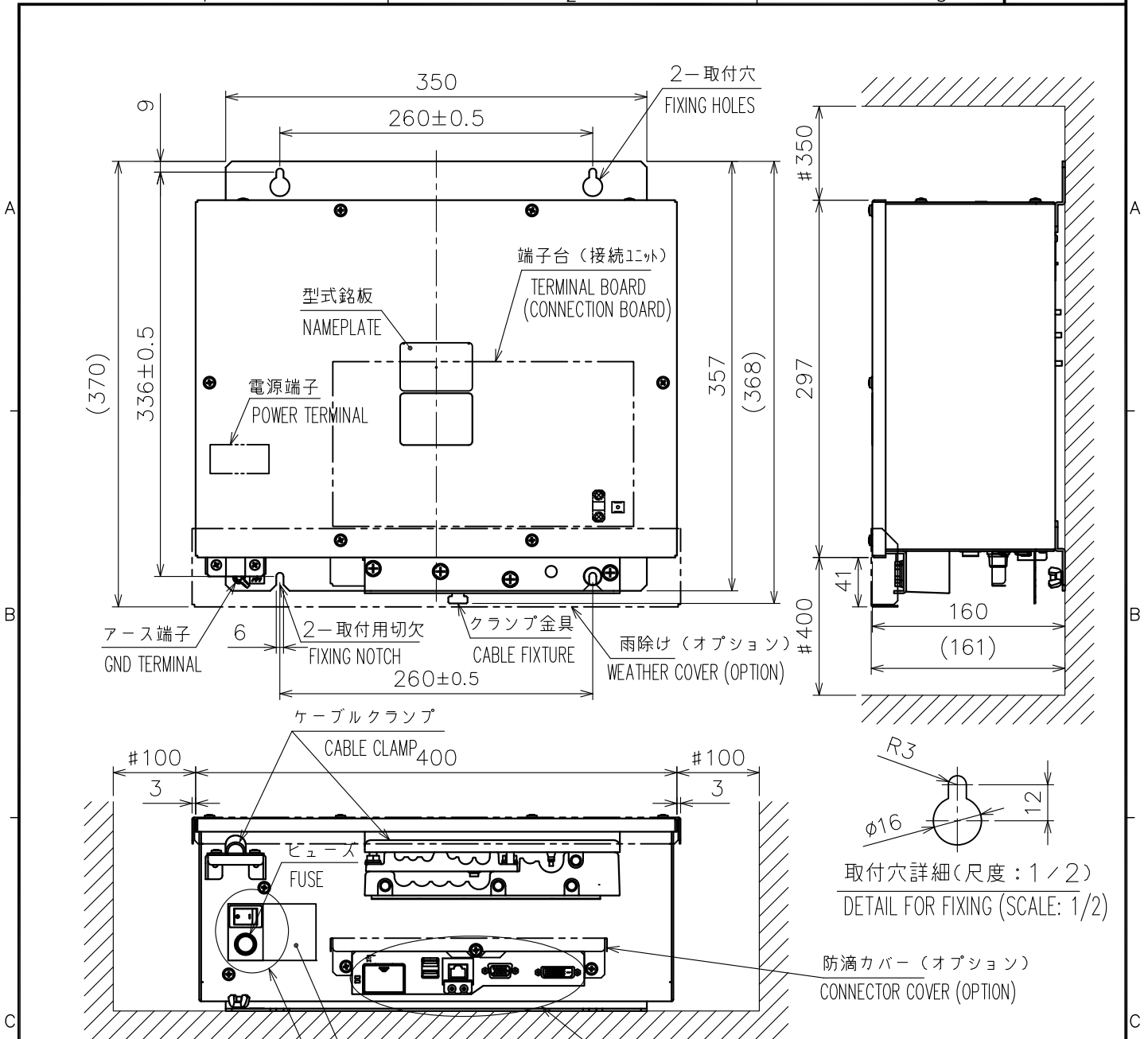

ヒューズ貼りマーク (DC) FUSE LABEL (DC) &部 DC仕様 &: FOR DC SPEC

ヒューズ貼りマーク (AC) FUSE LABEL (AC) &部 (AC仕様) &: FOR AC SPEC

信号コネクタ SIGNAL CONNECTOR

**注記**

- 1) 指定外の寸法公差は表1による。
- 2) #印寸法は最小サービス空間寸法とする。
- 3) 取付用ネジはM5ボルトまたはトラスタップピンネジ呼径5×20を使用のこと。

**NOTE**

1. TABLE 1 INDICATES TOLERANCE OF DIMENSIONS WHICH IS NOT SPECIFIED.
2. #: MINIMUM SERVICE CLEARANCE.
3. USE M5 BOLTS OR TAPPING SCREWS  $\phi 5 \times 20$  FOR FIXING THE UNIT.

表2 TABLE 2

電源 SOURCE	質量 (kg±10%) MASS
DC	6.2
AC	6.8

表1 TABLE 1

寸法区分 (mm) DIMENSION	公差 (mm) TOLERANCE
$L \leq 50$	±1.5
$50 < L \leq 100$	±2.5
$100 < L \leq 500$	±3

DRAWN 3/Feb/2015 T.YAMASAKI	TITLE RPU-024
CHECKED 3/Feb/2015 H.MAKI	名称 制御部
APPROVED 4/Feb/2015 H.MAKI	外寸図
SCALE 1/5	NAME PROCESSOR UNIT
DWG. No. C3638-G01-A	REF. No. 03-186-100G-2
OUTLINE DRAWING	

表 1 TABLE 1

寸法区分 (mm) DIMENSION	公差 (mm) TOLERANCE
L ≤ 50	±1.5
50 < L ≤ 100	±2.5
100 < L ≤ 500	±3

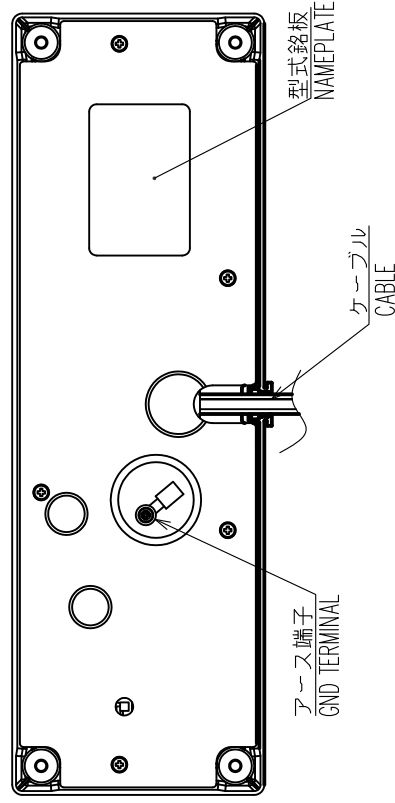
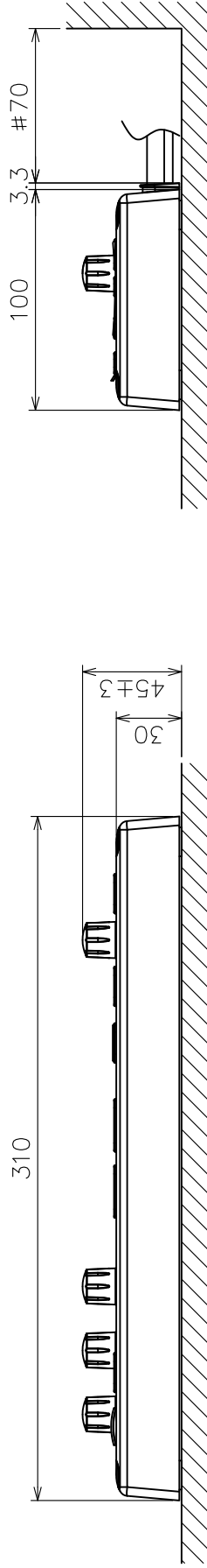
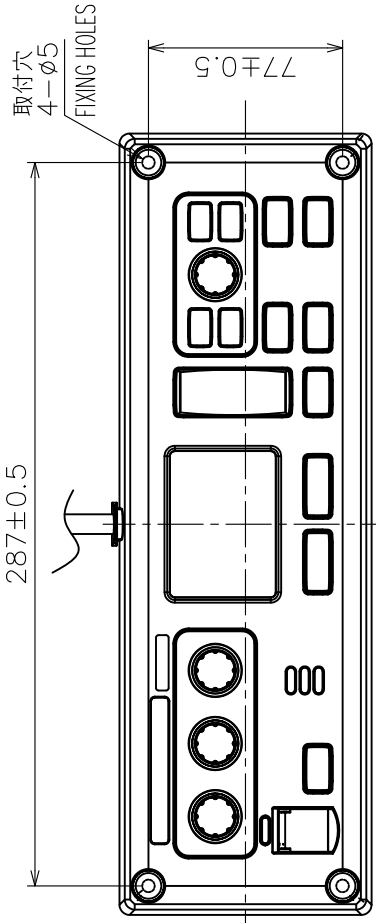

- 注 記
- 1) 指定外の寸法公差は表 1 による。
  - 2) 井印寸法は最少サービス空間寸法とする。
  - 3) 取付ネジはトラスタピンネジ呼び径 4×2.0 を使用のこと。
- NOTE
1. TABLE 1 INDICATES TOLERANCE OF DIMENSIONS WHICH IS NOT SPECIFIED.
  2. #. MINIMUM SERVICE CLEARANCE.
  3. USE TAPPING SCREWS φ4x2.0 FOR FIXING THE UNIT.

DRAWN	19/Jun/2015	T.YAMASAKI	TITLE	RCU-028
CHECKED	19/Jun/2015	H.MAKI	名称	操作部
APPROVED	4/Feb/2015	H.MAKI	外寸図	
SCALE	1/3	質量はケーブル(5m)を含む。 #. MASS INCLUDES 5m CABLE.	NAME	CONTROL UNIT
DWG.No.	C3638-G02-B	REF.No.	03-186-200G-3	OUTLINE DRAWING

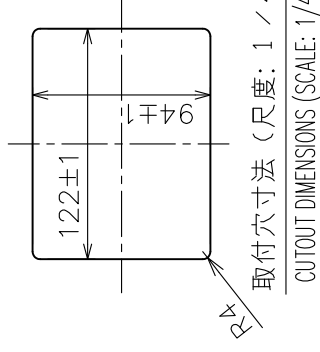
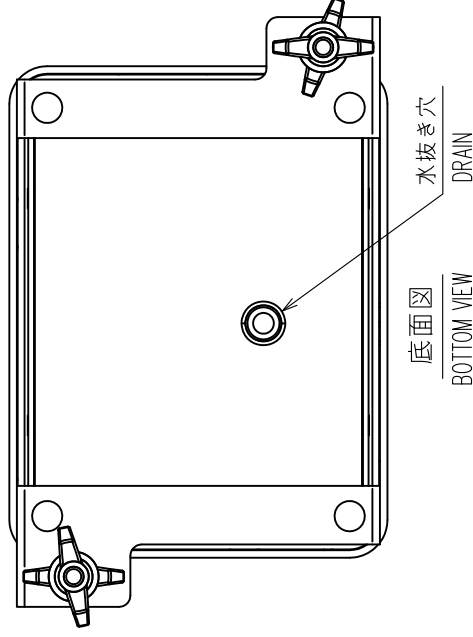
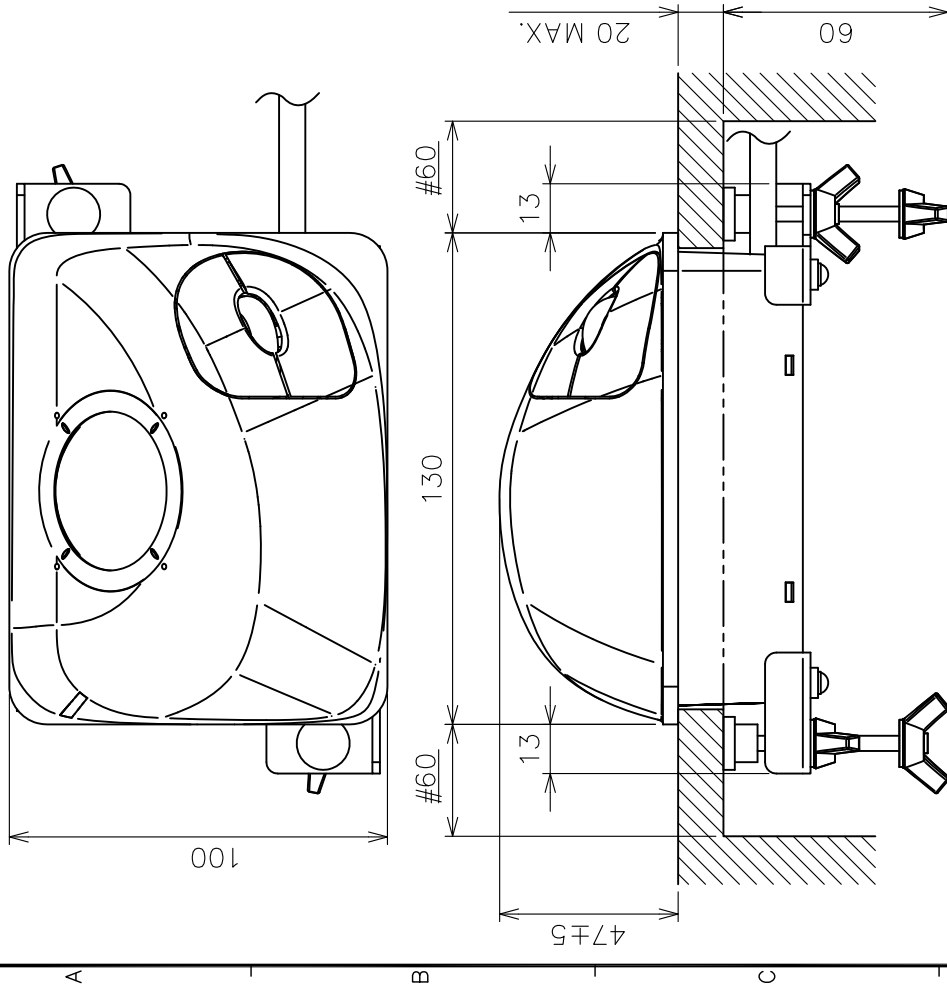

取付寸法 (尺度: 1/4)  
CUTOUT DIMENSIONS (SCALE: 1/4)

表1 TABLE 1

寸法区分 (mm) DIMENSION	公差 (mm) TOLERANCE
L ≤ 50	±1.5
50 < L ≤ 100	±2.5
100 < L ≤ 500	±3

- 注記 1) 指定外の寸法公差は表1による。  
2) #印寸法は最小サービス空間寸法とする。
- NOTE 1. TABLE 1 INDICATES TOLERANCE OF DIMENSIONS WHICH IS NOT SPECIFIED.  
2. # MINIMUM SERVICE CLEARANCE.

DRAWN	6/Nov/2013	T. YAMASAKI	TITLE	RCU-030
CHECKED	6/Nov/2013	H. MAKI	名称	トラックボール操作部 (埋込装備)
APPROVED	7/Nov/2013	H. MAKI	外寸図	
SCALE	1/2	質量 0.5 kg #104質量はケーブルを含む。 #104 MASS INCLUDES 2m. CABLE.	NAME	TRACKBALL CONTROL UNIT (FLUSH MOUNT)
DWG.No.	C4484-G02-A	REF.No.	24-016-120G-0	OUTLINE DRAWING

1 2 3 4 5



表1 TABLE 1

寸法区分 (mm) DIMENSION	公差 (mm) TOLERANCE
L ≤ 50	±1.5
50 < L ≤ 100	±2.5
100 < L ≤ 500	±3

- 注 記
- 1) 指定外の寸法公差は表1による。
  - 2) #印寸法は最小サービスマウントとする。
  - 3) 取付ネジはトラスタックピピンネジ呼び径5×20を使用のこと。
- NOTE
1. TABLE 1 INDICATES TOLERANCE OF DIMENSIONS WHICH IS NOT SPECIFIED.
  2. #: MINIMUM SERVICE CLEARANCE.
  3. USE TAPPING SCREWS φ5x20 FOR FIXING THE UNIT.

DRAWN	6/Nov/2013	T. YAMASAKI	TITLE	RCU-030
CHECKED	6/Nov/2013	H. MAKI	名称	トラックボール操作部 (取付金具)
APPROVED	7/Nov/2013	H. MAKI	外寸図	
SCALE	1/2	質量 0.4 kg	NAME	TRACKBALL CONTROL UNIT (FIXTURE MOUNT)
DWG.No.	C4484-G01-A	質量は2mケーブルを含む。 REF.No. 24-016-110G-0	OUTLINE DRAWING	

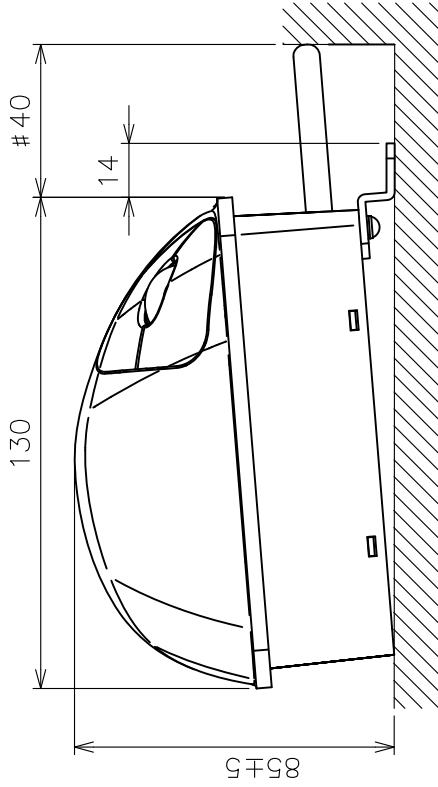
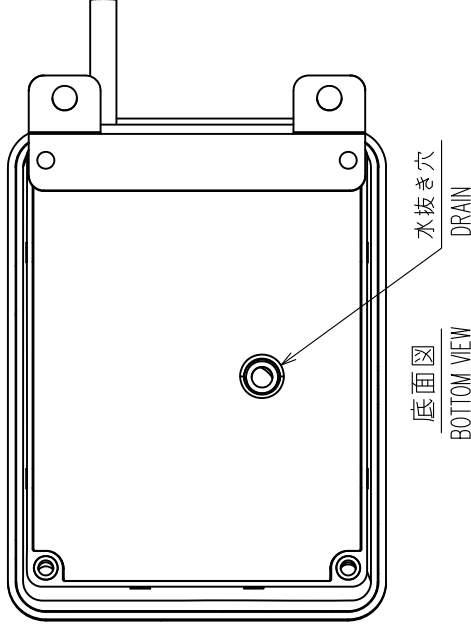
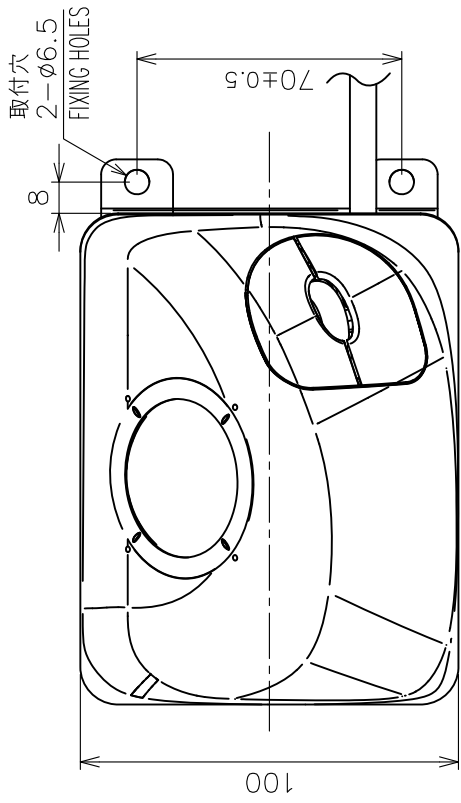
RSB-0070: 24rpm  
RSB-0073: 48rpm

4

3

2

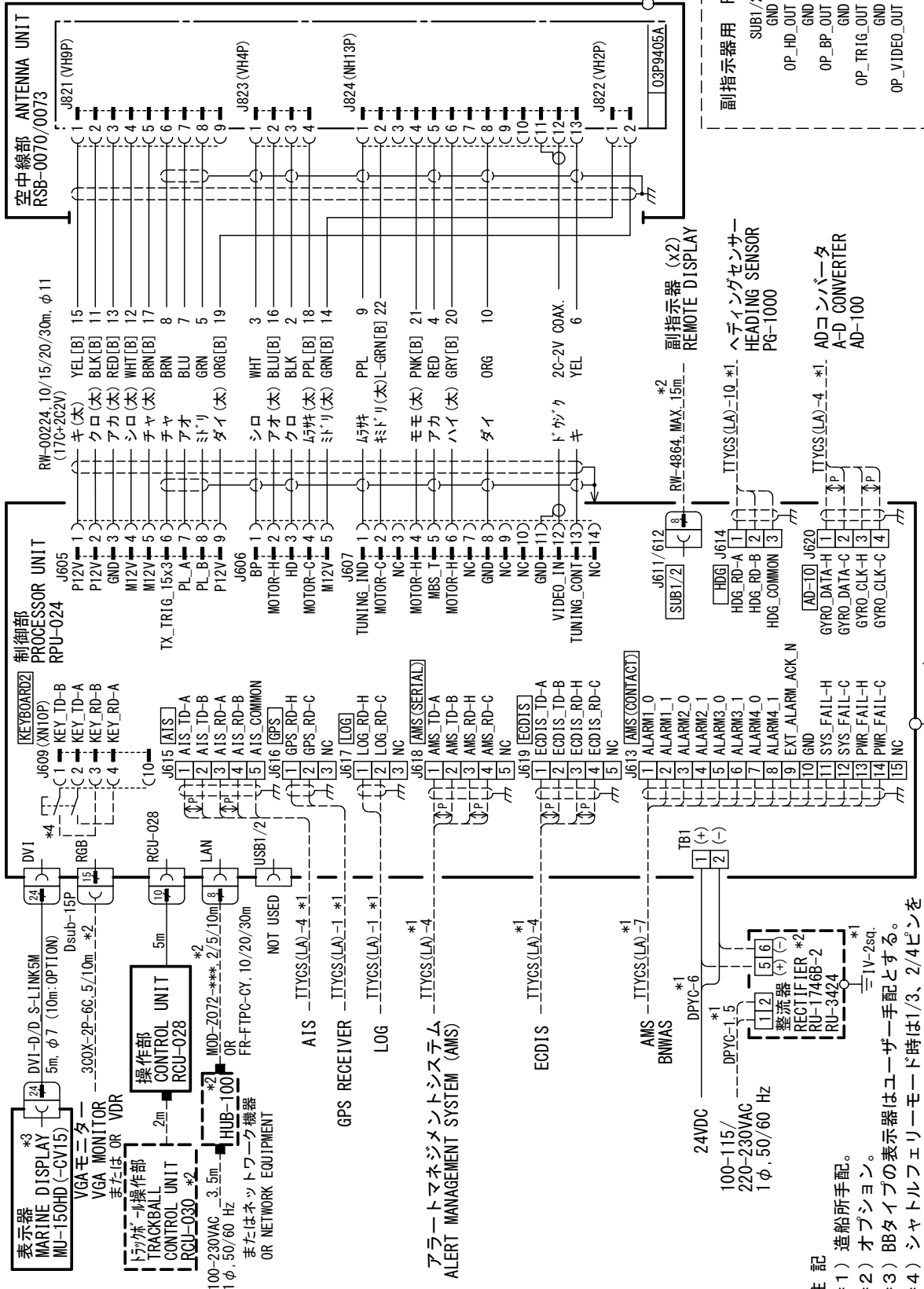

DRAWN	29/Sep/2016	T. YAMASAKI	TYPE	FAR-1513 (-BB)
CHECKED	30/Sep/2016	H. MAKI	名称	船舶用レーダー
APPROVED	30/Sep/2016	H. MAKI		相互結線図
SCALE	MASS	kg	NAME	MARINE RADAR
DWG. No.	C3638-001-E		REF. No.	03-186-6001-0
				INTERCONNECTION DIAGRAM

**注記**

- \*1) 造船所手配。
- \*2) オプション。
- \*3) BBタイプの表示器はユーザー手配とする。
- \*4) シャトルフェリーモード時は1/3、2/4ピンを外部スイッチ (ユーザー手配) でジャンパーする。

**NOTE**

- \*1: SHIPYARD SUPPLY.
- \*2: OPTION.
- \*3: DISPLAY UNIT FOR BB-TYPE SHOULD BE PREPARED BY USER.
- \*4: SET THE JUMPER TO PIN #1/#3 AND #2/#4 BY EXTERNAL SWITCH (USER SUPPLY) FOR SHUTTLE FERRY MODE.

RSB-0070: 24rpm  
RSB-0073: 48rpm

4

3

2

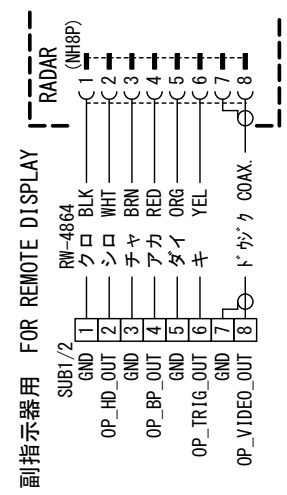
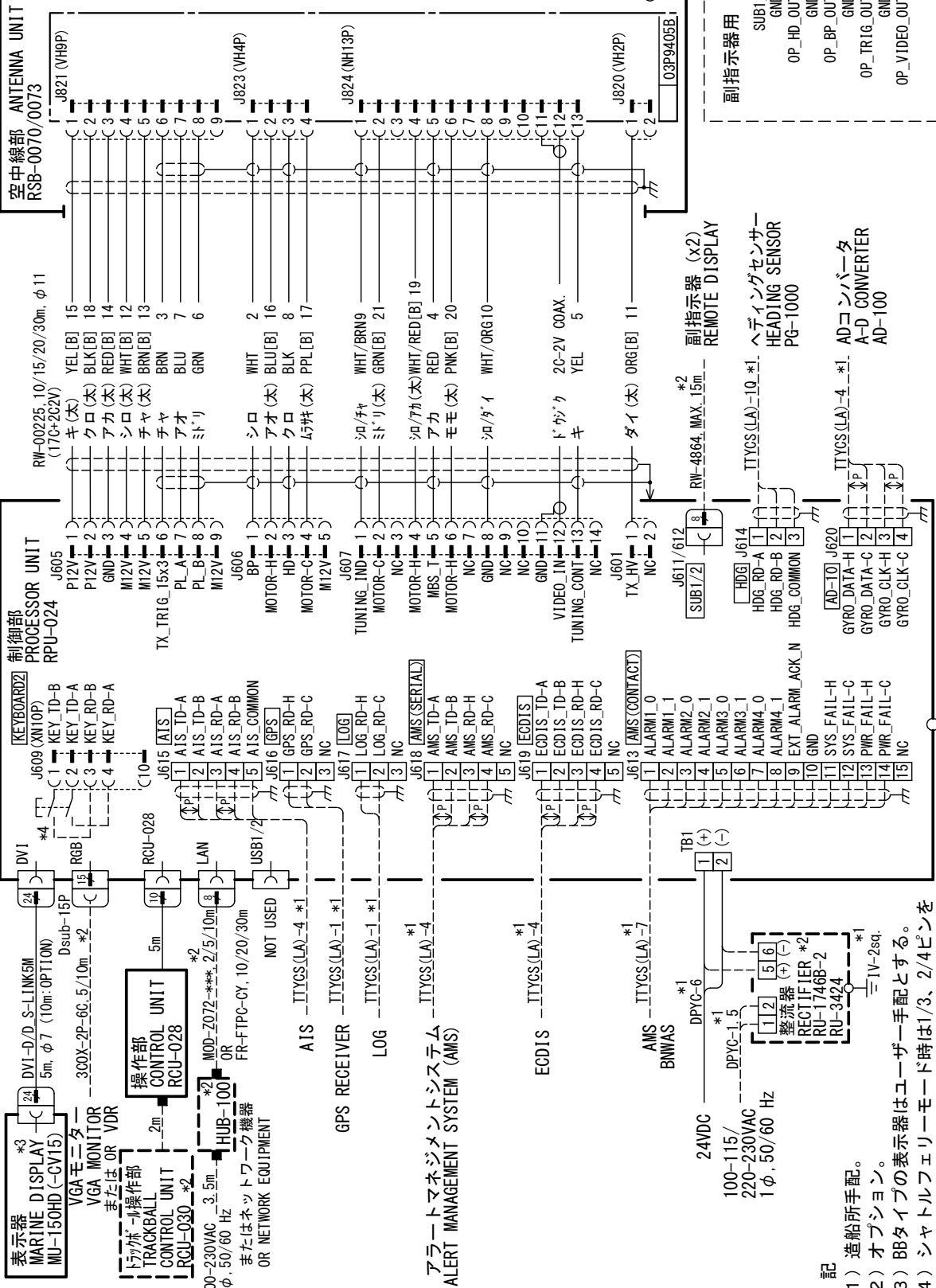

DRAWN	29/Sep/2016	T. YAMASAKI	TYPE	FAR-1523 (-BB)
CHECKED	30/Sep/2016	H. MAKI	名称	船舶用レーダー
APPROVED	30/Sep/2016	H. MAKI		相互結線図
SCALE	1/MASS	kg	NAME	MARINE RADAR
DWG. No.	C3639-001-E	REF. No.	03-186-6002-0	INTERCONNECTION DIAGRAM

FURUNO ELECTRIC CO., LTD.

- 注記
- \*1) 造船所手配。
  - \*2) オプション。
  - \*3) BBタイプの表示器はユーザー手配とする。
  - \*4) シャトルフェリーモード時は1/3、2/4ピンを外部スイッチ (ユーザー手配) でジャンパーする。

NOTE

- \*1: SHIPYARD SUPPLY.
- \*2: OPTION.
- \*3: DISPLAY UNIT FOR BB-TYPE SHOULD BE PREPARED BY USER.
- \*4: SET THE JUMPER TO PIN #1/#3 AND #2/#4 BY EXTERNAL SWITCH (USER SUPPLY) FOR SHUTTLE FERRY MODE.

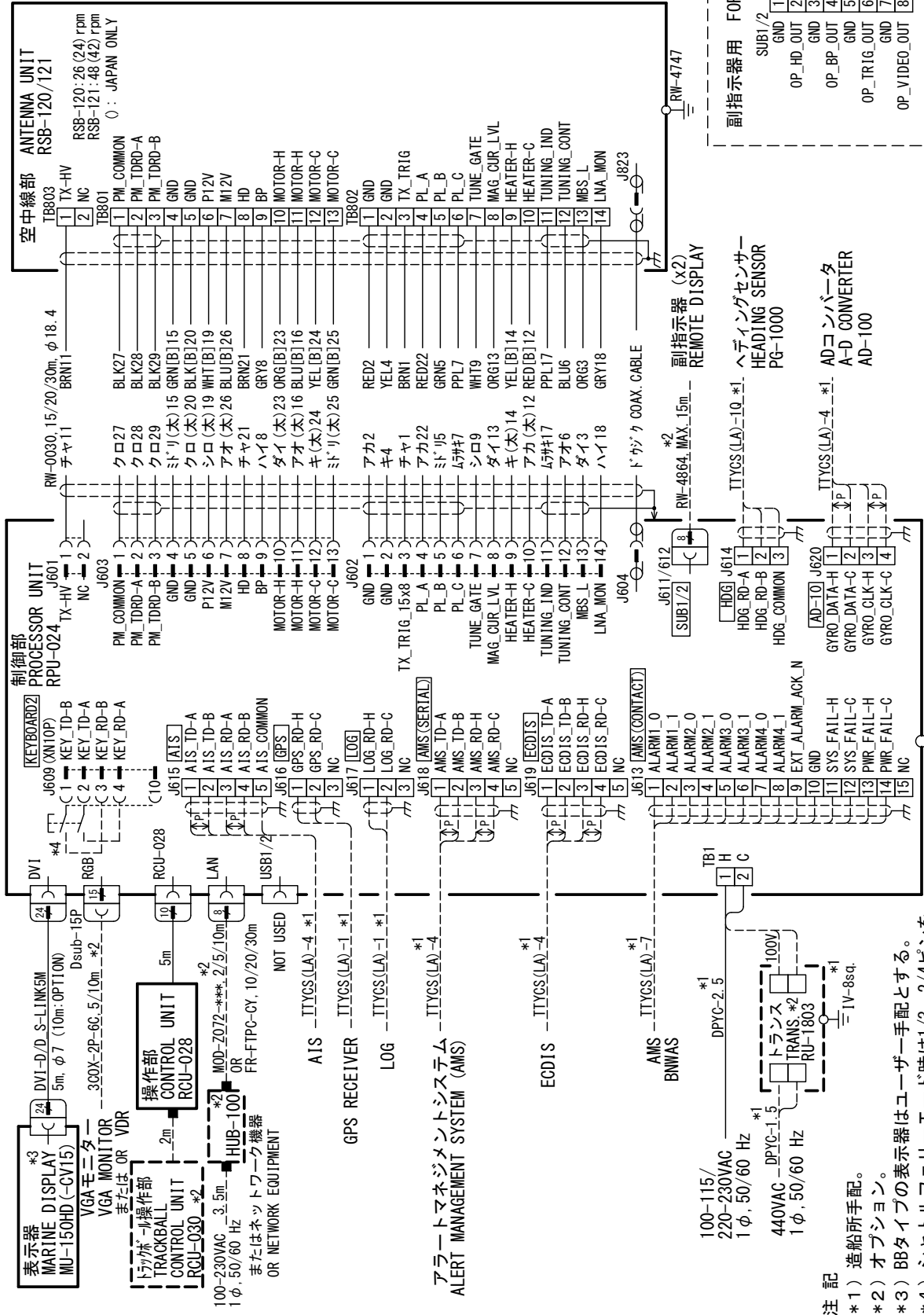

100-230VAC 3.5m  
1φ, 50/60 Hz

100-230VAC 220-230VAC 1φ, 50/60 Hz

440VAC DPYC-1.5 1φ, 50/60 Hz

100V TRANS. #2 RU-1803 1φ, 50/60 Hz

1V-8sq.

1V-8sq.

1V-8sq.

**注記**

- \*1) 造船所手配。
- \*2) オプション。
- \*3) BBタイプの表示器はユーザー手配とする。
- \*4) シャトルフェリーモード時は1/3、2/4ピンを外部スイッチ (ユーザー手配) でジャンパーする。

**NOTE**

- \*1: SHIPYARD SUPPLY.
- \*2: OPTION.
- \*3: DISPLAY UNIT FOR BB-TYPE SHOULD BE PREPARED BY USER.
- \*4: SET THE JUMPER TO PIN #1/#3 AND #2/#4 BY EXTERNAL SWITCH (USER SUPPLY) FOR SHUTTLE FERRY MODE.

DRAWN	29/Sep/2016	T. YAMASAKI	TYPE	FAR-1518/1528 (-BB)
CHECKED	30/Sep/2016	H. MAKI	名称	航海用レーダー (AC仕様)
APPROVED	30/Sep/2016	H. MAKI		相互結線図
SCALE	MASS	kg	NAME	MARINE RADAR (AC)
DWG. No.	C3642-001-E	REF. No.	03-186-6004-0	INTERCONNECTION DIAGRAM

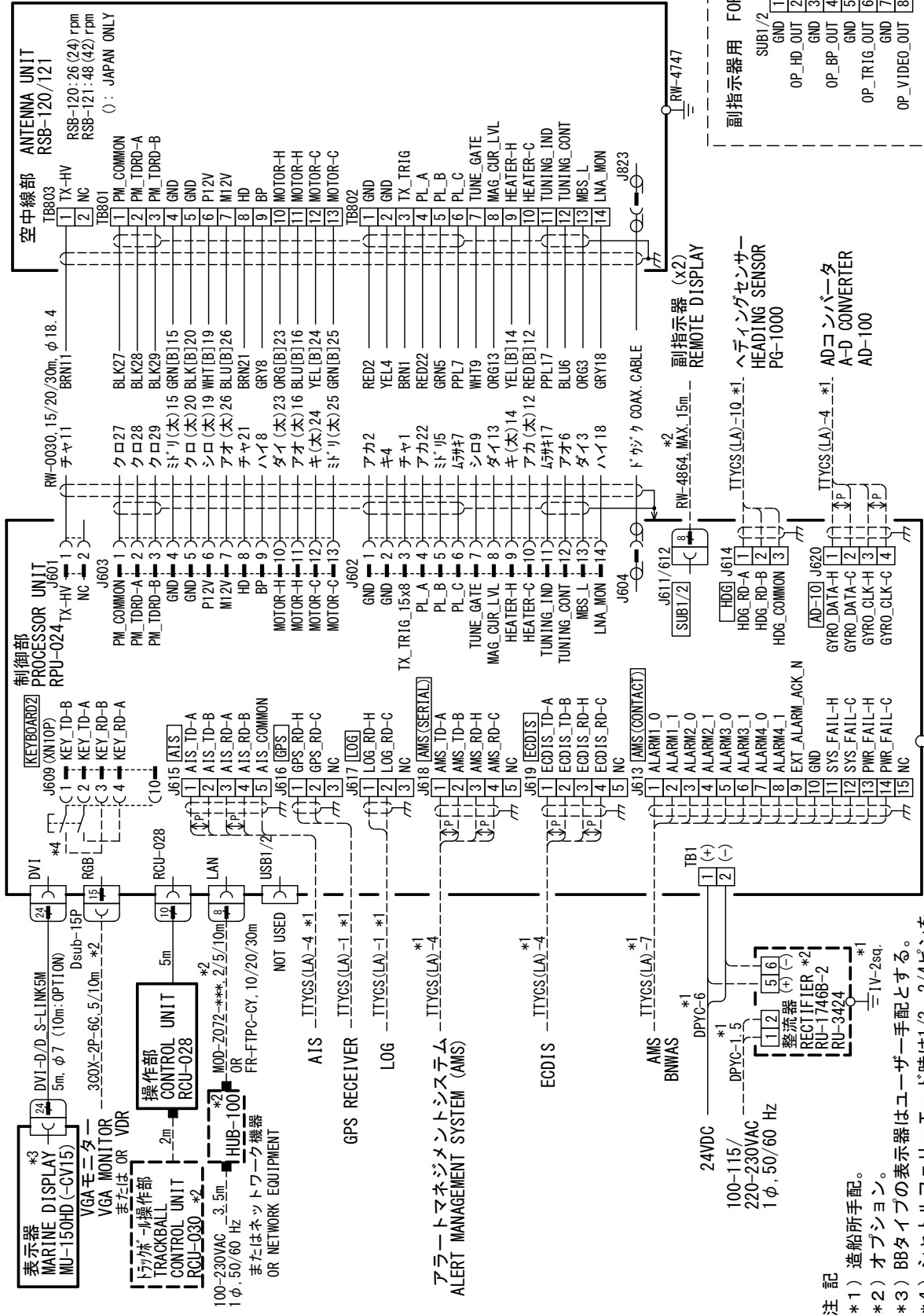

外部スイッチ (ユーザー手配) でジャンパーする。

NOTE  
\*1: SHIPYARD SUPPLY.  
\*2: OPTION.  
\*3: DISPLAY UNIT FOR BB-TYPE SHOULD BE PREPARED BY USER.  
\*4: SET THE JUMPER TO PIN #1/#3 AND #2/#4 BY EXTERNAL SWITCH (USER SUPPLY) FOR SHUTTLE FERRY MODE.

DRAWN	29/Sep/2016	T. YAMASAKI	TYPE	FAR-1518/1528 (-BB)
CHECKED	30/Sep/2016	H. MAKI	名称	航海用レーダー (DC仕様)
APPROVED	30/Sep/2016	H. MAKI		相互結線図
SCALE	MASS	kg	NAME	MARINE RADAR (DC)
DWG. No.	C3642-002-E	REF. No.	03-186-6003-0	INTERCONNECTION DIAGRAM