

# **FURUNO**

# **INSTALLATION MANUAL**

**MARINE RADAR**

---

**MODEL FR-8051/8111/8251**

---



**FURUNO ELECTRIC CO., LTD.**  
**NISHINOMIYA, JAPAN**

**©FURUNO ELECTRIC CO., LTD.**

9-52, Ashihara-cho,  
Nishinomiya, Japan 662

Telephone: 0798-65-2111  
Telefax: 0798-65-4200

-Your Local Agent/Dealer

All rights reserved. Printed in Japan

FIRST EDITION : NOV 1995  
F : AUG. 25, 1998

(TATA)

PUB. No. IME-34240-F  
FR-8051/8111/8251





# SAFETY INFORMATION

"**DANGER**", "**WARNING**" and "**CAUTION**" notices appear throughout this manual. It is the responsibility of the installer of the equipment to read, understand and follow these notices. If you have any questions regarding these safety instructions, please contact a FURUNO agent or dealer.



**DANGER**

This notice indicates a potentially hazardous situation which, if not avoided, will result in death or serious injury.



**WARNING**

This notice indicates a potentially hazardous situation which, if not avoided, could result in death or serious injury.



**CAUTION**

This notice indicates an unsafe practice which, if not avoided, could result in minor or moderate injury, or property damage.



# DANGER



**This equipment uses high voltage electricity which can shock, burn or cause death.**

Only qualified personnel should work inside the enclosures.



# WARNING



**Turn off the radar power switch before servicing the antenna unit. Post a warning sign near the switch indicating it should not be turned on while the antenna unit is being serviced.**

Serious injury or death can result if the radiator starts rotating and strikes someone near the scanner unit.



**Wear a safety belt and hard hat when working on the antenna unit.**

Serious injury or death can result if someone falls from the scanner mast.



# WARNING

## Radio Frequency Radiation Hazard

The radar antenna emits electromagnetic radio frequency (RF) energy which can be harmful, particularly to your eyes. Never look directly into the antenna aperture from a close distance while the radar is in operation or expose yourself to the transmitting antenna at a close distance.

Distances at which RF radiation levels of 100 and 10 W/m exist are given in the table below.

**Note:** If the antenna unit is installed at a close distance in front of the wheel house, your administration may require halt of transmission within a certain sector of antenna revolution. This is possible—Ask your FURUNO representative or dealer to provide this feature.

Model	Radiator type	Distance to 100 W point	Distance to 10 W point	RF power density on antenna aperture
FR-8051 (X-band, 6 kW)	XN2 (4')	Nil	Nil	Not measured
	XN3 (6.5')	Nil	Nil	
	XN3A (6.5')	Nil	Nil	
	XN4A (8')	Nil	Nil	
FR-8111 (X-band, 10 kW)	XN2 (4')	Worst case 0.25 m*	Worst case 2.3 m*	11.0 W/m <sup>2</sup>
	XN3 (6.5')			9.6 W/m <sup>2</sup>
	XN3A (6.5')			9.6 W/m <sup>2</sup>
	XN4A (8')			6.7 W/m <sup>2</sup>
FR-8251 (X-band, 25 kW)	XN2 (4')	Worst case 0.6 m*	Worst case 3.25 m*	29.0 W/m <sup>2</sup>
	XN3 (6.5')			23.8 W/m <sup>2</sup>
	XN3A (6.5')			23.8 W/m <sup>2</sup>
	XN4A (8')			20.6 W/m <sup>2</sup>

\* UK DRA measured on FR-2810/2820. Other values by FURUNO.



# CAUTION



**Ground equipment to prevent electrical shock and mutual interference.**

**Confirm that the power supply voltage is compatible with the voltage rating of the equipment.**

Connection to the wrong power supply can cause fire or equipment damage. The voltage rating appears on the label at the rear of the display unit.

**Use only the supplied power cable.**

Use of other power cables (particularly a cables whose diameter is smaller than the supplied cable) can cause fire or short circuit.

**Use the correct fuse.**

Use of a wrong fuse can cause fire or equipment damage.

# TABLE OF CONTENTS

---

<b>SYSTEM CONFIGURATION .....</b>	<b>iii</b>
<b>EQUIPMENT LISTS .....</b>	<b>iv</b>
<b>MOUNTING .....</b>	<b>1</b>
Mounting the Scanner Unit .....	1
Mounting the Display Unit .....	4
<b>WIRING .....</b>	<b>5</b>
Wiring in the Scanner Unit .....	5
Wiring in the Display Unit .....	8
<b>EXTERNAL SIGNAL INPUT/OUTPUT .....</b>	<b>10</b>
Input from External Equipment .....	10
Output to External Equipment .....	11
<b>CHANGING POWER SPECIFICATIONS .....</b>	<b>14</b>
<b>ADJUSTMENT .....</b>	<b>15</b>
Initial, Installation Menus .....	15
Working With the INSTALL Menus .....	17
1. Tuning the Receiver .....	17
2. Sweep Timing Adjustment .....	17
3. Video Amplifier Input Level .....	18
4. Main Bang Suppression (MBS) .....	18
5. Heading Alignment .....	18
6. STC Curve Adjustment .....	19
7. Presetting the FUNCTION key .....	19
8. Preventing Transmission in an Area .....	20
9. Selecting Navigator .....	20
10. Other Items on the INSTALL Menus .....	20
11. Installation Checklist .....	21

**OUTLINE DRAWINGS**

Display Unit ..... **D-1**  
Scanner Unit ..... **D-2**  
Scanner Unit (assembling) ..... **D-3 – D-7**

**SCHEMATIC DIAGRAMS**

Interconnection Diagram ..... **S-1**  
Display Unit, General ..... **S-2**  
Scanner Unit General ..... **S-3**

# SYSTEM CONFIGURATION

Unit		FR-8051	FR-8111	FR-8251
Display unit		RDP-112		
Antenna unit (select one)	24 rpm	C2P7N2N	C2P7N2N	RSB-0014
	36 rpm	RSB-0063	RSB-0063	RSB-0064
Transceiver unit		RTR-043	RTR-044	RTR-045
Slotted antenna		XN2/XN3/XN3A/XN4A		

Power consumption		
FR-8051	FR-8111	FR-8251
75W	90W	130W

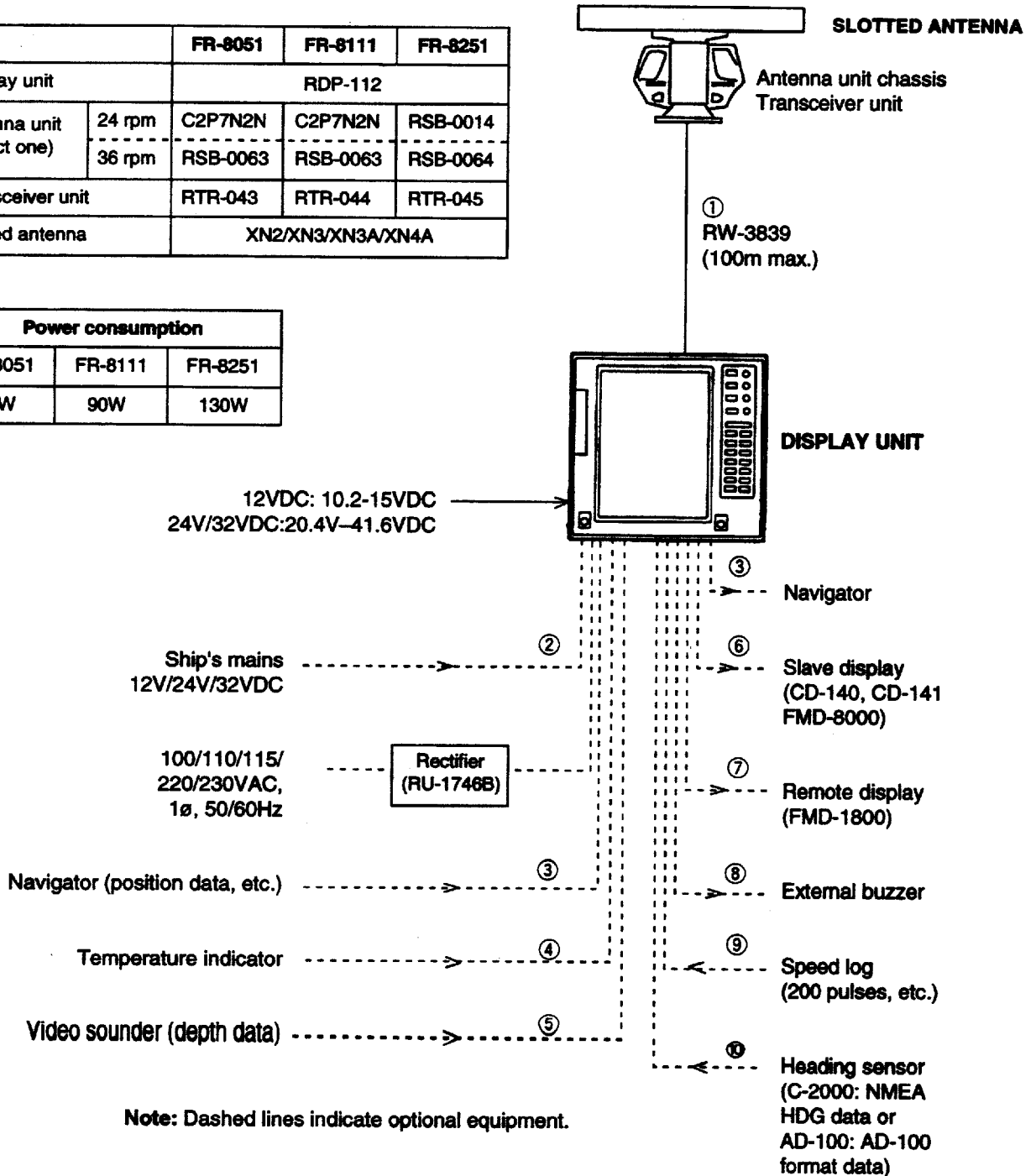

# EQUIPMENT LISTS

## Complete Set

Name	Type	Qty	Remarks
Scanner unit	See antenna table	1 set	24 rpm or 36 rpm
Display unit	RDP-112*	1	112A, 8051; 112B, 8111, 112C, 8251
Accessories	FP03-05310	1 set	Hood and filter
Display unit installation materials	CP03-15101	1 set	
Antenna unit installation materials	CP03-14401	1 set	
Signal cable	S03-53-*	1	Available in lengths of 15, 20, 25 and 30m
ML connector assy.	CP03-14202		For HV line connection
Display unit spare parts	SP03-11901	1 set	
Antenna unit spare parts	SP03-11102	1 set	

## Optional Equipment

No.	Name	Type	Code No.	Remarks
1	Signal cable	S03-55-5	008-455-160	w/XH-5P connector, 5m CO-2P cable
2	Interswitch unit	RJ-2	000-030-062	
3	Rectifier unit	RU-1746B-2	000-030-062	110VAC
			000-030-440	220VAC
4	Power cable	CVV-S 8 x 2C 15m	000-560-634	
5	Color display	CD-140	000-000-507	
		CD-1141	000-000-508	
6	Remote display	FMD-8010		
		FMD-1800		
7	Video plotter	GD-500/500 Mark 2		
8	External buzzer	OP03-21	000-030-097	
9	Vinyl cover	03-034-0401	000-801-657	
10	Auto plotter	ARP-15		
11	Video plotter	RP-15		
12	EMI filter	FP03-05500	008-456-990	
13	Hood w/lens	OP03-120	008-441-880	
14	Performance monitor	PM-30		

## Installation Materials for Scanner Unit

Name	Type	Code No.	Qty	Remarks
Ground wire	RW-4747 1 = 320 mm	000-566-000	1	For grounding scanner
Hex bolt	M12 x 60 SUS304	000-862-191	4	For mounting scanner
Hex nut	M12 SUS304	000-863-112	4	For mounting scanner
Flat washer	M12 SUS304	000-863-132	4	For mounting scanner
Spring washer	M12 SUS304	000-864-263	4	For mounting scanner
Hex bolt	M6 x 25 SUS304	000-862-180	1	For fastening ground wire
Hex nut	M6 SUS304	000-863-109	1	For fastening ground wire
Flat washer	M6 SUS304	000-864-129	3	For fastening ground wire
Spring washer	M6 SUS304	000-864-260	1	For mounting grounding wire
Crimp-on lug	FVD1.25-3, red	000-116-634	1	For coaxial cable (2C-2V)
Crimp-on lug	FV1.25-M3, red	000-538-110	26	For scanner terminal board
Crimp-on lug	FV5.5-4, yellow	000-538-123	2	For shield
Corrosion-proof rubber mat	03-001-3001-0 CR	300-130-010	1	For preventing galvanic corrosion
Seal washer	03-001-3002-0	300-130-020	4	For preventing galvanic corrosion

## Installation Materials for Display Unit

Name	Type	Code No.	Qty	Remarks
Crimp-on lug	FV2-4	000-538-118	4	For power cable
	8NK4	000-538-180	6	
Pan head screw	M3 x 10 C2700W MBN12	000-881-105	2	For fixing DJ connector
XH connector assy.	03-1768 (3P)	008-455-090	1	For connection of log
XH connector assy.	03-1798 (4P)	008-463-400	1	For connection of radar buoy
XH connector assy.	03-1796 (5P)	008-462-830	4	NAV I/O, E/S, AD-100

## Spare Parts for Display Unit

Name	Type	Code No.	Qty	Remarks
Fuse	FGBO 10A 125VAC	000-549-065	2	For 24/32VDC
Fuse	FGBO 20A 125VAC	000-549-015	2	For 12VDC

## Spare Parts for Scanner Unit

Name	Type	Code No.	Qty	Remarks
Carbon Brush	MG120-5x6x11 D8G	000-631-716	2	

## Antenna Unit/Antenna Radiator Combination

Model	Radiator	RPM	Antenna unit	Combination
FR-8051	XN2-B	24 rpm	C2P7N2N-043-S	XN2-C2P7N2N-043-S
	XN3-B			XN3-C2P7N2N-043-S
	XN3A			XN3A-C2P7N2N-043-S
	XN2-B	36 rpm	RSB-0063-044-S	XN2-RSB-0063-044-S
	XN3-B			XN3-RSB-0063-044-S
	XN3A			XN3A-RSB-0063-044-S
FR-8111	XN2-B	24 rpm	C2P7N2N-044-S	XN2-C2P7N2N-044-S
	XN3-B			XN3-C2P7N2N-044-S
	XN3A			XN3A-C2P7N2N-044-S
	XN4A			XN4A-C2P7N2N-044-S
	XN2-B	36 rpm	RSB-0063-044-S	XN2-RSB-0063-044-S
	XN3-B			XN3-RSB-0063-044-S
	XN3A			XN3A-RSB-0063-044-S
	XN4A			XN4A-RSB-0063-044-S
FR-8251	XN2-B	24 rpm	RSB-0014-045-S	XN2-RSB-0014-045-S
	XN3-B			XN3-RSB-0014-045-S
	XN3A			XN3A-RSB-0014-045-S
	XN4A			XN4A-RSB-0014-045-S
	XN2-B	36 rpm	RSB-0064-045-S	XN2-RSB-0064-045-S
	XN3-B			XN3-RSB-0064-045-S
	XN3A			XN3A-RSB-0064-045-S
	XN4A			XN4A-RSB-0064-045-S

## Cabling for Feeding Data to/from Display Unit

No. on page iii	Equipment	Cable required	Cable assy. code no.	Cable assy. type	Remarks
①	Scanner unit	S03-53-15 (15m) S03-53-20 (20m) S03-53-25 (25m) S03-53-30 (30m)	008-455-070 008-455-080 008-455-090 008-455-170	RW-3839	Select one. No armor, $\phi$ 18.4 See Note 1.
②	24V power	CVV-S 8 x 2C *15m*	000-560-634	CVV-S 8 x 2C	8sq, 15m, with shield
③	Navigator	S03-55-5 (03-1796(5P))	008-455-160	CO-SPEVV-SB-C 0.2 X 2P (5P)	NMEA data, for I/O
④ ⑤	Water temp, depth, HDG data (NMEA)	S03-55-5 (03-1796(5P))	008-455-160	CO-SPEVV-SB-C 0.2 X 2P (5P)	NMEA water temp., depth, heading data input
⑥	Slave display	S03-22-5 S03-22-10 S03-22-15	008-239-140 008-239-150 008-239-160	RW-4864 * 5M * RW-4864 * 10M * RW-4864 * 15M *	Supplied with slave display installation materials
⑦	Remote display	CVD Converter connected		RW-4864 * 0.6M *	Supplied with FMD-1800
⑧	External buzzer	OP03-21	000-030-097		
⑨	Speed log	(03-1768(3P))		250V-DPYC-1.25	Local supply
⑩	Gyrocompass	(03-1796(5P))		CO-SPEVV-SB -C 0.2x2P	Through AD-100

Note 1: If (existing) cable RW-3839 is to be used, attach high voltage connector assy. (CP03-14202, 008-461-490).

Note 2: Connector assy. 03-1796(5P) and 03-1768(3P) are supplied standard.

# MOUNTING

**⚠ DANGER**



**This equipment uses high voltage electricity which can shock, burn or cause death.**

Only qualified personnel should work inside the enclosures.

**⚠ WARNING**



**Turn off the radar power switch before servicing the antenna unit. Post a warning sign near the switch indicating it should not be turned on while the antenna unit is being serviced.**

Serious injury or death can result if the radiator starts rotating and strikes someone near the scanner unit.



**Wear a safety belt and hard hat when working on the antenna unit.**

Serious injury or death can result if someone falls from the scanner mast.

## Mounting the Scanner Unit

### Before beginning the installation...

- Secure an “off limits” area around the scanner mast to prevent injury due to falling objects.
- DO NOT lift the scanner unit by the radiator; use the lifting fixtures on the unit if it is necessary to hoist it to the mast.
- DO NOT paint the radiator surface.

### Siting considerations

- The scanner unit is generally installed either on top of the wheelhouse or on the radar mast on an appropriate platform, parallel with ship’s keel line. It should be placed where there is a good all-round view with, as far as possible, no part of the ship’s superstructure or rigging within the scanner’s vertical beamwidth (XN2/3, 25°; XN3A/4A, 20°)
- Five holes are required in the scanner unit platform: Four  $\phi 15$  mm for mounting of the scanner unit and one  $\phi 50$  mm for the signal cable.
- If there is a radio direction finder on the vessel, locate its antenna clear of the scanner unit, to prevent interference to the direction finder.
- Deposits and fumes from a funnel or other exhaust vent can adversely affect the aerial performance and hot gases tends to distort the radiator portion. The scanner unit must not be mounted where it may be subjected to temperatures in excess of 70°C.
- Observe the compass safe distances shown in Table 1 to prevent deviation of the magnetic compass.

*Table 1 Scanner unit compass safe distances*

Antenna unit	Standard compass	Steering compass
C2P7N2N (6 kW)	3.4 m	2.2 m
C2P7N2N (10 kW)	3.8 m	2.4 m
RSB-0014 (25 kW)	4.3 m	2.5 m

## Assembling

The procedure which follows provides general scanner unit assembly instructions. Assemble the unit by referring to the scanner unit outline drawing at the end of this manual.

- 1) Coat the waveguide flange with silicone sealant as shown in Figure 1.

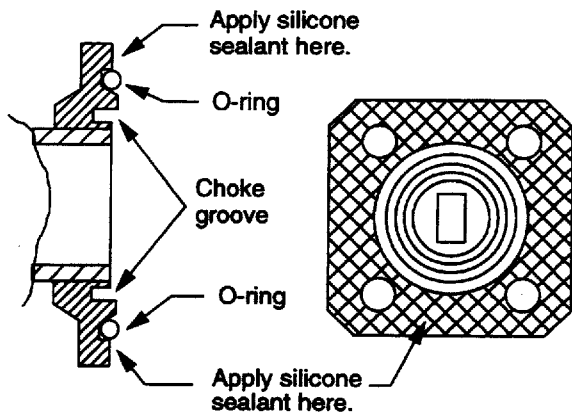

Evenly coat the waveguide flange with silicone sealant. Apply sealant sparingly; it leaks out slightly when the fixing bolts are tightened. Be sure no sealant contacts the choke groove and waveguide.

*Figure 1 How to coat the waveguide flange with silicone sealant*

- 2) Fix the feeder waveguide to the rotary joint.
- 3) Loosely fasten the antenna radiator to the rotary joint.
- 4) Fasten the feeder waveguide to the antenna radiator.
- 5) Fasten the feeder waveguide to the base of the antenna radiator.
- 6) Fasten the antenna radiator to the antenna bracket.

## Mounting

- 1) Lay the corrosion-proof rubber mat (supplied) on the mounting platform.

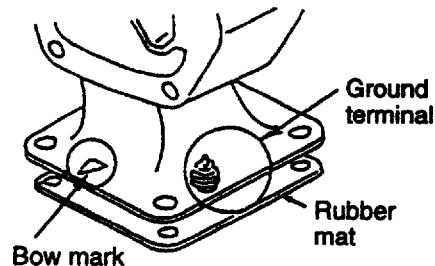

*Figure 2 Laying the rubber mat*

- 2) Hoist the scanner unit to the mounting location. Orient the scanner unit so the bow mark on the scanner unit faces ship's bow.

**DO NOT LIFT THE ANTENNA UNIT BY THE RADIATOR; LIFT IT BY THE HOIST RINGS. (REMEMBER TO REMOVE THE RINGS AFTER LIFTING.)**

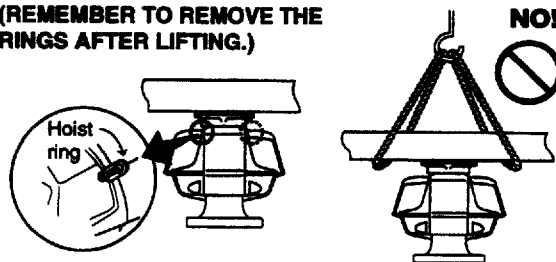

- 3) Fasten the scanner unit to the mounting platform with M12 x 60 hex bolts, seal washers and nuts.
- 4) Prepare ground point in mounting platform (within 300 mm of ground terminal on scanner unit) using M6 x 25 bolt, nut and flat washer.
- 5) Run the ground wire (RW-4747, 320 mm) between the ground terminal and ground point.

**CAUTION**

Ground the equipment to prevent electrical shock and mutual interference.

- 6) Coat ground terminal and ground point with silicone sealant as shown in Figure 3.

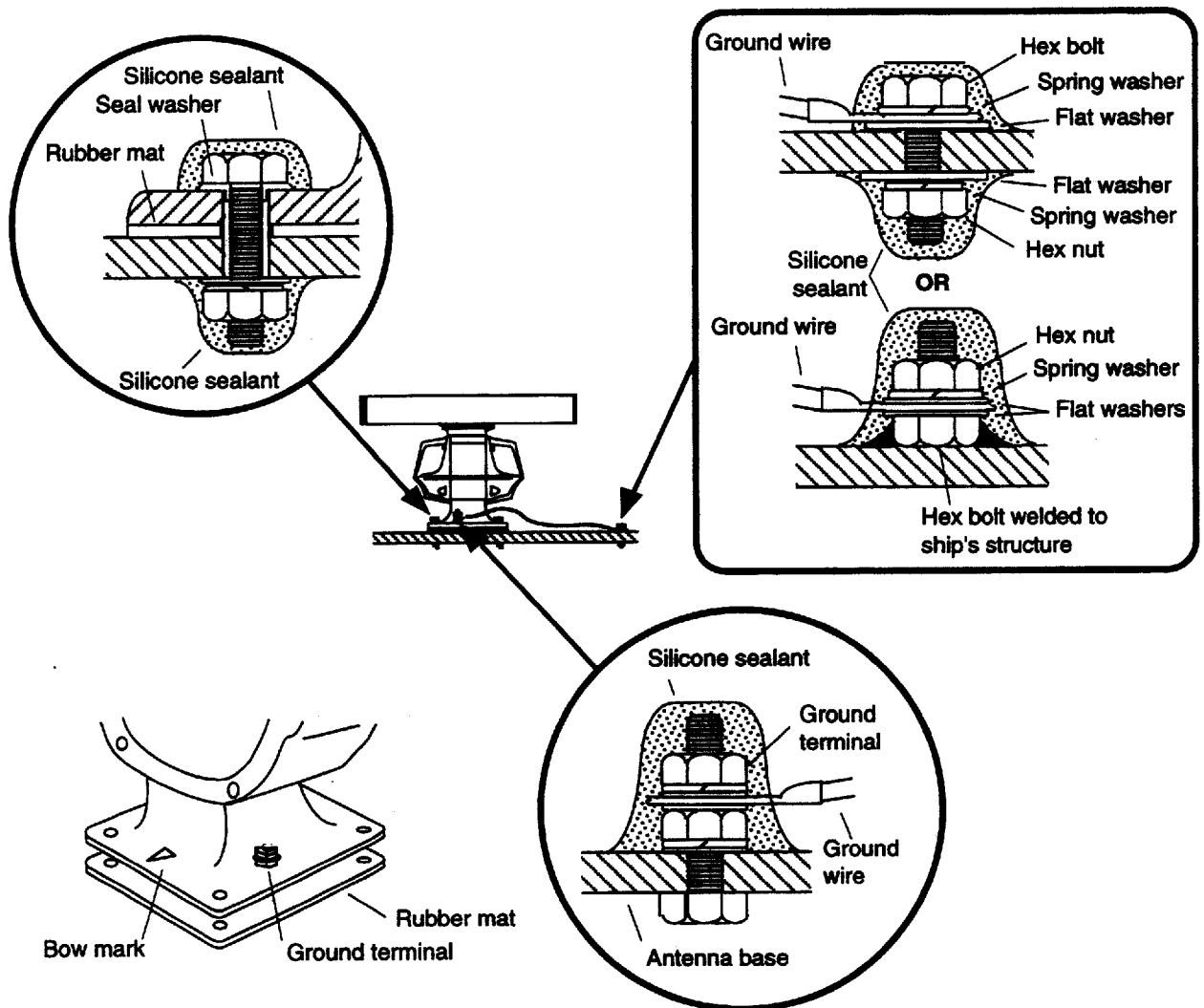

Figure 3 How to mount the scanner unit

# Mounting the Display Unit

## Siting considerations

- The display unit can be mounted on a tabletop, a bulkhead or on the overhead. Install it where it can be viewed and operated conveniently, but where it is protected from being sprayed or immersed in salt or fresh water.
- Observe the following display unit compass safe distances to prevent deviation of the magnetic compass;

*Table 2 Display unit compass safe distances*

	Standard compass	Steering compass
Display unit	1.3 m	1.0 m

- The display unit should be oriented so that you can view the screen while facing towards the bow. This will make determination of your position easier.
- The mounting location must be strong enough to support the display unit under vibration conditions normally encountered on the vessel. If necessary reinforce the mounting location.
- Determine the mounting location considering the length of the signal cable, which connects between the scanner unit and the display unit.
- Make sure you allow enough clearance to get to the connectors behind the unit. Leave at least a foot or so of "service loop" in cables so that it can be pulled forward for servicing or easy removal of the connectors.

## Tabletop mounting

- 1) Unfasten the two M8 x 40 bolts at the front of the display unit. Remove the fixing plate.
- 2) Mark screws locations in the tabletop by using the fixing plate as a template. **For mounting by bolts and nuts**, drill four holes of 12 mm diameter in the tabletop.
- 3) Secure the fixing plate to the tabletop by  $\varnothing 9$  coach screws or M10 bolts, nuts and washers.
- 4) Lay the display unit on the fixing plate. Secure it with the two M8 x 40 bolts unfastened in step 1.

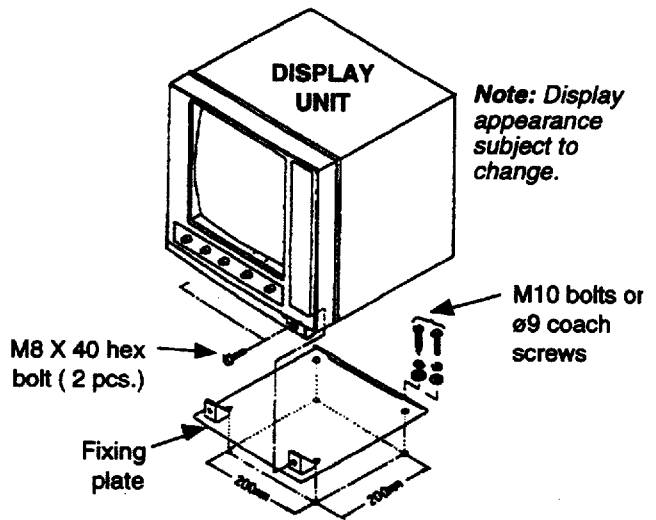

*Figure 4 Tabletop mounting*

## Overhead mounting

- 1) Referring to Figure 5, change the location of the fixing plate, mounting base, bottom plate and cover to mount the unit on the overhead.

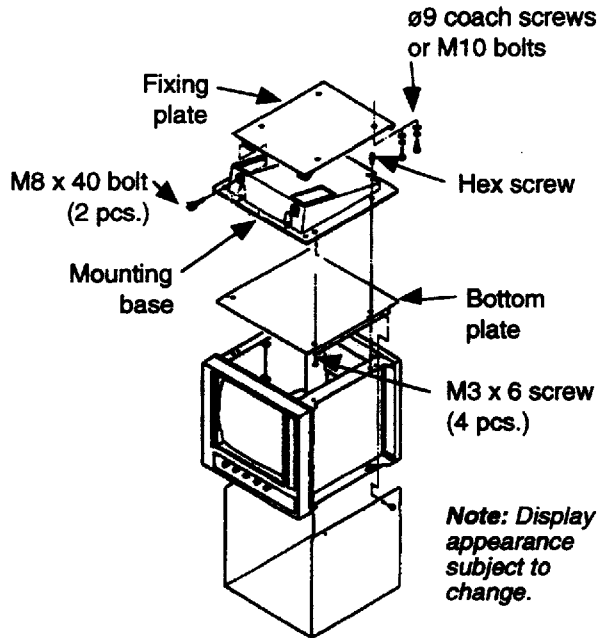

Figure 5 Display unit overhead mounting

# WIRING

## Wiring in the Scanner Unit

### Handling the transceiver unit

The transceiver unit contains the magnetron. The magnetron will demagnetize if it contacts magnetic material. When dismantling the transceiver, lay it atop non-magnetic material or lay it on its side, to prevent demagnetization. See Figure 6.

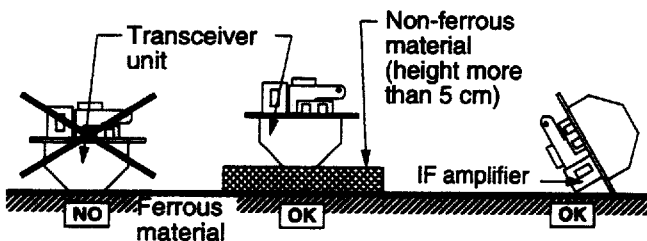

Figure 6 How to set the transceiver to prevent magnetron demagnetization

### **! Magnetron demagnetization**

The magnetron will demagnetize if it contacts ferrous material.

Lay the magnetron on its side or on top of non-ferrous material.

### Wiring

- 1) Open the scanner unit cover.
- 2) Disconnect plugs P801 and P601.
- 3) Unfasten the transceiver unit fixing bolts and dismount the transceiver unit from the scanner unit.

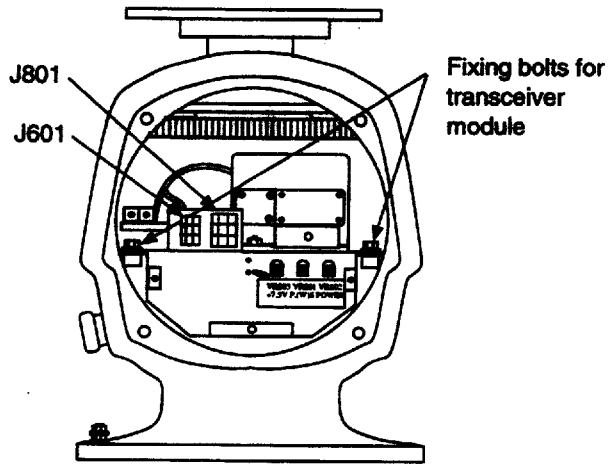

Figure 7 Transceiver unit, front view

- 4) Unfasten four fixing bolts on the cable gland at the base of the scanner unit. Remove clamping ring, rubber gasket and flat washers (2) from cable gland. See Figure 7.
- 5) Pass the signal cable through the cable entry hole in the scanner unit mounting platform. Shorten the cable so about 80 cm of it protrudes out of the cable gland.
- 6) Slide the flat washer, rubber gasket, flat washer and clamping ring onto the cable in that order.

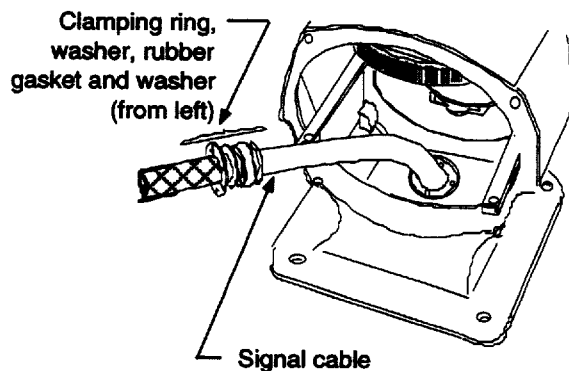
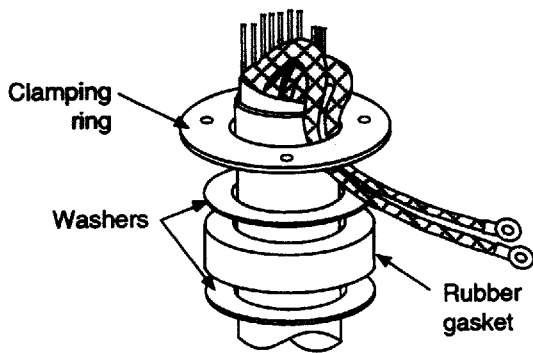

Figure 8 Passing cable gland assembly materials onto signal cable

- 7) Fabricate the signal cable as shown on page 7. Make the length of the cable a little longer than necessary to prevent damage to the coaxial cable.
- 8) Pass the outer and inner shields between the signal cable and the clamping ring. Fasten the cable gland.



*Figure 9 Passing shields between clamping ring and signal cable*

- 9) Connect the signal cable to the terminal board RTB801 by referring to the inter-connection diagram.
- 10) Bind cores with cable ties as shown in Figure 10.

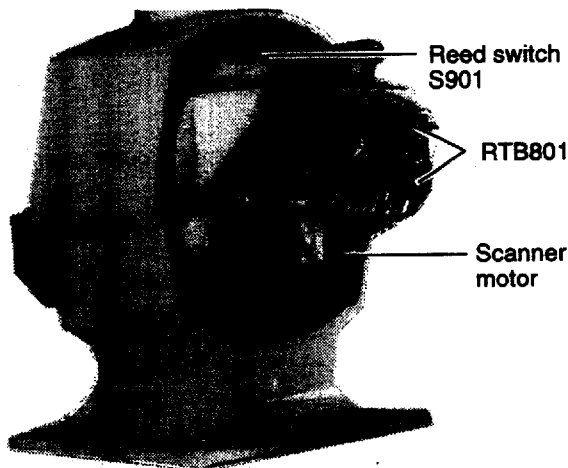

*Figure 10 Scanner unit, rear view, cover opened*

- 11) Install the transceiver unit. Connect plugs P801 and P601. Fasten the shields (inner and outer combined) to the ground terminal on the transceiver unit.

- 12) If the scanner is mounted leftward of the ship's bow line by up to 2°, turn on reed switch S901. (It is electrically connected to P902 #1 and #2 on the BRG SIG GEN Board MP-3795).

- 13) Confirm that all screws are tightened and all wiring is properly made.

- 14) Coat waterproofing gasket, bolts and tapping holes of scanner unit with silicone grease as shown in Figure 11.

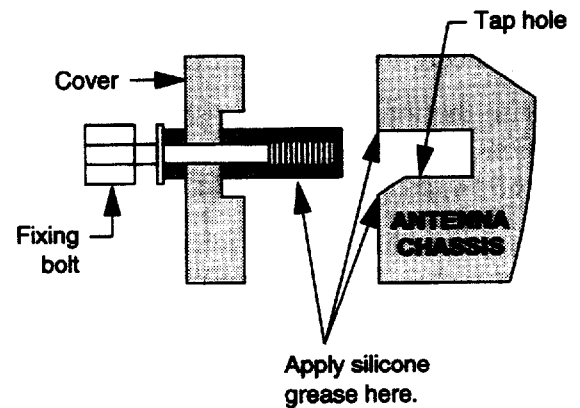

*Figure 11 Coating scanner unit cover with silicone grease*

- 15) Confirm that the waterproofing gasket is seated as shown in Figure 12.

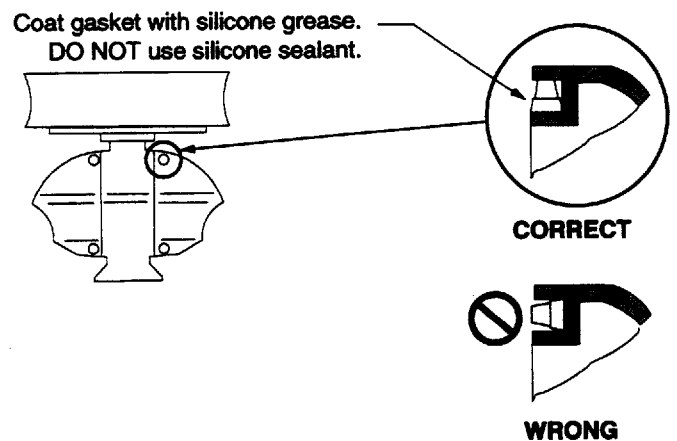

*Figure 12 Seating of waterproofing gasket*

### Fabricating signal cable RW-3839

- 1) Remove the vinyl sheath by 450mm.
- 2) Slide the clamping ring, washer, rubber gasket and washer onto the signal cable in that order.
- 3) Unravel the outer shield to expose the cores in the outer layer. Then, unravel the inner shield to expose the cores in the inner layer. Label all inner cores to aid in identification.
- 4) Trim each core (except coaxial wire) considering its location on the terminal board.
- 5) Trim the inner and outer shields leaving 50cm each. Attach crimp-on lug FV5.5-4 (yellow,  $\phi 4$ ) to each shield.
- 6) Remove insulation of each core by 6 mm approximately. Fix crimp-on lug FV1.25-M3 (red,  $\phi 3$ ) to each core.
- 7) Fabricate the coaxial wire as shown in g) and h) in Figure 13. Make the length of the wire 10mm longer than the shield to prevent wire strain. Attach crimp-on lug FVD1.25-3 (red,  $\phi 3$ ) to the coaxial wire and FV1.25-M3 to the shield.

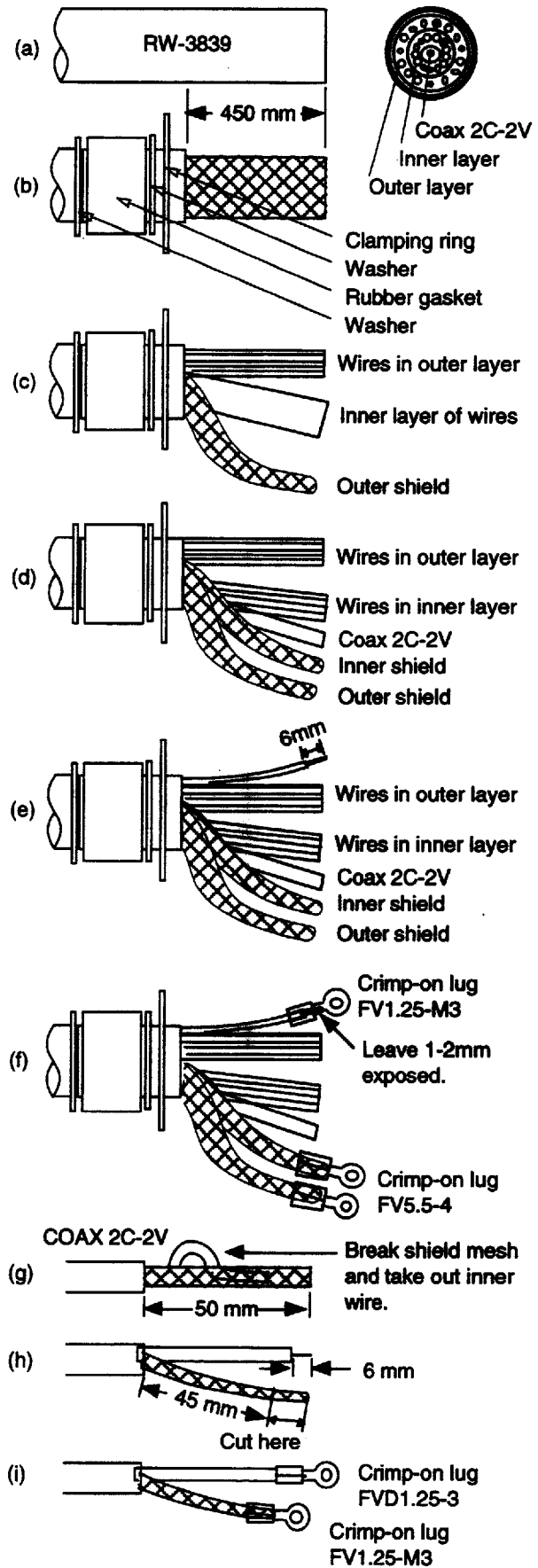

Figure 13 Fabricating signal cable RW-3839

## Wiring in the Display Unit

At least two cables are terminated at the display unit: the signal cable and the power cable. The signal cable, which is available in lengths of 15 meters, 20 meters, 25 meters or 30 meters, comes prefitted with a connector for connection to the display unit.

Proper grounding of cables cannot be stressed enough; be sure to ground the shield of cables by the cable clamp.

**Note:** ML connector assembly is available when used with existing signal cable. See equipment list.

## Fabricating the power cable CVV-S 8 x 2C (optional supply)

- 1) Remove the vinyl sheath by 40 mm.
- 2) Unravel the braided shield to expose the cores.
- 3) Remove insulation of cores by about 10 mm.
- 4) Fix crimp-on lugs to the cores and braided shield.

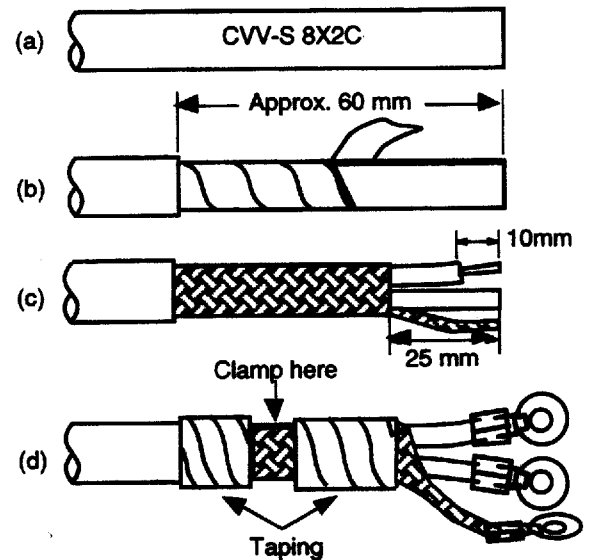

Figure 14. How to fabricate the power cable (CVV-S 8 x 2C)

## Laying cables inside the display unit

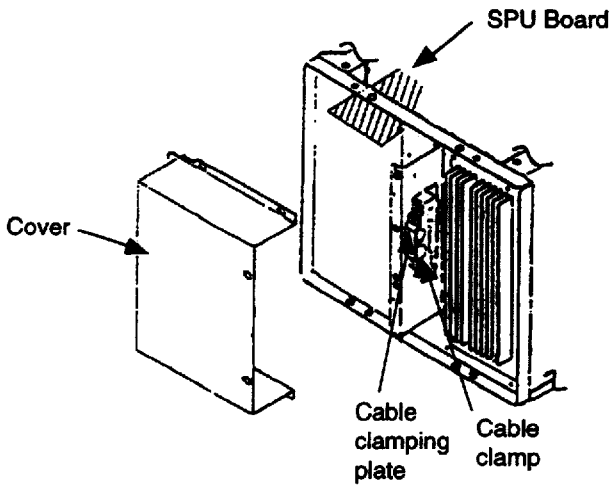

Figure 15 Display unit, rear view, cover removed

- 1) Remove the display unit cover.
- 2) Dismount the clamping plate from the cable clamp by loosening two screws.
- 3) Lay the signal cable and power cable inside the cable clamp. Fasten the clamping plate to the cable clamp by using two M4 x 12 screws. If optional equipment are connected, secure the clamping plate by using two M6 x 30 bolts.

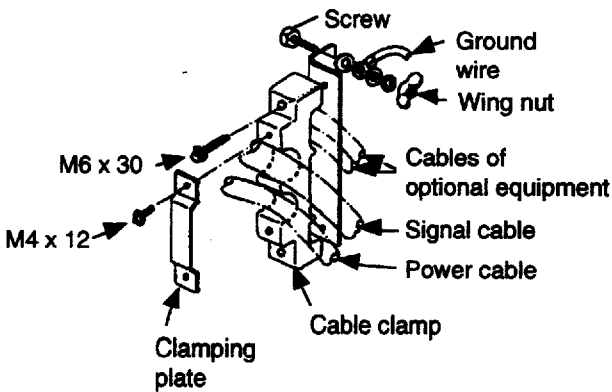

Figure 16 Laying cables in the cable clamp

- 4) Connect the power cable and signal cable by referring to the interconnection diagram. Fasten shields of those cables to chassis.

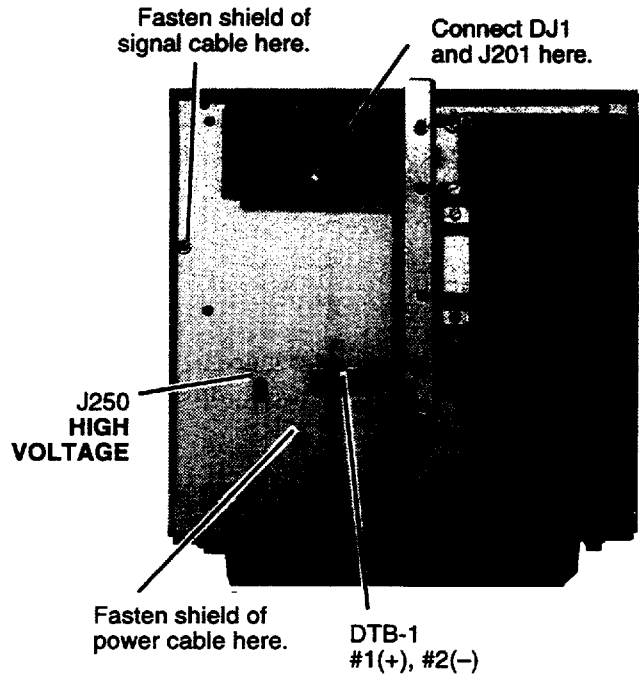

Figure 17 Display unit, rear view

- 5) Run a ground wire (IV-8 sq, or equivalent) from the ground terminal to nearest ground point.

# CAUTION

Ground the equipment to prevent electrical shock and mutual interference.

It is recommended to seal the cable gland (with aluminum tape, etc.) to keep foreign objects out of the display unit.

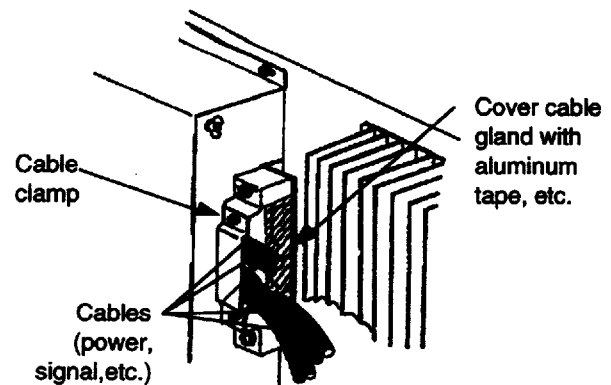

Figure 18 Sealing the cable gland

# EXTERNAL SIGNAL INPUT/OUTPUT

## Input from External Equipment

As shown in Figure 20, this radar accepts inputs from a wide variety of equipment. All external equipment are connected to the SPU Board, which is near the DJ connector at the rear of the display unit. Use XH connector assy. to connect external equipment. FURUNO can provide a signal cable assembly; 5m, 2-pair cable with XH-5 connector attached.

*Table 3 Connector wiring*

Terminal no.	Wire color	
1	BROWN	pair
2	RED	
3	ORANGE	pair
4	YELLOW	
5	BLACK	

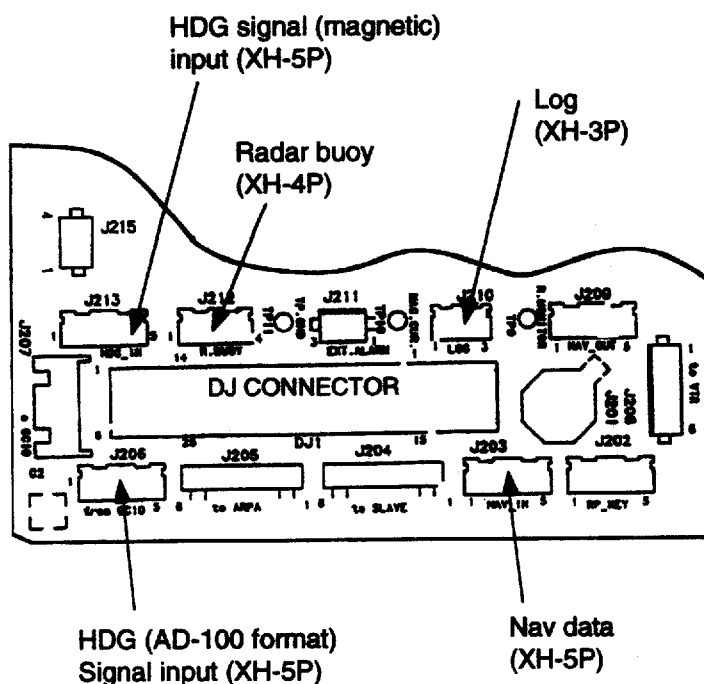
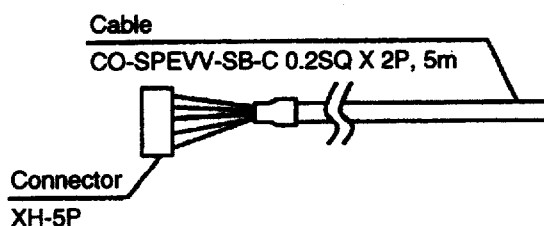

*Figure 19 Location of connectors on the SPU Board*

**Table 4 External signal output connector (SPU Board)**

Signal	Connector	Connector no.	Connector type	Equipment (example)	Remarks
Heading signal	HDG IN	J213	XH, 5 pin	C-2000	HDG (NMEA format)
Speed log signal	LOG	J210	XH, 3 pin	DS-70, DS-30, MF-220, CI-60	200 pulses/nm, etc.
Nav data (L/L, wpt, time, TD, course, water temp., depth)	NAV IN	J203	XH, 5 pin	GP-3100, GP-50M2, GP-188, FCV series, T-2000, TI-20	(*1)
Remote display input signal	—	DJ1	28 pin		When used to connect a slave display, input heading, bearing, video and trigger signals through DJ connector.
Radar buoy signal	for R. BUOY	J212	XH, 4 pin		
Heading, water temp., depth	HDG IN	J213	XH, 5 pin	T-2000, TI-20	(*2)

\*1 Requires interface (IF-2901, etc.) to input position, water temperature and depth.

\*2 HDG IN connector can accept water temperature or depth data (NMEA) in lieu of heading signal.

## Output to External Equipment

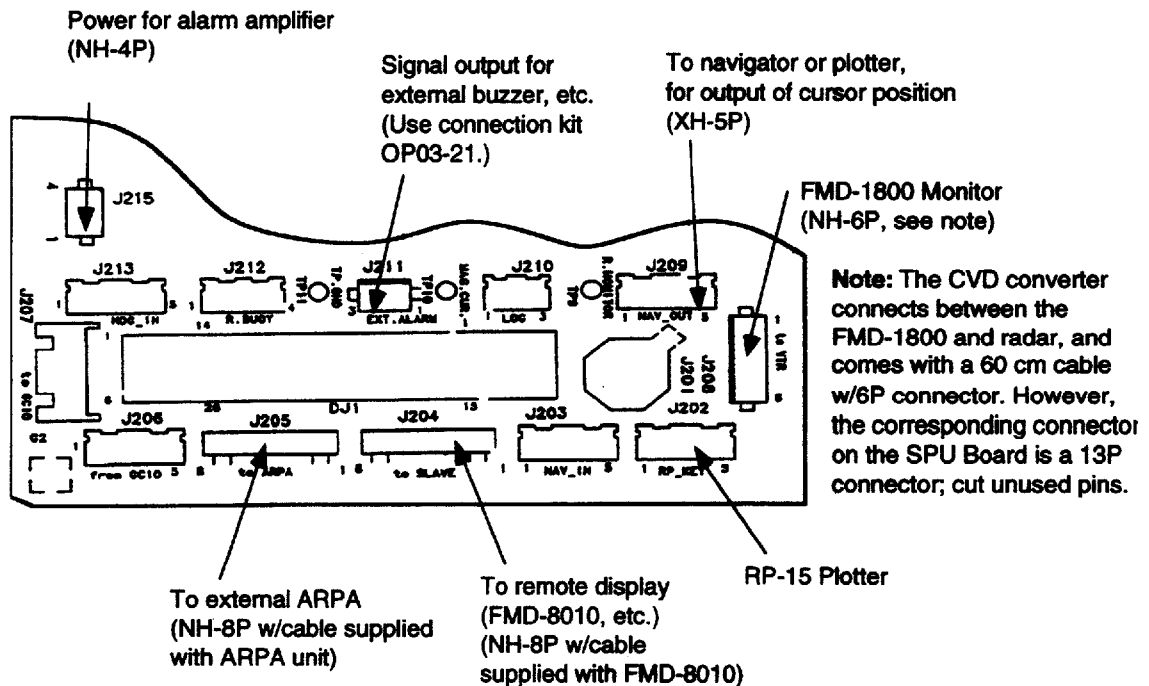

**Figure 20 Location of external equipment connectors on the SPU Board**

*Table 5 External signal output connector (SPU Board)*

Signal	Connector	Connector no.	Connector type	Equipment (example)	Remarks
ARPA signal	to ARPA	J205	NH, 8 pin	FA-2800, etc.	heading marker, bearing, video, tx trigger
Remote display signal	to SLAVE	J204	NH, 8 pin	CD-140, CD-141, GD-500, FMD-811, FMD-8010 (*)	heading marker, bearing, video, true trigger
Alarm signal	EXT ALARM	J211	NH, 3 pin	OP03-21-3	Buzzer drive signal
				Speaker w/amp	Speaker signal
Monitor signal	to VTR	J208	NH, 6 pin	FMD-1800	Horizontal synch, vertical synch, video (NTSC format)
Radar signal (serial data)	NAV OUT	J209	XH, 5 pin	To navigator (plotter)	NMEA 0183 \$RATLL \$RARSD

\* Display unit for FR-8051/8111/8251 can be used as slave display unit.

### Connection of external speaker, buzzer

An external speaker or buzzer can be connected to this radar via an amplifier circuit (local supply), as shown in the figure below. Ground the amplifier to nearby connector's ground terminal.

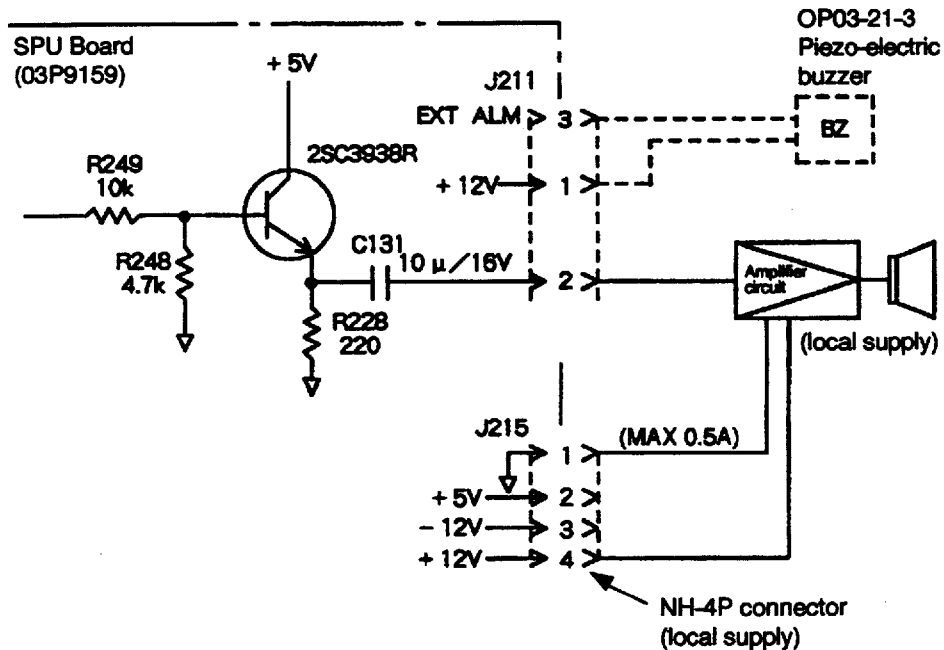

*Figure 21 Connection of external speaker or buzzer to the SPU Board*

## NMEA I/O data

The FR-8000 series accepts the following nav data input/output sentences.

Table 6 Receivable NMEA0183 sentences

Input/Output	Receive sentence
Speed	RMA>RMC>VTG>VHW
Heading (true)	HDT>VHW>HDG>VHW>HDM
Heading (magnetic)	HDM>VHW>HDT>HDG>
Course (true)	RMA>RMC>VTG
Course (magnetic)	VTG>RMA>RMC
Waypoint (range/bearing)	RMB>BWC>BWR
Ship's position	RMA>RMC>GLL
Loran TD	RMA>GLC>GTD
Time	ZDA
Water temperature	MDA>MTW

Table 7 Transmittable NMEA0183 sentences

Input/Output	Transmit sentence
Target position (cursor latitude and longitude)	RAATLL
Radar system data *	RARSD
Target message ** when equipped w/ARP-15	RATTM

\* Origin mark range and bearing, EBL bearing, VRM range, cursor range and bearing, etc.

\*\* Target no., range, bearing, course, speed, CPA, TCPA, etc. Outputted from J2#1 and J#2 on the ARP Board.

# CHANGING POWER SPECIFICATIONS

This radar can be powered by 12V, 24V or 32V power. (12V operation is available for FR-8051/8111, but is not available with the FR-8251 or the 36 rpm scanner unit.) Power specification can be changed from 12V to 24V/32V and vice versa by attaching jumper wire JP1 and changing the power fuse F1351.

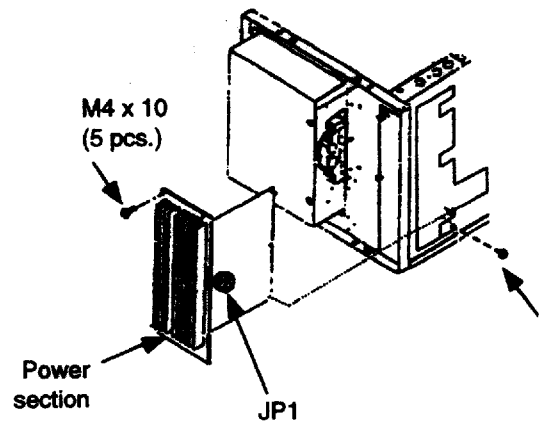

Figure 22 Display unit, rear view

- 3) Unplug connectors on the POWER Board and remove the board.
- 4) Attach jumper wires as shown in below. Jumper JP1 is on underside of the transformer.

### 12V DC spec.

Attach jumper wires between ①-②, ③-④, ⑤-⑥, and ⑦-⑧.

### 24V/32V DC spec.

Attach jumper wires between ②-③ and ⑥-⑦.



## CAUTION

**Connection to the wrong power supply can cause fire or equipment damage.**

Confirm that the power supply voltage is compatible with the voltage rating of the equipment. The voltage rating appears on the label at the rear of the display unit.

**Use of the wrong fuse can cause fire or equipment damage.**

Use the correct fuse.

### Input voltage rating (at terminal board in display unit)

12V DC: 10.2 to 15V DC  
 24V/32V DC: 20.4 to 41.6V DC

### Procedure

- 1) Remove the display cover.
- 2) Remove rear panel of display unit by unfastening five screws. Unfasten three screws securing the POWER Board.

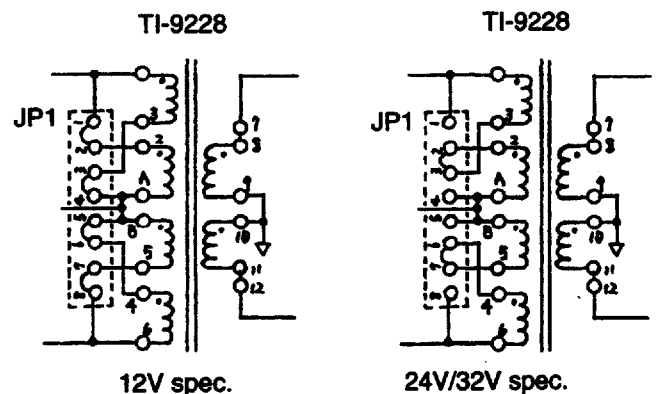

Figure 23 Location of jumper JP1 on transformer

- 5) Change fuse as follows.  
 12V DC spec.: 20A  
 24V/32V DC spec.: 10A
- 6) Reassemble the power section.

# ADJUSTMENT

## Initial, Installation Menus

Many presettings and adjustments are done on the INITIAL and INSTALL menus. Below and on the next page are menu trees for these menus. Factory settings shown in bold.

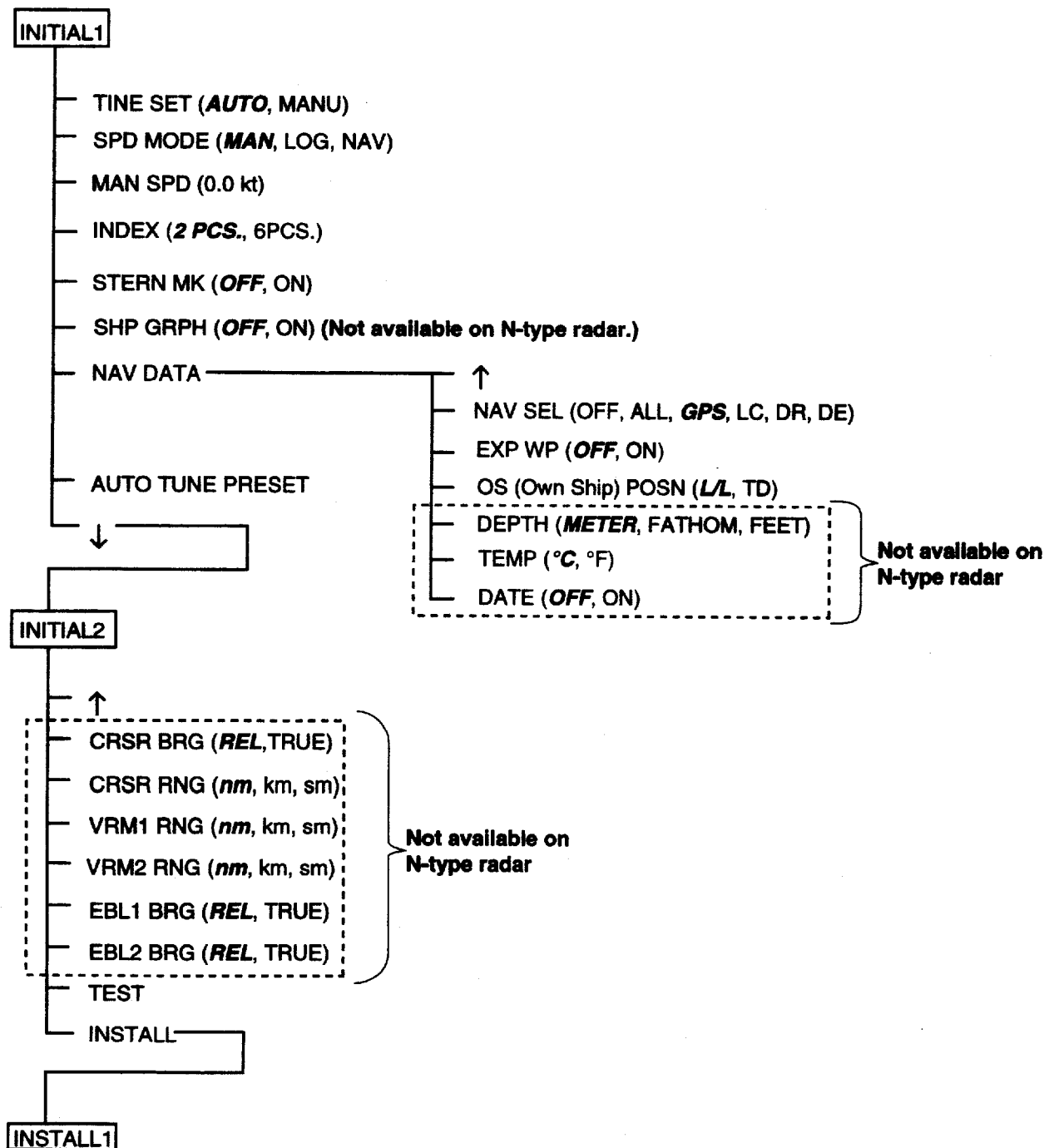

Figure 24 INITIAL menus

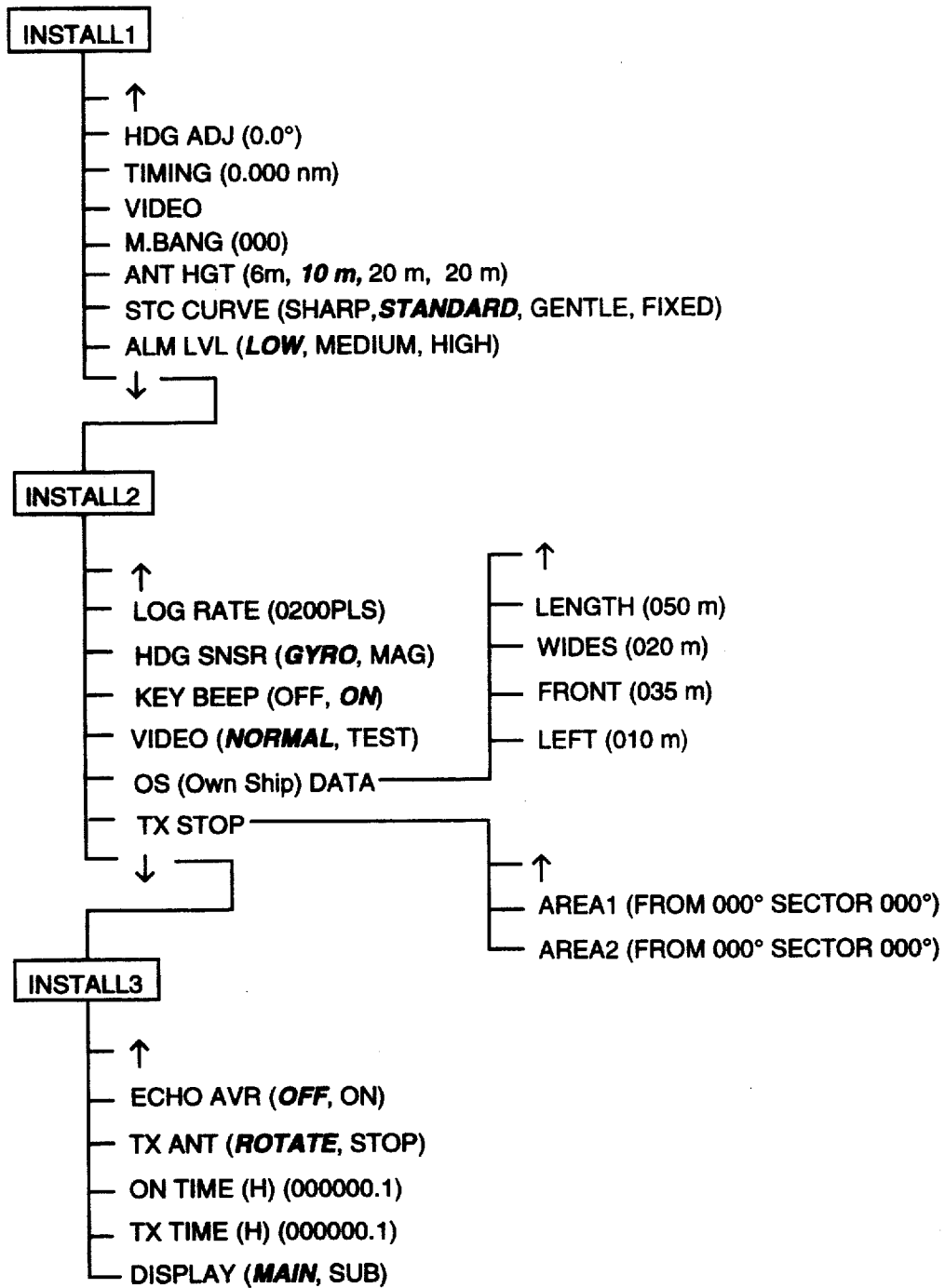

Figure 25 INSTALL menus

## Working With the INSTALL Menu

### Accessing the INSTALL menus

While pressing and holding down the [GAIN] control, turn on the power.

### Displaying the INSTALL menus

Press the [MENU] key about two seconds to display the INITIAL menu. Select INSTALL on the INITIAL2 menu and press the [ENTER] key.

### Selecting items on menus

- 1) Operate the VRM or EBL control to select menu.
- 2) Press the [ENTER] key.
- 3) Operate the VRM or EBL control to change setting.
- 4) Press the [ENTER] key.

### Closing the menu

Press the [MENU] key.

### Changing pages

**Next page:** Place cursor on ↓ and press the [ENTER] key.

**Previous page:** Place cursor on ↑ and press the [ENTER] key.

### Clearing wrong data

Press the [CLEAR] key.

## 1. Tuning the Receiver

### Initial setting

With the radar transmitting, do the following:

On the INITIAL1 menu, select TUNE SET and press the [ENTER] key. The unit automatically tunes the receiver, displaying the indication AUTO SETTING at the top of the menu while tuning. When tuning is completed, the indication disappears. (This procedure records both peak value for the TUNE indicator and automatic coarse tuning.)

## 2. Sweep Timing Adjustment

Sweep timing depends on the length of the signal cable (between the display unit and the scanner unit). Adjust it as shown in the procedure below to prevent pushing in pulling out of targets as shown in the Figure 26.

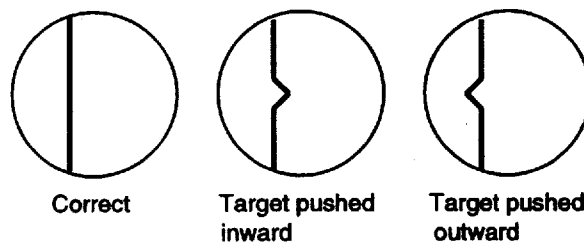

*Figure 26 Examples of proper and improper sweep timing*

- 1) Select TIMING on the INSTALL1 menu and press the [ENTER] key.
- 2) Transmit on the 0.125 nautical mile range, and visually select a target which forms right angles (harbor wall, etc.).
- 4) Operate the VRM control to straighten target selected in step 3. For reference, amount "straightened" in nautical miles appears at bottom right side on the display.
- 5) Press the [ENTER] key.

### 3. Video Amplifier Input Level

The longer the signal cable the lower the video amplifier level input and thus the smaller targets appear on the display. Do the following to adjust video amplifier level input.

- 1) Transmit on a long range.
- 2) On the INSTALL1 menu, select VIDEO and press the [ENTER] key.

At the top of the menu AUTO SETTING. appears. The indication disappears when adjustment is completed.

### 4. Main Bang Suppression (MBS)

Main bang, which appears at the display center on short ranges, can be suppressed as follows.

- 1) Transmit on long range about 10 minutes.
- 2) Adjust the gain to show a small amount of noise on the display.
- 3) Change to the 0.125 nautical mile range and adjust the [A/C SEA] control.
- 4) Select M. BANG on the INSTALL1 menu.
- 5) Press the [ENTER] key.
- 6) Operate the VRM control to suppress main bang
- 7) Press the [ENTER] key.

### 5. Heading Alignment

The scanner unit is mounted facing straight ahead in the direction of the bow. Therefore, a small but conspicuous target dead ahead visually should appear on the heading mark. In practice, however, there will be some error on the display because of the difficulty in achieving accurate initial positioning of the scanner unit. Do the following to compensate for error.

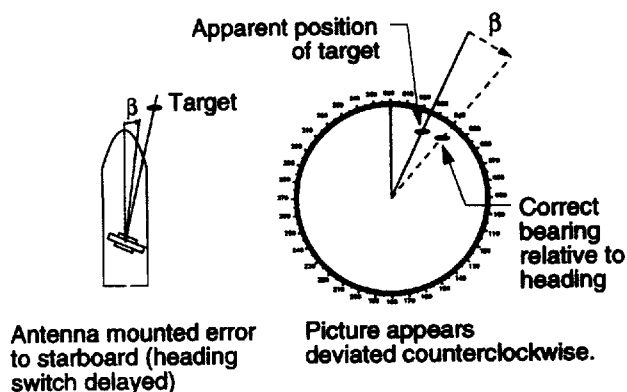
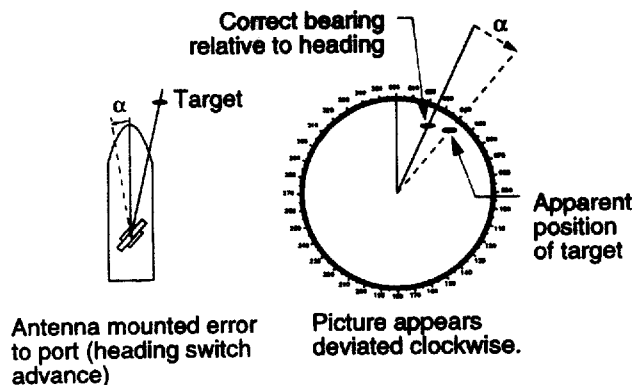

Figure 27 Minus heading error

- 1) Identify a suitable target (by gyrocompass, for example) at a range between 0.125 to 0.25 nautical miles, preferably near the heading mark.
- 3) Open the INSTALL1 menu and select HDG ADJ.
- 4) Press the [ENTER] key.
- 5) Operating the VRM control, bisect the target by the EBL. The value at the bottom right of the menu shows antenna position in relation to ship's bow (0°).
- 6) Press the [ENTER] key.

## 6. STC Curve Adjustment

Open the INSTALL1 menu and enter antenna height and best STC curve.

**Antenna height:** Enter antenna height above the waterline, as accurately as possible.

**STC curve:** Select STC curve by expected average sea conditions.

## 7. Presetting the FUNCTION key

The [FUNCTION] key provides one-touch adjustment of STC, pulselength, and other controls. Eight types of target setups are available (see Table 8) and three can be preset on the FUNC menu.

- 1) Press the [FUNCTION] key and select function number (FUNC1, FUNC2, or FUNC3) to set.
- 2) Select FUNC on the main menu.
- 3) Place the cursor on the FUNC SEL.

FUNC ( 1 )			
FUNC		STRETCH	P/L SEL
	S1	OFF	OFF
ECHO	AVG	A/C AUTO	
	OFF	OFF	
INTRF		NOISE	
	OFF	OFF	

It is recommended to maintain default settings for STRETCH, P/L SEL, ECHO AVG, A/C AUTO, INTRF and NOISE. They are optimally set considering target objective, thus any change may prevent obtainment of objective.

To restore default settings, select appropriate function again and close the menu.

*Figure 28 Function setting menu*

- 4) Press the [ENTER] key.

- 5) Operate the VRM control to select settings.

- 6) Press the [ENTER] key.

To set another function number (2 or 3), erase the menu and then repeat steps in the previous procedure.

**Note:** When the main menu displays FUNC KEY\*, this means no function is active and the [FUNCTION] key is inoperative. To select a function, erase the menu and press the [FUNCTION] key.

Table 8 Function objectives

Item	Description
S1 (Short range 1)	Short range navigation (within 1.5 nm); for example, when approaching a harbor.
S2 (Short range 2)	Short range navigation within 3 nm.
S & M (Short and Medium ranges)	General navigation on ranges within 12 nm.
L-ES (Long range-cho Stretch)	Magnify target echoes on 6 nm range and higher ranges.
L-STC (Long range-STC)	Suppress sea surface reflections on 3 nm range and higher ranges.
ES (Echo Stretch)	Magnify target echoes on 1.5 nm range and higher ranges.
B1 (Buoy 1)	Detect echoes from small targets (various buoys, small vessels, floats, etc.) on ranges within 1.5 nm.
B2 (Buoy 2)	Detect small targets on ranges greater than 1.5 nm.

## 8. Preventing Transmission in an Area

When the scanner is installed at a close distance in front of the wheelhouse and this presents an rf radiation hazard, the radar should be set to not transmit within that area. This feature can also be used to prevent transmission in a blind or shadow sector. Two areas can be set.

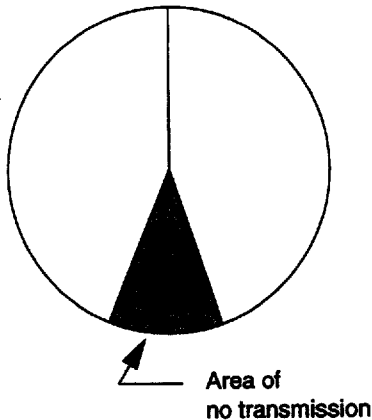

Figure 29 Example of no transmission area on the display

### Procedure

- 1) Display the INSTALL2 menu.
- 2) Select TX STOP.
- 3) Press the [ENTER] key.
- 4) Select AREA 1 or AREA 2.
- 5) Press the [ENTER] key.
- 6) Enter start of area by operating the VRM control.
- 7) Press the [ENTER] key.
- 8) Enter end of area by operating the VRM control.
- 9) Press the [ENTER] key.

### Deleting no transmission area

Enter 000° as end of area.

## 9. Selecting Navigator

On the INITIAL1 menu, select NAV SEL and navigator which feeds position data to the radar.

## 10. Other Items on the INSTALL Menus

Table 9 Other items on INSTALL menus

Item, INSTALL menu no.	Description
Alarm level, #2	Set echo strength which will trigger the guard alarm. Note that the HIGH setting can trigger alarm on sea clutter.
Log pulse ratio, #2	Enter log pulse ratio.
Heading sensor, #2	Select heading sensor which feeds heading data to the radar.
Key response, #2	Turn on or off key beep.
Video signal, #2	Normally set to NORMAL.
Own ship data, #2	Turn on SHP GRPH on the INITIAL1 menu, and enter own ship data to accurately depict own ship graphic (on the display) on INSTALL2 menu.
Transmitting while scanner is stopped, #2	Radar pulses can be transmitted with scanner rotation suspended, for servicing, etc.
Echo averaging and no gyro, #3	Turn off echo averaging when no gyro is connected.
Display unit function, #3	Select function of display unit: main or slave display.

## 11. Installation Checklist

After completing the installation, check it for completeness following the checklist shown below. Check asterisk-marked items if they apply to the installation.

- Tuning circuit adjustment
- Video level adjustment
- Main bang suppression
- Sweep timing adjustment
- Heading alignment
- Antenna height selection
- STC curve selection
- FUNCTION key presetting
- \*Entry of area of no transmission
- \*Selection of navigator
- Setting up of INITIAL menus
- \*Entry of log pulse ratio
- Setting up of INSTALL menus



**High voltage is present at the potentiometers for adjustment of the picture.**

Use a screwdriver having a non-metallic shank to adjust those potentiometers.

- 注 記 1) 装置ケーブルはサービス時、指示部を前方へ充分引き出せるよう余裕を持たせること。  
 2) 装置ケーブルの端未処理は、装置要領書参照のこと。  
 3) 取付用ネジはM10ボルトまたはコーチボルト呼び径φ9を使用のこと。  
 4) #印寸法は最小サービス空間寸法とする。

NOTE 1) SUFFICIENT EXTRA CABLING SHOULD BE ALLOWED AT THE BACK OF THE UNIT SO THAT THE UNIT CAN BE DRAWN OUT WITH THE CABLES CONNECTED FOR MAINTENANCE.  
 2) REFER TO INSTALLATION INSTRUCTION FOR FABRICATION OF CABLE ENDS.  
 3) USE M10 BOLTS OR #9 COACH SCREW FOR FIXING THE UNIT.  
 4) # : RECOMMENDED SERVICING CLEARANCE.

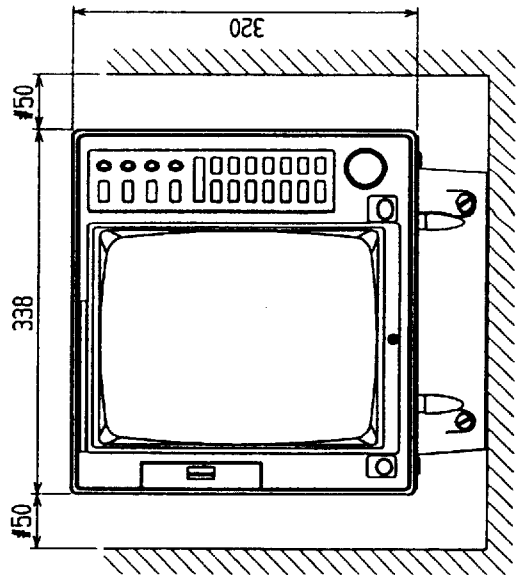
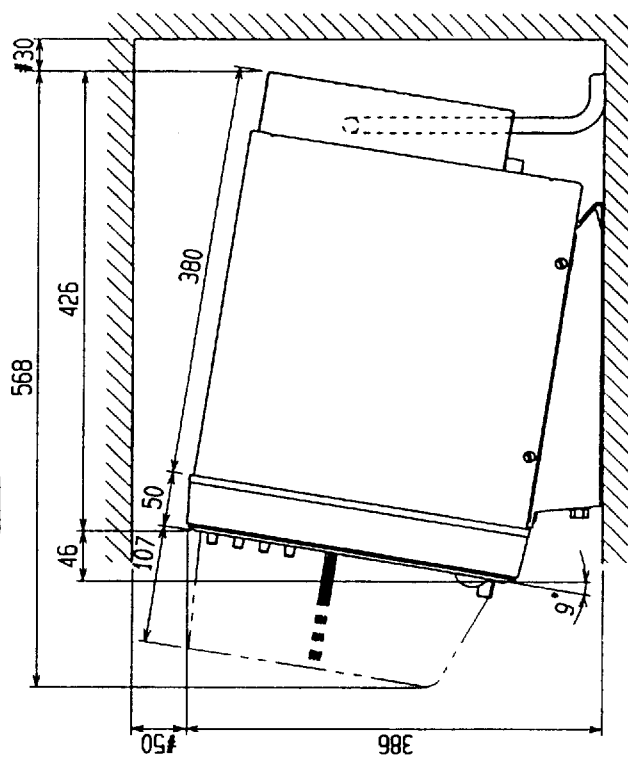
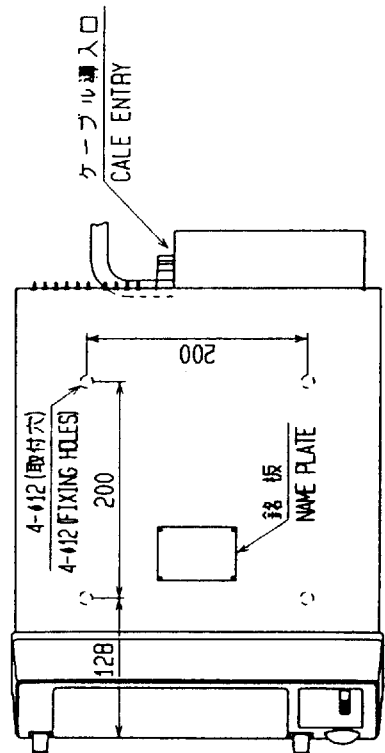

DRAWN	K. Kusunoki	TYPE	RDP-112/112M
CHECKED	S. J. K. Okamoto	名称	指示部
APPROVED	K. Okamoto	外寸図	
SCALE	1/5	BLOCK NO.	
PLANT	14.5 kg (MODEL)	NAME	DISPLAY UNIT
DWG. NO.	C3423-601-A		OUTLINE DRAWING

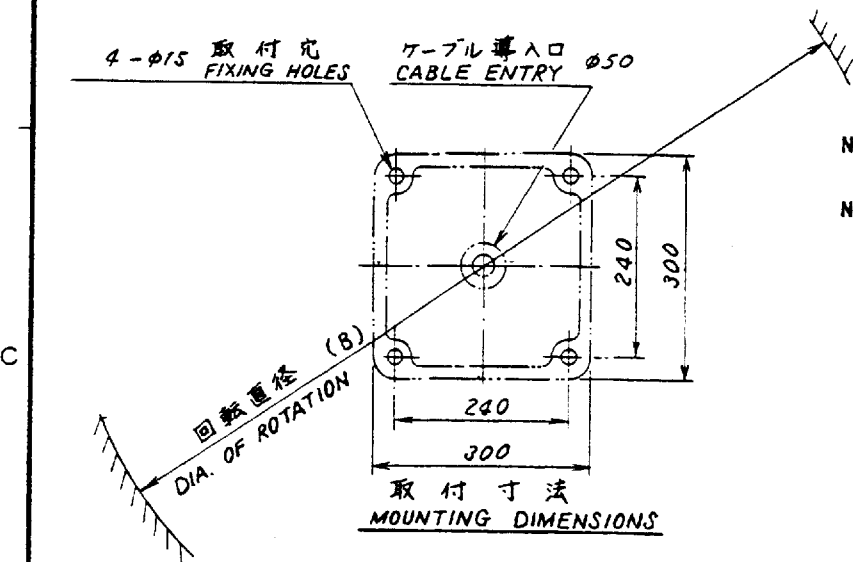
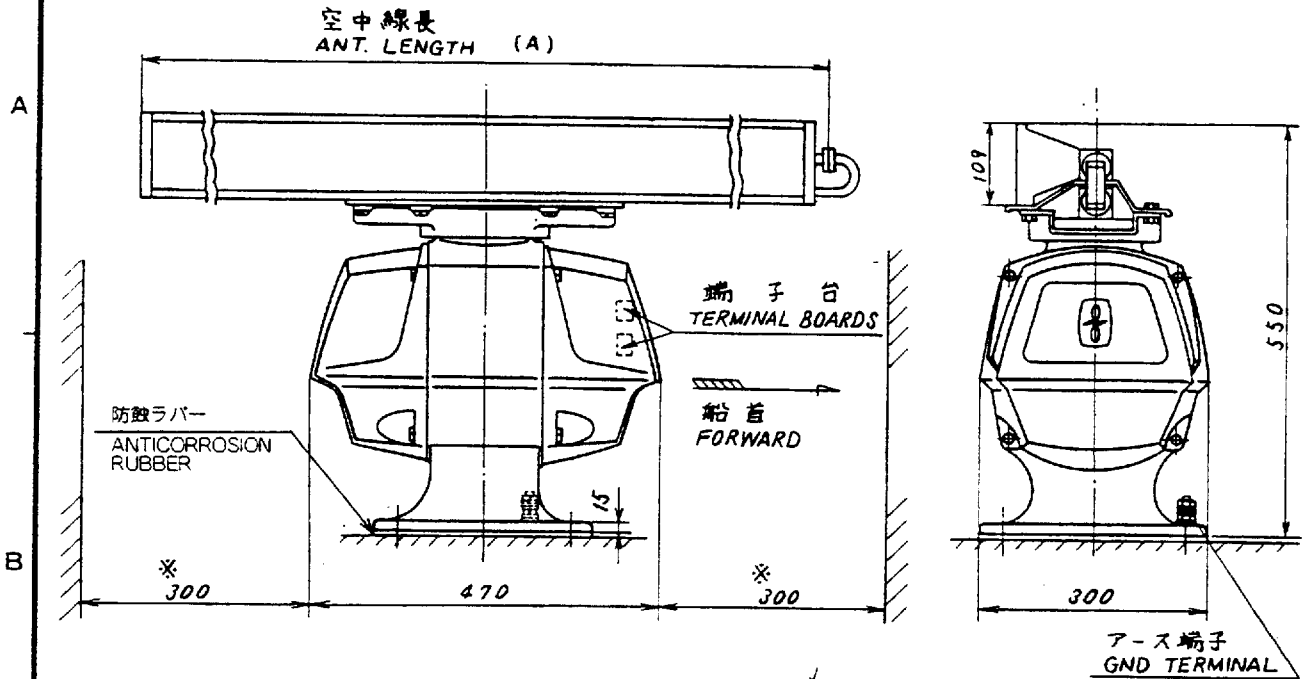

NOTE 1. ※: 推奨するサービス空間  
RECOMMENDED SERVICE CLEARANCE.

NOTE 2.

アンテナ型式 ANT. TYPE **	XN2	XN3
空中線長 (A) ANT. LENGTH	1250 mm	2000 mm
回転直径 (B) DIAMETER OF ROTATION	1400 mm	2200 mm
質量 MASS	33 kg	37.5 kg

\*\*選択可能な空中線部種類はレーダー型式により異なる。各仕様を参照のこと。

SELECTABLE ANTENNA TYPE DEPENDS ON RADAR MODEL. SEE INDIVIDUAL SPECIFICATIONS.

NOTE 3. 取付台の平面度は±1mm以内のこと。

THE SURFACE OF PLATFORM SHOULD BE EVEN WITHIN ±1 mm.

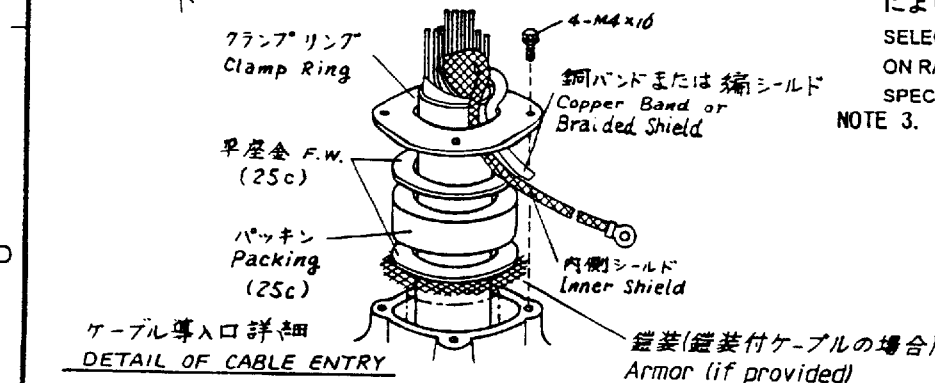

DRAWN Jan 12 '92 T. Yamaguchi		TYPE RSB0063/C2P7N2N/C2P8N2N
CHECKED Jan 14 '93 H. Kikuchi		名称 空中線部
APPROVED Jan 14 '92 F. Yamaguchi	FR1510M2 FR2110	外寸図
SCALE MASS kg	APPLICABLE TO: (MODEL)	BLOCK NO.
DWG. NO. C3237-001-V		NAME RADAR SCANNER UNIT
		OUTLINE DRAWING

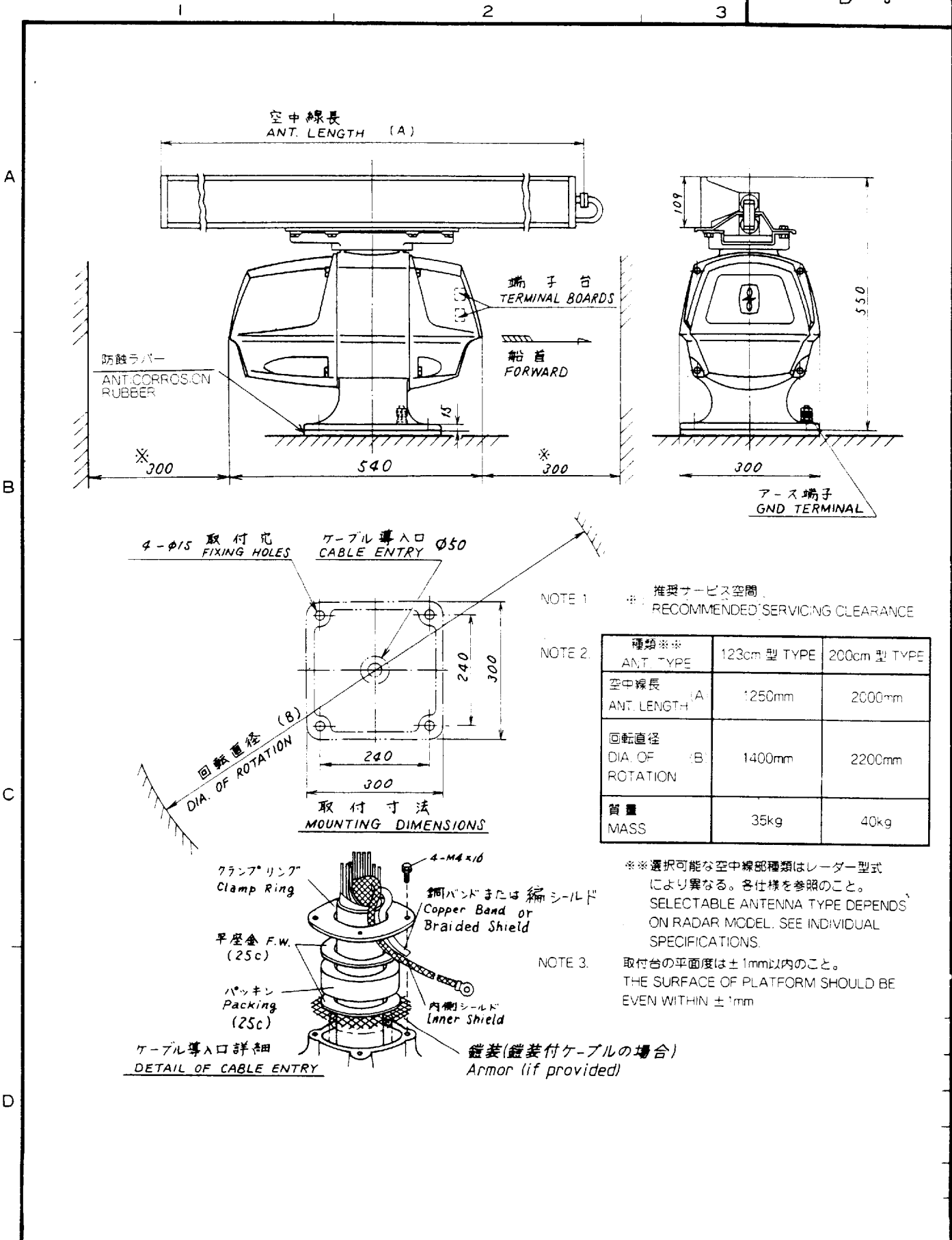

REMARKS XN 2 / 3				TYPE RSB0014 / RSB0064
DRAWN K.M	APPROVED 1/10/00	FR1525M2 FR2120		名称 空中線部
SCALE 1/10	MASS kg	APPLICABLE TO: (MODEL)	BLOCK NO.	NAME RADAR SCANNER UNIT
				DWG NO. C3290-004- J

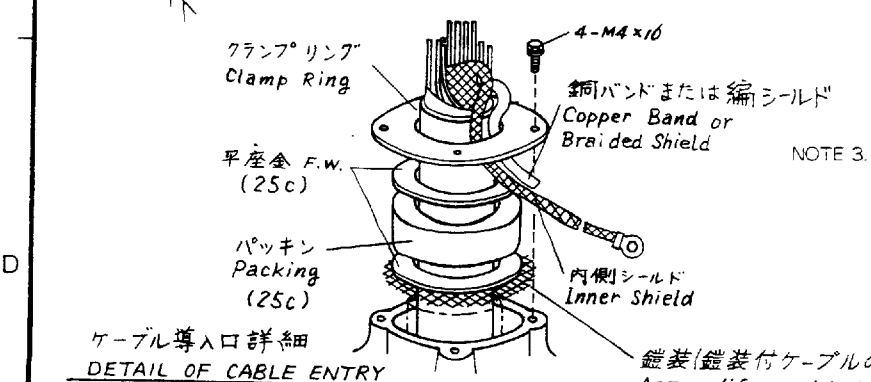
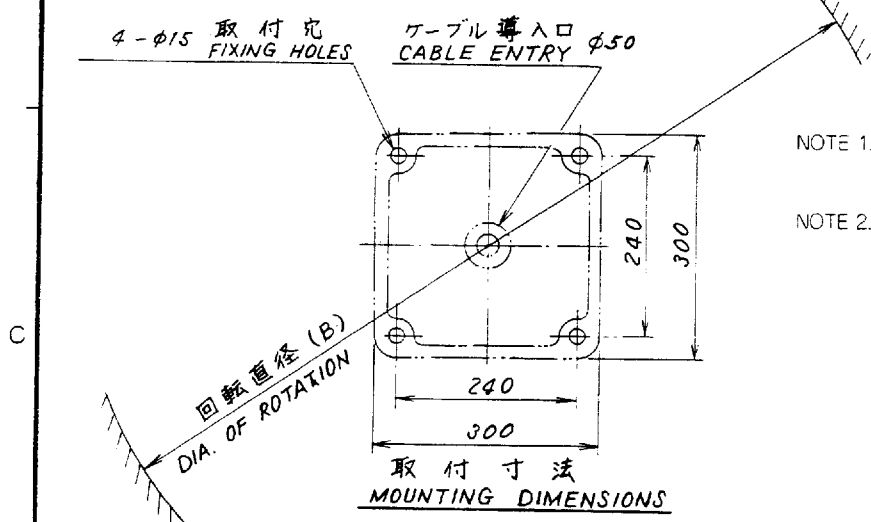
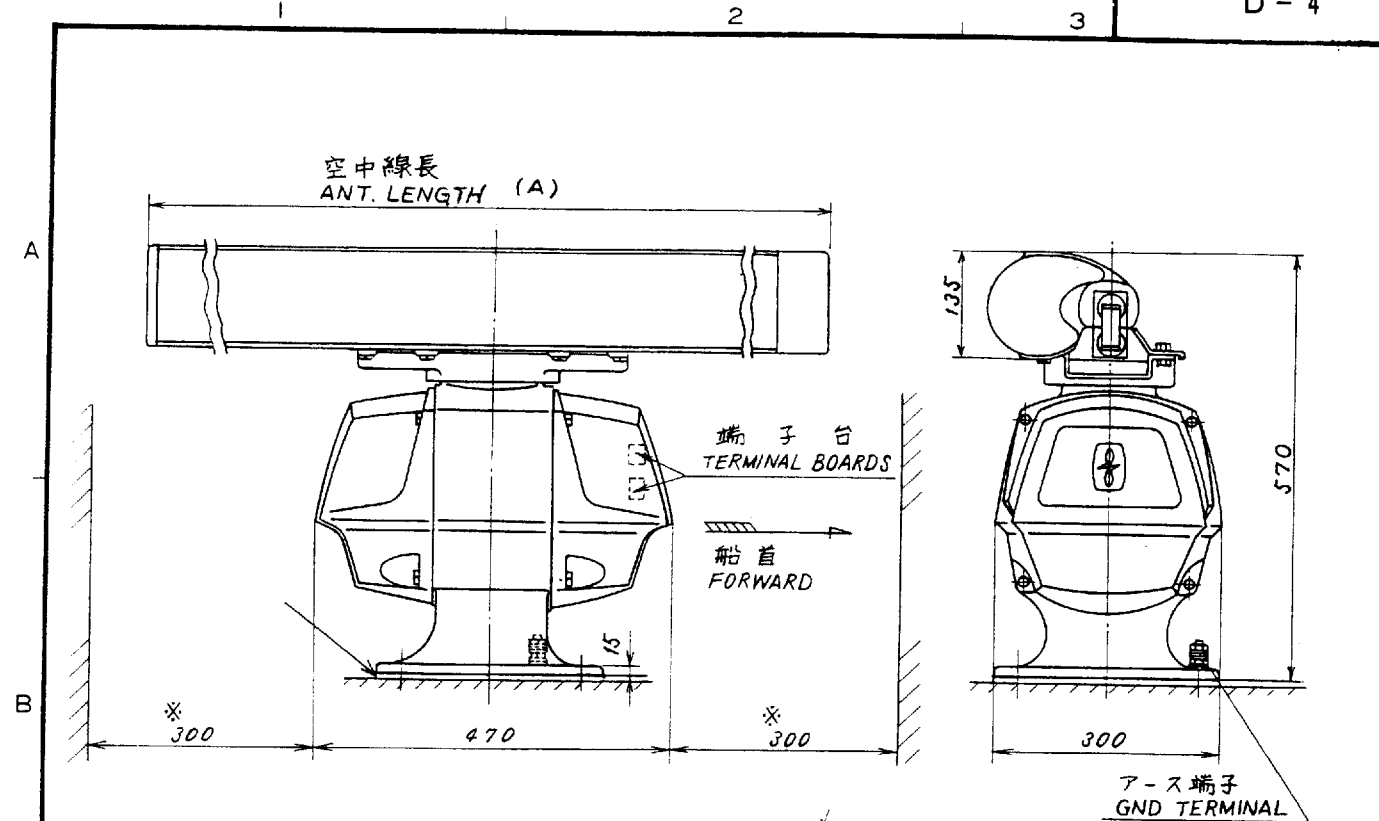

NOTE 1. ※: 推奨サービス空間  
RECOMMENDED SERVICING CLEARANCE

NOTE 2.

種類※※ ANT. TYPE	200cm 型 TYPE (XN-3A)	240cm 型 TYPE (XN-4A)
空中線長 ANT. LENGTH (A)	2070mm	2570mm
回転直径 DIA. OF ROTATION (B)	2200mm	2700mm
質量 MASS	36.5 kg	38.5kg

※※選択可能な空中線部種類はレーダー型式により異なる。各仕様を参照のこと。  
SELECTABLE ANTENNA TYPE DEPENDS ON RADAR MODEL. SEE INDIVIDUAL SPECIFICATIONS.

NOTE 3. 取付台の平面度は±1mm以内のこと。  
THE SURFACE OF PLATFORM SHOULD BE EVEN WITHIN ±1mm.

REMARKS XN3A/4A		TYPE RSB0063/C2P7N2N/C2P8N2N	
DRAWN K.M		名称 空中線部	
APPROVED	FR1510M2 FR2110	NAME RADAR SCANNER UNIT	
SCALE 1/1C	MASS kg	APPLICABLE TO: (MODEL)	BLOCK NO. DWG NO. C3249-011- P

A

B

C

D

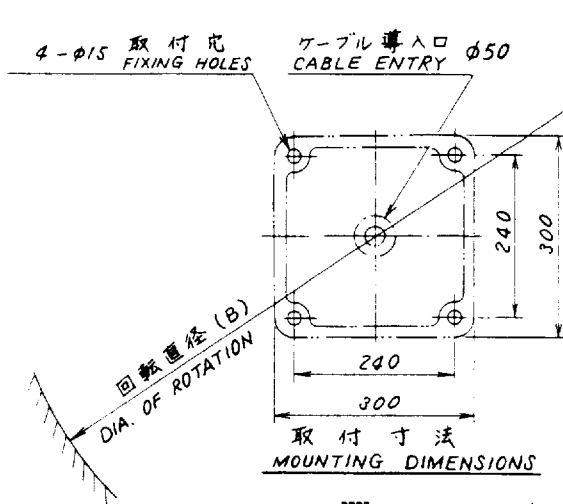
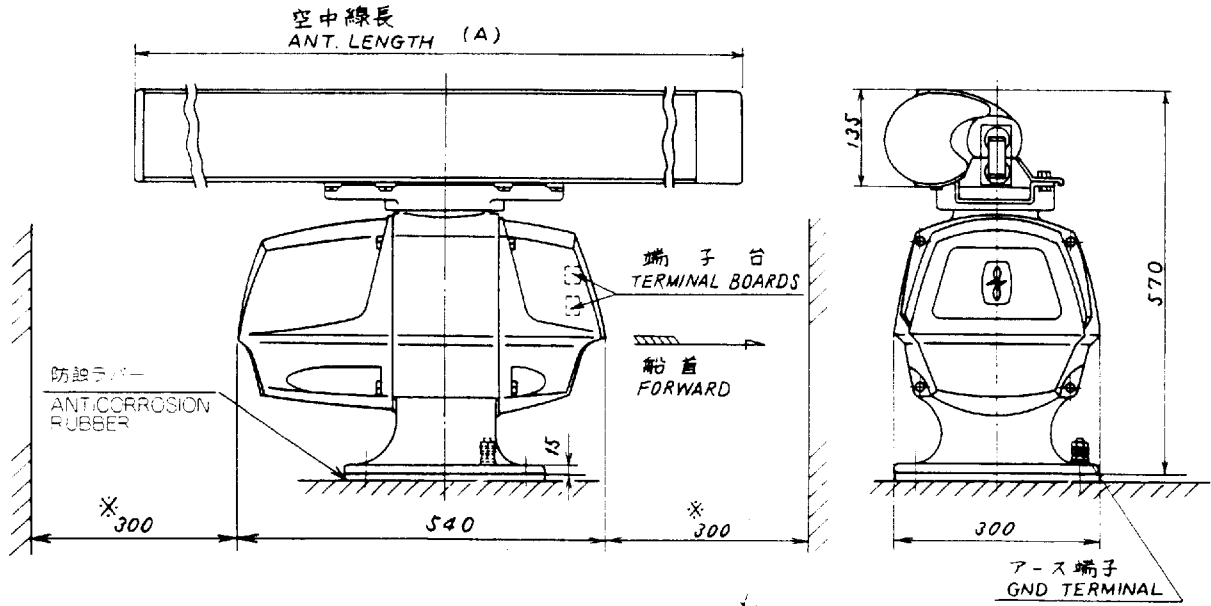

NOTE 1

NOTE 2

推奨サービス空間  
RECOMMENDED SERVICING CLEARANCE

種類** ANT. TYPE	200cm 型 TYPE XN-3A	240cm 型 TYPE XN-4A
空中線長 ANT. LENGTH A	2070mm	2570mm
回転直径 DIA. OF ROTATION (B)	2200mm	2700mm
質量 MASS	39kg	42kg

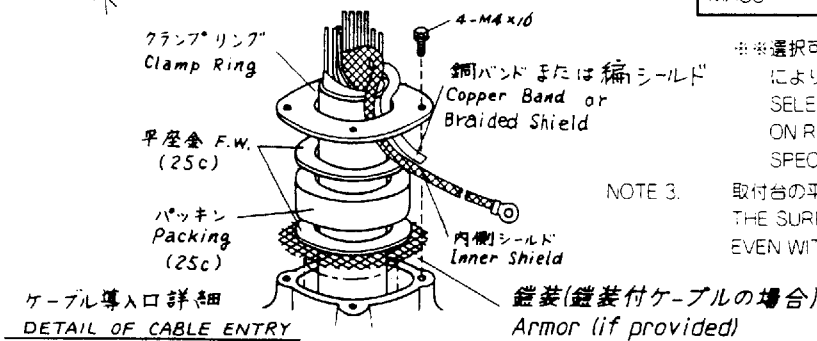

NOTE 3

\*\*選択可能な空中線部種類はレーダー型式により異なる。各仕様を参照のこと。  
SELECTABLE ANTENNA TYPE DEPENDS ON RADAR MODEL. SEE INDIVIDUAL SPECIFICATIONS.

取付台の平面度は±1mm以内のこと。  
THE SURFACE OF PLATFORM SHOULD BE EVEN WITHIN ±1mm.

REMARKS XN3A/4A				TYPE RSB0014/RSB0064
DRAWN K.M	APPROVED KEP	FR1525M2 FR2120		名称 空中線部
SCALE 1/10	MASS kg	APPLICABLE TO: (MODEL)	BLOCK NO.	NAME RADAR SCANNER UNIT
				DWG NO. C3290-003- J

A

B

C

D

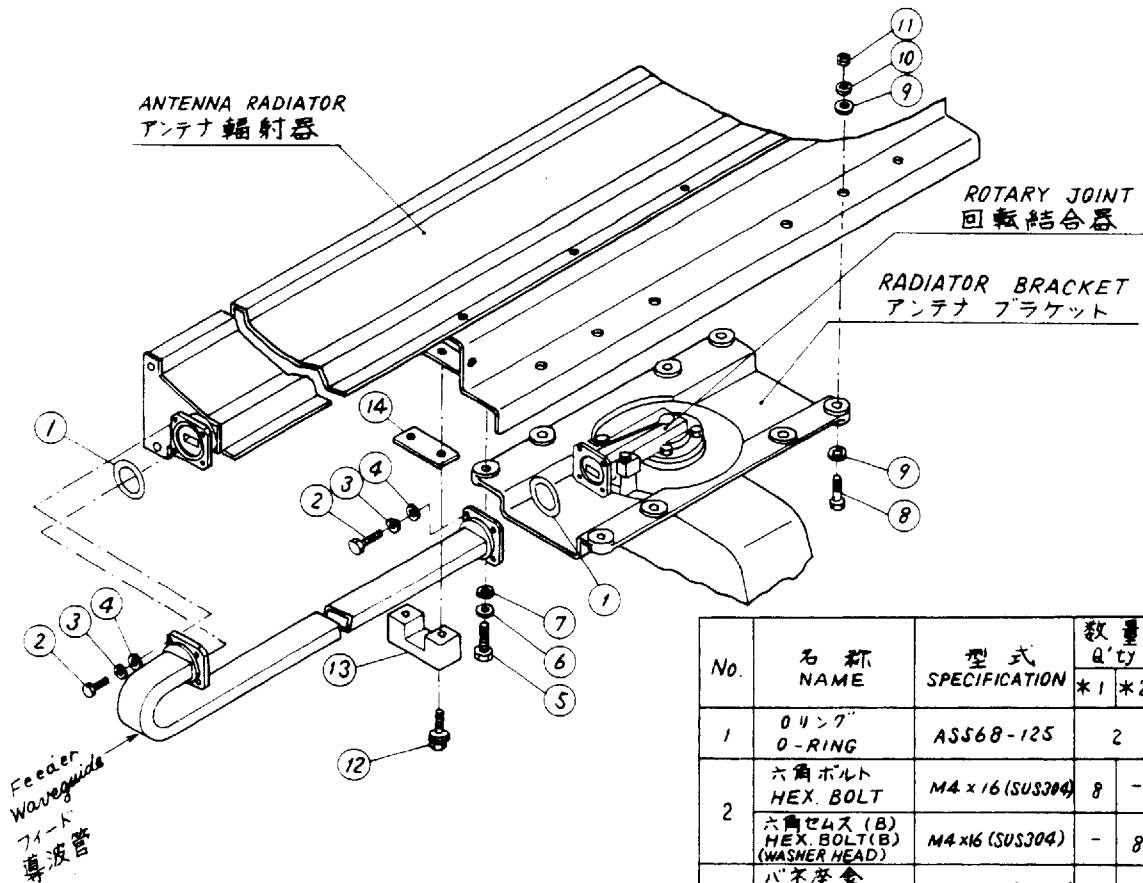

**注意:**

1. 電蝕防止のため、組立時にボルト、ナット、ワッシャ及びフランジ面の Oリング溝外側の部分に支給のシリコンシーラント(無酸性)を塗布する。Oリング及びOリングの溝には塗布しないこと。
2. Oリングに傷をつけたり、ゴミを付着させないように注意のこと。
3. Oリング及びスキャナカバーのパッキンにはグリースを使用すること。シリコンシーラントは使用不可。

**NOTE:**

1. APPLY SILICONE SEALANT (SUPPLIED, NON-ACID TYPE) ON BOLTS, NUTS, WASHER AND WAVEGUIDE FLANGE OUTSIDE O-RING GROOVE TO AVOID ELECTRICAL CORROSION. (DO NOT APPLY SEALANT TO O-RINGS AND O-RING GROOVES.)
2. DO NOT PINCH O-RING AND KEEP IT CLEAN.
3. FOR PACKINGS OF SCANNER COVERS AND O-RINGS, DO NOT USE SILICONE SEALANT, BUT RATHER USE GREASE.

No.	名称 NAME	型式 SPECIFICATION	数量 Q'ty	
			*1	*2
1	Oリング O-RING	ASS68-125	2	
2	六角ボルト HEX. BOLT	M4 x 16 (SUS304)	8	-
	六角ゼムス(B) HEX. BOLT(B) (WASHER HEAD)	M4 x 16 (SUS304)	-	8
3	バネ座金 SPRING WASHER	FOR M4用(SUS304)	8	-
4	平座金 FLAT WASHER	FOR M4用(SUS304)	8	-
5	六角ボルト HEX. BOLT	M8 x 25 (SUS304)	4	-
	六角ゼムス(A) HEX. BOLT(A) (WASHER HEAD)	M6 x 25	-	6
6	バネ座金 SPRING WASHER	FOR M8用(SUS304)	4	-
7	平座金 FLAT WASHER	FOR M8用(SUS304)	4	-
		RSG-1002-0	-	6
8	六角ボルト HEX. BOLT	M8 x 30 (SUS304)	4	6
9	平座金 FLAT WASHER	FOR M8用(SUS304)	8	12
10	バネ座金 SPRING WASHER	FOR M8用(SUS304)	4	6
11	六角ナット HEX. NUT	M8 (SUS304)	4	6
12	六角ゼムス(B) HEX. BOLT(B) (WASHER HEAD)	M4 x 25	-	2
13	導波管押え W/G CLAMP	RSB-2006-1	-	1
14	導波管パッキン W/G PACKING	RSB-2008-0	-	1

\*1: 900/1230mm アンテナ用 (XN-1/2)  
FOR 900/1230mm. RADIATOR (XN-1/2)

\*2: 2000mm アンテナ (XN-3) 用  
FOR 2000mm RADIATOR (XN-3)

品番 ITEM	品名 NAME	材質 MATERIAL	数量 Q'TY	図番 DWG. NO.	摘要 REMARKS
------------	------------	----------------	------------	----------------	---------------

承認  
APPROVED

三角法  
THIRD ANGLE PROJECTION

名称  
TITLE  
**空中線部組立図**  
**SCANNER UNIT ASSEMBLING**  
空中線長 ANT. LENGTH: 900, 1230 & 2000mm (XN-1/2/3)

検図  
CHECKED

尺度  
SCALE

製図  
DRAWN

重量  
WEIGHT kg

図番  
DWG. NO. C3237-025-J

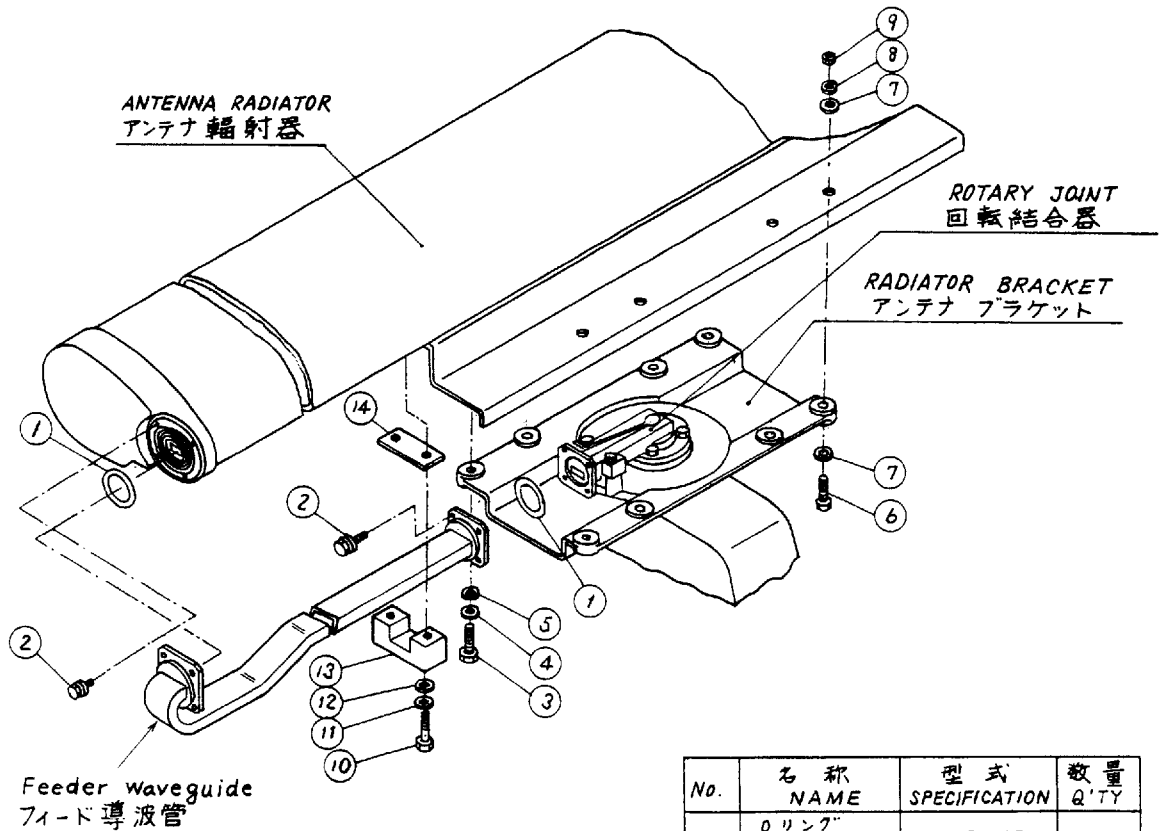

No.	名称 NAME	型式 SPECIFICATION	数量 Q'TY
1	Oリング O-RING	ASS68-125	2
2	六角セムス(B) HEX. BOLT(B) (WASHER HEAD)	M4x16 (SUS304)	8
3	六角ボルト HEX. BOLT	M8x35 (SUS304)	4
4	バネ座金 SPRING WASHER	FOR M8用 (SUS304)	4
5	平座金 FLAT WASHER	FOR M8用 (SUS304)	4
6	六角ボルト HEX. BOLT	M8x30 (SUS304)	4
7	平座金 FLAT WASHER	FOR M8用 (SUS304)	8
8	バネ座金 SPRING WASHER	FOR M8用 (SUS304)	4
9	六角ナット HEX. NUT	M8 (SUS304)	4
10	六角ボルト HEX. BOLT	M4x30 (SUS304)	2
11	バネ座金 SPRING WASHER	FOR M4用 (SUS304)	2
12	平座金 FLAT WASHER	FOR M4用 (SUS304)	2
13	導波管押え W/G CLAMP	RSB-2006-1	1
14	導波管間座 W/G PACKING	03-003-4003-0	1

注意:

1. 電蝕防止のため、組立時にボルト、ナット、ワッシャ及びフランジ面のOリング溝外側の部分に支給のシリコンシーラント(無酸性)を塗布する。Oリング及びOリングの溝には塗布しないこと。
2. Oリングに傷をつけたり、ゴミを付着させないように注意のこと。
3. Oリング及びスキャナカバーのパッキンにはグリースを使用すること。シリコンシーラントは使用不可。

NOTE:

1. APPLY SILICONE SEALANT (SUPPLIED, NON-ACID TYPE) ON BOLTS, NUTS, WASHER AND WAVEGUIDE FLANGE OUTSIDE O-RING GROOVE TO AVOID ELECTRICAL CORROSION. (DO NOT APPLY SEALANT TO O-RINGS AND O-RING GROOVES.)
2. DO NOT PINCH O-RING AND KEEP IT CLEAN.
3. FOR PACKINGS OF SCANNER COVERS AND O-RINGS, DO NOT USE SILICONE SEALANT, BUT RATHER USE GREASE.

品番 ITEM	品名 NAME	材質 MATERIAL	数量 Q'TY	図番 DWG. NO.	摘要 REMARKS
承認 APPROVED	MAY. 25. '79	三角法 THIRD ANGLE PROJECTION  名称 TITLE 空中線部組立図 SCANNER UNIT ASSEMBLING (XN3A/XN4A)  重量 WEIGHT kg 図番 DWG. NO. C3249-017-H			
検図 CHECKED	MAY. 25. '79				
製図 DRAWN	25. 5. 79 H. Kusuda				





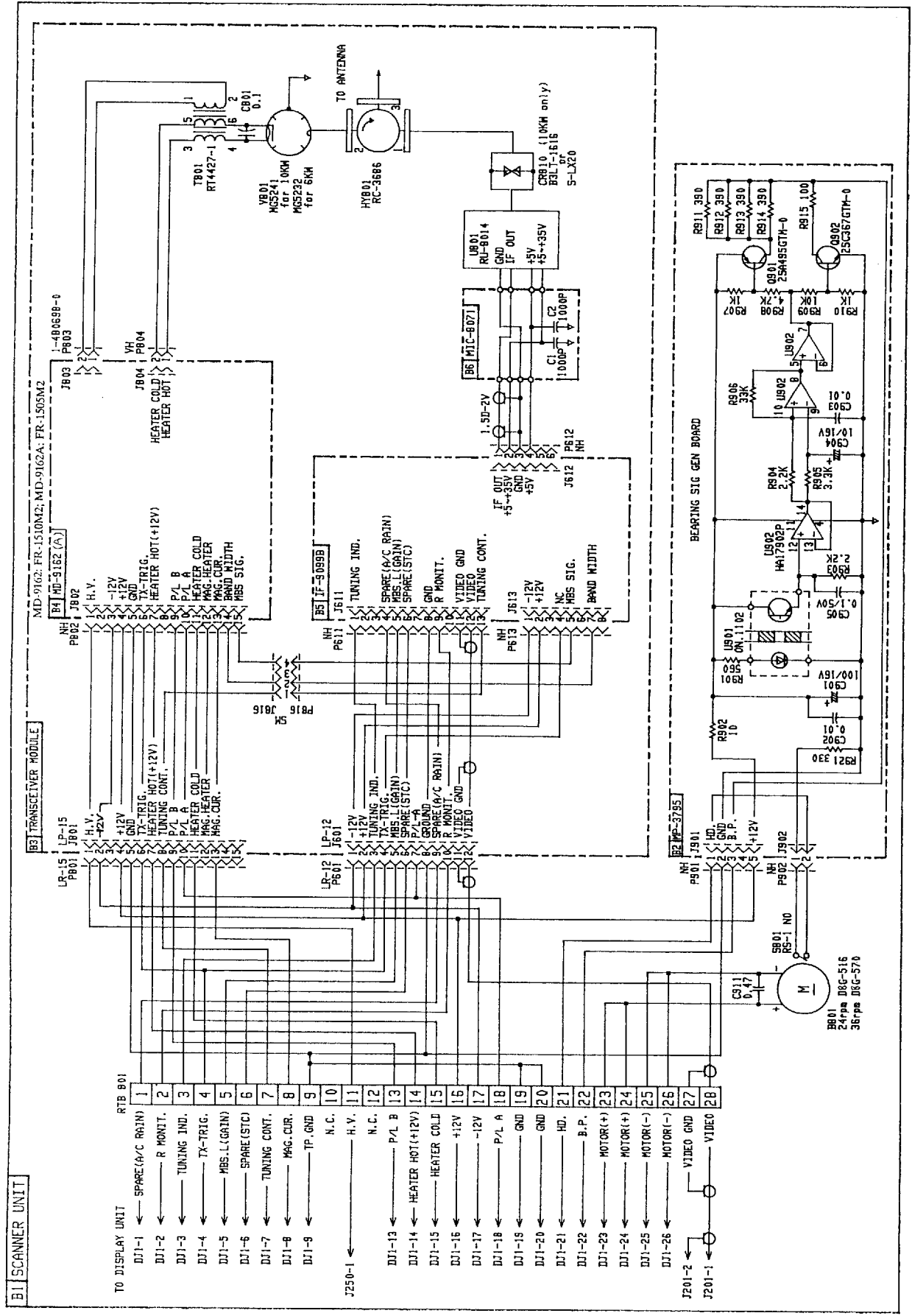

DRAWN	Nov. 1 '75 E. KISHIMA	TYPE	C2P2N2N(24RPM)/RSB-0063(36RPM)
CHECKED	Nov. 1 '75 T. SAITO	名称	空中撮部
APPROVED	Nov. 1 '75 E. UTAHARA	FR-8111	2B 1
SCALE	1/25 (MODEL)	FR1510M2	2B 1
DMG NO.	33308-K01-C	FR1505M2	BLOCK NO.
		APPLICABLE TO:	NAME
			SCANNER UNIT

4

3

2

1

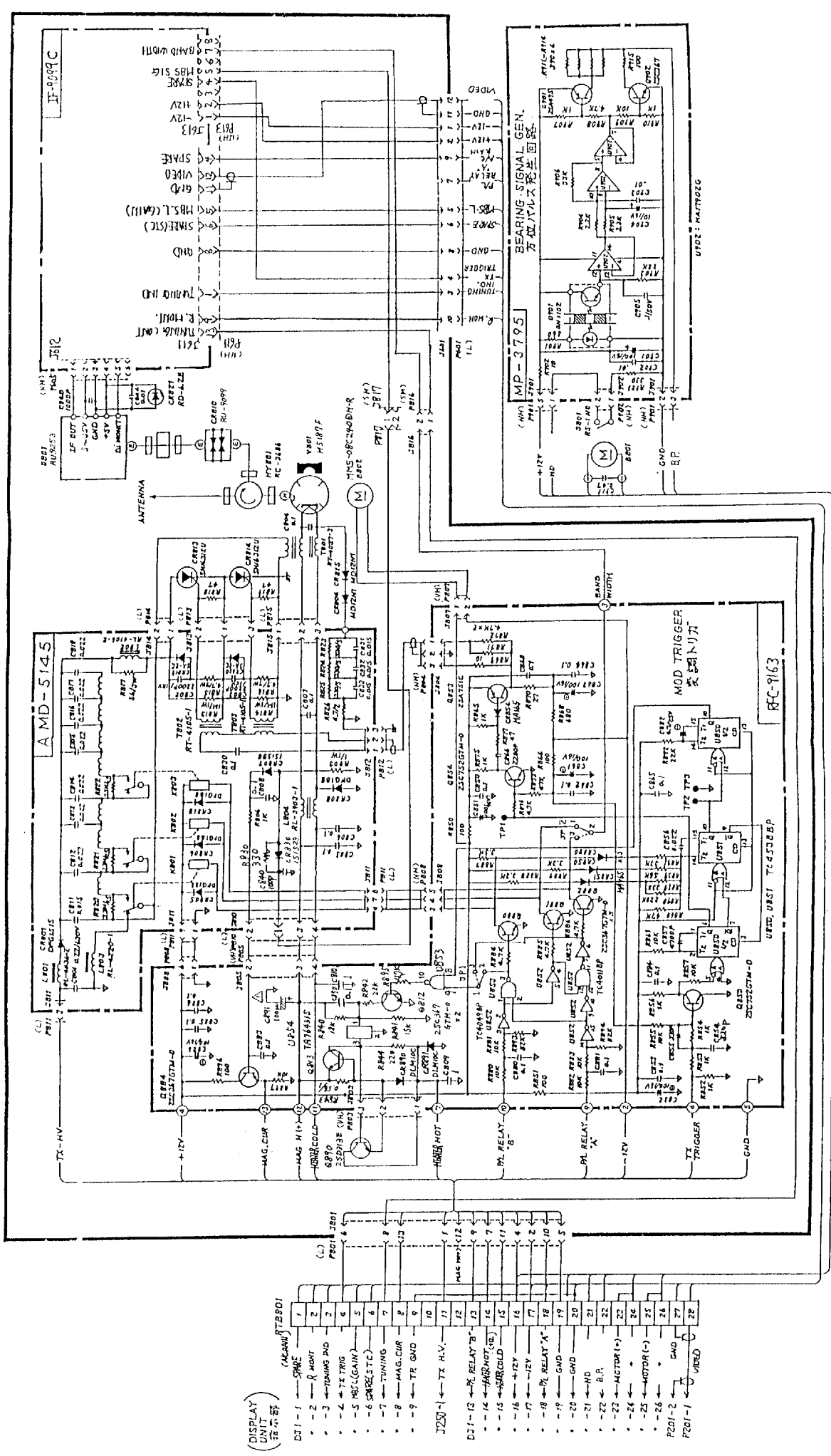

(DISPLAY UNIT 25 26 27)

- 1 ← SPARE
- 2 ← 8 MAG. CUR
- 3 ← TUNING IND
- 4 ← TX TRIG
- 5 ← HORN (GAIN)
- 6 ← HORN (GAIN)
- 7 ← MAG. CUR
- 8 ← TR GND
- 9 ← TX H.V.
- 10 ← TX H.V.
- 11 ← TX H.V.
- 12 ← PA RELAY "B"
- 13 ← PA RELAY "A"
- 14 ← HORN (GAIN)
- 15 ← HORN (GAIN)
- 16 ← +12V
- 17 ← +12V
- 18 ← PA RELAY "A"
- 19 ← GND
- 20 ← GND
- 21 ← HD
- 22 ← B.R.
- 23 ← MOTOR (+)
- 24 ← MOTOR (-)
- 25 ← MOTOR (-)
- 26 ← GND
- 27 ← GND
- 28 ← GND
- 29 ← VIDEO

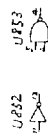

DRAWN	APPROVED	TYPE	RSB0014 (24RPM) / RSB-0064 (36RPM)
Checked by E. KISHIMOTO	Checked by T. SAITO	名称	空中探部
Approved by J. Y.	Approved by K. OTE	回路図	
Scale 1/45	Scale 1/45	BLOCK NO.	2B-1
Weight	Weight	NAME	SCANNER UNIT
Model	Model	APPLICABLE TO:	FR-8251 FR-8252