

# **Class A AIS Transponder**

## **SI-30A Manual Instruction**



## Instruction

**\* The following settings can be modified only the dealer.**

### 1. How to set MMSI IMO & Name, Call sign

#### 1-1 SETTING

MENU key → 2.INIT SETUP → ENT → 2.SET STATIC DATA → ENT → Password → ENT

1-2 Choose setting with arrow keys and then input the data. (After input, press ENT key)

1-2-1 . MMSI : ENT → Input 9 numbers → ENT

1-2-2 . IMO No : Move to IMO No. with arrow keys → ENT → Input IMO ID → ENT

1-2-3 . Ship Name : Move to Ship Name with arrow keys → ENT → Input Name of vessel → ENT

1-2-4 . C. SIGN : Move to C. SIGN with arrow keys → ENT → Input call sign → ENT

#### 1-3 SAVE

1-3-1. After setting press F2(SAVE) → F1(YES : SAVE) / F2(NO : Not save)

1-3-2. F1 is to go back to the previous display without save.

\* MMSI can be modified only in the case of "000000000" and After modifying it is impossible to change. (All static information will be saved in AIS transponder.)

### 2. How to set a location of GPS ANT

#### 2-1 SETTING

MENU key → 2.INIT SETUP → ENT → 5. SET GNSS ANTENNA POSITION → ENT → Password → ENT

2-2 Internal means the internal GPS function, External on the right hand side means a location of GPS antenna.

#### 2-3 How to input

Move to input section with arrow keys → ENT → Input numbers → ENT

#### 2-4 SAVE

2-4-1. After setting press F2(SAVE) → F1(YES : SAVE) / F2(NO : Not save)

2-4-2. F1 is to go back to the previous display without save.

### **3. How to set Port transmission ratio**

#### 3-1 SETTING

MENU key → 3.SYSTEM SETUP → ENT → 1.SET I/O PORT → ENT → Password → ENT

#### 3-2 Definition of Each Port

3-2-1. LONG : Long Range Port(38400/4800)

3-2-2. External Display(38400/4800)

3-2-3. SEN1 : Sensor Port1(38400/4800)

3-2-4. SEN2 : Sensor Port2(38400/4800)

3-2-5. SEN3 : Sensor Port3(38400/4800)

3-2-6. RS232 : RS232 IN / OUT(38400/4800)

#### 3-3 Adjustment for transmission rate of each port

Move to input section with arrow keys → ENT → Arrow key → ENT

#### 3-4 SAVE

3-4-1. After setting press F2 (SAVE) → F1 (YES : SAVE) / F2(NO : Not save)

3-4-2. F1 is to go back to the previous display without save.

### **4. How to change password**

#### 4-1 SETTING

MENU key → 3.SYSTEM SETUP → ENT → 4. SET PASSWORD → ENT → Password → ENT

#### 4-2 How to input (Password shall be 6 numbers)

Move to OLD PASSWORD → ENT → Input Number → ENT → Move to NEW PASSWORD → ENT → Input New password → ENT → Move to CONFIRM NEW PASSWORD → ENT → Input new password → ENT

#### 4-3 SAVE

4-3-1. After setting press F2(SAVE) → F1(YES : SAVE) / F2(NO : Not save)

4-3-2. F1 is to go back to the previous display without save.



## CAUTION

1. Ship's position received through the AIS might be different from the actual ship's position. It is desirable to always check visually with Radar prior to using AIS equipment for navigation data.

For External GPS data, NMEA Version 2.0 or above should be used based on RS-422/RS-232 of IEC-61162 (RS-422).

2. For External GPS data, if it is not connected with the format recommended by IMO, it may disturb the vessel traffic control, finally to create any dangerous accidents such as ship's collision .

3. Be sure to read carefully safety guidelines and indications before operation for this product and related documents.

| MARK  | DESCRIPTION   |
|---|---|
|  | <p>All PCB used in this unit are manufactured according to protection environment for discharging static electricity, because all semiconductor elements used in this PCB could be damaged sensitively due to electrostatic.</p>  |
|  | <p>To prevent the unit from damaging due to electrostatic, operator should seek suitable preventive measure before operating.</p> <p>Handling circuit related working should be carried out by technicians who specialize for the electronic device sensitive.</p> <p>Dismantling SI-30A is restricted to the person who is authorized by Manufacturer.</p> |

-----TABLE OF CONTENTS-----

|   |          |
|---|----------|
| <b>1. AUTOMATIC IDENTIFICATION SYSTEM .....</b>       | <b>1</b> |
| 1-1 AIS OUTLINE .....                                 | 1        |
| 1-2 AIS TECHNICAL OUTLINE .....                       | 1        |
| 1-3 DATA FOR AIS .....                                | 1        |
| 1-4 INTERVAL OF RENEWAL AIS DATA FOR EACH CLASS.....  | 2        |
| <b>2. PRODUCT SPECIFICATION .....</b>                 | <b>4</b> |
| 2-1 DESIGNED TO MEET THE FOLLOWING STANDARDS .....    | 4        |
| 2-2 PRODUCT SPECIFICATION.....                        | 4        |
| 2-3 AIS TRANSMITTER.....                              | 4        |
| 2-4 AIS RECEIVERS .....                               | 5        |
| 2-5 DSC RECEIVERS.....                                | 5        |
| 2-6 SERIAL INPUTS/OUTPUTS.....                        | 5        |
| 2-7 GPS ANTENNA AND RECEIVER .....                    | 5        |
| 2-8 ENVIRONMENT .....                                 | 6        |
| 2-9 COMPOSITION .....                                 | 7        |
| 2-9-1 <i>SI-30A Basic Specification</i> .....         | 7        |
| 2-9-2 <i>SI-30A Optional Specification</i> .....      | 7        |
| <b>3. HOW TO USE SI-30AM(MKD).....</b>                | <b>8</b> |
| 3-1 OPERATION.....                                    | 8        |
| 3-1-1 <i>Button description</i> .....                 | 8        |
| 3-1-2 <i>LED</i> .....                                | 10       |
| 3-1-3 <i>Buzzer</i> .....                             | 10       |
| 3-2 BASIC OPERATION .....                             | 10       |
| 3-2-1 <i>Power ON/OFF</i> .....                       | 10       |
| 3-3 LIST DISPLAY .....                                | 11       |
| 3-3-1 <i>List Display description</i> .....           | 11       |
| 3-3-2 <i>How to set ship's name and MMSI</i> .....    | 12       |
| 3-3-3 <i>Array Objects</i> .....                      | 12       |
| 3-3-4 <i>Message icon</i> .....                       | 13       |
| 3-4 PLOTTER (GRAPHIC) SCREEN .....                    | 14       |
| 3-4-1 <i>Explanation of plotter screen</i> .....      | 14       |
| 3-4-2 <i>Chat direction / Distance settings</i> ..... | 15       |
| 3-4-3 <i>Display of vessel information</i> .....      | 15       |

|        |   |    |
|--------|---|----|
| 3-4-4  | <i>Indication of letter's information</i> ..... | 16 |
| 3-4-5  | <i>Display of Range Ring</i> .....              | 16 |
| 3-4-6  | <i>Display of chart</i> .....                   | 17 |
| 3-4-7  | <i>Transfer of cart</i> .....                   | 17 |
| 3-4-8  | <i>Use of cursor</i> .....                      | 18 |
| 3-4-9  | <i>Changing screen / Data view</i> .....        | 19 |
| 3-5    | OWN SHIP DATA DISPLAY.....                      | 20 |
| 3-6    | COMPOSITION & USAGE OF MENU.....                | 21 |
| 3-6-1  | <i>Composition of menu</i> .....                | 21 |
| 3-7    | MESSAGE SETUP.....                              | 22 |
| 3-7-1  | <i>NEW MESSAGE</i> .....                        | 22 |
| 3-7-2  | <i>FAVORITE MESSAGES</i> .....                  | 23 |
| 3-7-3  | <i>LONG RANGE MESSAGE</i> .....                 | 23 |
| 3-7-4  | <i>RxD MESSAGE</i> .....                        | 24 |
| 3-7-5  | <i>TxD MESSAGE</i> .....                        | 24 |
| 3-7-6  | <i>ALARM MESSAGE</i> .....                      | 25 |
| 3-7-7  | <i>STATUS MESSAGE</i> .....                     | 26 |
| 3-8    | INITIAL SETUP.....                              | 27 |
| 3-8-1  | <i>VOYAGE DATA</i> .....                        | 27 |
| 3-8-2  | <i>STATIC DATA</i> .....                        | 28 |
| 3-8-3  | <i>REGIONAL AREAS</i> .....                     | 28 |
| 3-8-4  | <i>LONG RANGE MODE</i> .....                    | 29 |
| 3-8-5  | <i>GNSS ANTENNA POSITION</i> .....              | 30 |
| 3-9    | SYSTEM SETUP.....                               | 31 |
| 3-9-1  | <i>SET I/O PORT TRANSMIT RATE</i> .....         | 31 |
| 3-9-2  | <i>BRIGHTNESS ADJUSTMENT</i> .....              | 32 |
| 3-9-3  | <i>SET BUZZER</i> .....                         | 32 |
| 3-9-4  | <i>SET PASSWORD</i> .....                       | 33 |
| 3-9-5  | <i>SET ETC</i> .....                            | 33 |
| 3-10   | MAINTENANCE.....                                | 35 |
| 3-10-1 | <i>PROGRAM VERSION</i> .....                    | 35 |
| 3-10-2 | <i>KEY TEST</i> .....                           | 35 |
| 3-10-3 | <i>LCD TEST</i> .....                           | 36 |
| 3-10-4 | <i>COM MONITORING</i> .....                     | 36 |
| 3-10-5 | <i>SECURITY LOG</i> .....                       | 37 |
| 3-10-6 | <i>TRANSPONDER TEST</i> .....                   | 37 |

|           |   |           |
|-----------|---|-----------|
| 3-10-7    | PROGRAM DOWNLOAD.....   | 38        |
| 3-10-8    | PROGRAM UPLOAD.....   | 38        |
| 3-11      | THE EXPLANATION SIGNS OF AIS.....                                     | 39        |
| <b>4.</b> | <b>THE INSTALLATION METHOD AND EXPLANATION EQUIPMENT .....</b>        | <b>40</b> |
| 4-1       | THE EXPLANATION METHOD.....   | 40        |
| 4-1-1     | <i>Front side</i> .....   | 40        |
| 4-1-2     | <i>Back Side</i> .....  | 41        |
| 4-2       | THE METHOD OF INSTALLATION .....                                      | 42        |
| 4-3       | MAIN UNIT INSTALLATION .....  | 42        |
| 4-3-1     | <i>How to setup Antenna</i> .....                                     | 43        |
| 4-3-2     | <i>When you install VHF Antenna, please check bellows</i> .....       | 44        |
| <b>5.</b> | <b>MAINTENANCE AND TROUBLESHOOTING .....</b>                          | <b>45</b> |
| 5-1       | MAINTENANCE AND TROUBLESHOOTING OF SYSTEM.....                        | 45        |
| 5-2       | TROUBLESHOOTING.....  | 45        |
| <b>6.</b> | <b>APPENDIX.....</b>  | <b>46</b> |
| 6-1       | NMEA SENTENCES USED .....   | 46        |
| 6-2       | ALARM MESSAGES .....  | 46        |
| 6-2-1     | <i>Decoded Sentences</i> .....  | 50        |
| 6-2-2     | <i>Position Sensor Priority List</i> .....                            | 50        |
| 6-3       | MESSAGE STRUCTURES.....   | 51        |
| 6-3-1     | <i>ABK - AIS addressed and binary broadcast acknowledgement</i> ..... | 51        |
| 6-3-2     | <i>ABM – AIS addressed binary and safety related message</i> .....    | 51        |
| 6-3-3     | <i>ACA – AIS channel assignment message</i> .....                     | 51        |
| 6-3-4     | <i>ACK – Acknowledge alarm</i> .....                                  | 52        |
| 6-3-5     | <i>ACS - AIS channel management information source</i> .....          | 52        |
| 6-3-6     | <i>AIR – AIS interrogation request</i> .....                          | 52        |
| 6-3-7     | <i>ALR – Alarm condition and status</i> .....                         | 53        |
| 6-3-8     | <i>BBM - AIS broadcast binary message</i> .....                       | 53        |
| 6-3-9     | <i>DTM – Datum reference</i> .....                                    | 53        |
| 6-3-10    | <i>GBS – GNS satellite fault detection</i> .....                      | 54        |
| 6-3-11    | <i>GGA – Global positioning system (GPS) fix data</i> .....           | 54        |
| 6-3-12    | <i>GLL – geographic position</i> .....                                | 54        |
| 6-3-13    | <i>GNS – GNSS fix data</i> .....                                      | 55        |
| 6-3-14    | <i>HDT – heading true</i> .....                                       | 55        |

|        |   |    |
|--------|---|----|
| 6-3-15 | <i>LR1 - AIS long-range reply 1</i> .....                 | 55 |
| 6-3-16 | <i>LR2 - AIS long-range reply 2</i> .....                 | 55 |
| 6-3-17 | <i>LR3 - AIS long-range reply 3</i> .....                 | 56 |
| 6-3-18 | <i>LRF - AIS long-range function</i> .....                | 56 |
| 6-3-19 | <i>LRI - AIS long-range interrogation</i> .....           | 56 |
| 6-3-20 | <i>OSD – Own ship data</i> .....                          | 57 |
| 6-3-21 | <i>RMC – recommended minimum specific GNSS data</i> ..... | 57 |
| 6-3-22 | <i>ROT – rate of turn</i> .....                           | 58 |
| 6-3-23 | <i>SSD – Ship Static Data</i> .....                       | 58 |
| 6-3-24 | <i>THS – True heading and status</i> .....                | 58 |
| 6-3-25 | <i>TXT – text transmission</i> .....                      | 59 |
| 6-3-26 | <i>VBW – Dual ground/water speed</i> .....                | 59 |
| 6-3-27 | <i>VDM – VHF data link message</i> .....                  | 59 |
| 6-3-28 | <i>VDO - AIS VHF Data-link own-vessel report</i> .....    | 59 |
| 6-3-29 | <i>VSD – AIS voyage static data</i> .....                 | 60 |
| 6-3-30 | <i>VTG – course over ground and ground speed</i> .....    | 60 |
| 6-4    | ABBREVIATIONS .....                                       | 61 |
| 6-5    | PACKING LIST .....  | 63 |
| 6-6    | DRAWINGS .....  | 65 |
| 6-6-1  | <i>External Connection</i> .....                          | 65 |
| 6-6-2  | <i>Port Connection</i> .....                              | 66 |
| 6-6-3  | <i>SI-30A OUTLINE DRAWING</i> .....                       | 67 |
| 6-6-4  | <i>SI-30AM OUTLINE DRAWING</i> .....                      | 68 |
| 6-6-5  | <i>SAN-150 ANTENNA OUTLINE DRAWING</i> .....              | 69 |
| 6-6-6  | <i>SAN-60 ANTENNA OUTLINE DRAWING</i> .....               | 70 |



## 1. Automatic Identification System

### 1-1 AIS OUTLINE

AIS is a very developed equipment which provides information of the vessel in real time.

This equipment is prevent for collision and this is duty by IMO. AIS make you enable to recognize position of another vessel and it's moving during radar isn't working properly, to recognize name, position and speed of another vessel so that it prevents for collision.

AIS is using VHF frequency, 161.975MHz(87B channel) and 162.025MHz(88B channel) which are assigned by World wireless association in 1997.

### 1-2 AIS Technical Outline

- ◆ AIS is basis on TDMA and simplex, semi-duplex or duplex communication and occupied bandwidth is within 25kHz.

### 1-3 Data for AIS

- ◆ **Static Information** : IMO number, Call sign and Name of vessel, length and beam, ship's type, the position and antenna on a ship. Data is renewed every 6 minutes or when it needs to be amended.
- ◆ **Dynamic Information** : Accurate command and ship's position in perfect condition, Time(UTC), course over ground(COG), speed of ground(SOG), Heading, Navigation status, ratio of turn.
- ◆ **Voyage Information** : Draught, Dangerous cargo, Destination and ETA, Route plan, number of crew. Data is renewed every 6 minutes or when it needs to be amended.
- ◆ **Safety Message** : You shall follow needs of message and this includes voyage information and weather alarm.

### 1-4 Interval of renewal AIS data for each class

| Status of vessel(A Class)                                   | Interval |
|---|----------|
| Under 3knot during anchorage or mooring                     | 3 min    |
| Over 3knot during anchorage or mooring                      | 10 sec   |
| Sailing under at 14knot                                     | 10 sec   |
| Changing course during sailing under 14knot                 | 3½ sec   |
| Sailing at between 14knot and 23knot                        | 6 sec    |
| Changing course during sailing at between 14knot and 23knot | 2 sec    |
| Sailing over at 23knot                                      | 2 sec    |
| Changing course during sailing over at 23knot               | 2 sec    |

| Status of vessel(B Class) | Interval |
|---------------------------|----------|
| Sailing under 2knot       | 3 min    |
| Sailing over 2knot        | 30 sec   |

| DATA                                       | A Class | B Class |
|--|---------|---------|
| <b>Static Information of Radio Station</b> |         |         |
| - MMSI                                     | ▼       | ▼       |
| - Ship's Name                              | ▼       | ▼       |
| - Ship's type                              | ▼       | ▼       |
| - Call sign                                | ▼       | ▼       |
| - IMO number                               | ▼       |         |
| - Position of Antenna                      | ▼       | ▼       |
| - Length and beam                          | ▼       | ▼       |
| <b>Voyage Information</b>                  |         |         |
| - Draught                                  | ▼       |         |
| - Number of crew                           | ▼       |         |
| - Dangerous Cargo                          | ▼       |         |
| - Destination and ETA                      | ▼       |         |

| <b>Dynamic Information</b>        |   |   |
|-----------------------------------|---|---|
| - Universal Time Coordinated(UTC) | ▼ | ▼ |
| - Ship's position                 | ▼ | ▼ |
| - Course over Ground (COG)        | ▼ | ▼ |
| - Speed of Ground (SOG)           | ▼ | ▼ |
| - Heading                         | ▼ | ▼ |
| - Ratio of turn                   | ▼ |   |
| - Navigation Status               | ▼ |   |
| - Ship's condition                | ▼ |   |
| <b>Message</b>                    |   |   |
| - Alarm                           | ▼ |   |
| - Safety                          | ▼ | ▼ |

When you input the static information for radio station, please download the software from 'product information' of web page (<http://www.samyungenc.com>) and then you can install into your Computer.

It is also available for MKD.

## **2. PRODUCT SPECIFICATION**

### **2-1 Designed to meet the following standards**

- ◆ IEC61993-2 ..... IEC standard, Class A shipborne equipment
- ◆ IEC60945 Edn 4.0 ..... IEC standard, environmental requirements
- ◆ ITU-RM.1371-4 ..... Universal AIS Technical Characteristics
- ◆ IEC61162-1/2 Edn. 2.0 ..... IEC standards, digital interfaces
- ◆ IEC61108-1 ..... IEC standard, GPS receiver equipment

### **2-2 PRODUCT SPECIFICATION**

- ◆ Power Consumption ..... 50W peak / 10W average
- ◆ Power supply ..... 12V DC -10% +30%(DC10.8V~15.6V)
- ◆ Power supply (SP-580AD) ..... 24V DC -10% +30% / 110V AC / 220V AC  
OUT 13.8V
- ◆ Default Frequencies ..... AIS1 (CH 87B) : 161.975 MHz(F1D)  
AIS2 (CH 88B) : 162.025 MHz(F1D)  
DSC (CH70) : 156.525 MHz(G2B)
- ◆ Frequency range ..... 156.025 ~ 162.025 MHz
- ◆ Transponder size/weight ..... 221 x 165 x 95 mm, 1.5 kg
- ◆ MKD size/weight ..... 255 x 162 x 75 mm, 0.9 kg
- ◆ GPS size/weight ..... 90 x Ø65mm (+140mm mounting bar) 0.2kg
- ◆ Compass safe Distance ..... Display : 0.7 m for 1° / 1.2 m for 0.3° deviation  
Transponder : 1.3 m for 1° / 2.1 m for 0.3° deviation
- ◆ Indicators(LED) ..... POWER, TX, RX, Status, Error

### **2-3 AIS Transmitter**

- ◆ Power output ..... 12.5W or 1.0W(41dBm ±1.5 dB or 30dBm ±1.5 dB)
- ◆ Antenna impedance ..... 50 ohms(SO-239)
- ◆ Channel spacing ..... 25kHz
- ◆ Frequency error ..... <±0.5 kHz
- ◆ Spurious emissions ..... <-36dBm at 9KHz ~ 1GHz  
<-30dBm at 1GHz ~ 4GHz

## 2-4 AIS Receivers

- ◆ Sensitivity ..... (PER) < 20% at -107 dBm
- ◆ Channel spacing ..... 25 kHz
- ◆ Modulation..... GMSK
- ◆ Data rate..... 9600 bits/s
- ◆ Frequency stability..... <±1 ppm
- ◆ Co-Channel ..... 10dB
- ◆ Adjacent Channel..... 70dB
- ◆ IMD ..... 65dB
- ◆ Blocking ..... 84dB

## 2-5 DSC Receivers

- ◆ Sensitivity ..... BER <10<sup>-4</sup> at 107 dBm
- ◆ Channel spacing ..... 25 kHz
- ◆ Modulation..... FSK (1300 Hz/2100 Hz)
- ◆ Frequency stability..... <±1 ppm
- ◆ Co-Channel ..... 10dB
- ◆ Adjacent Channel..... 70dB
- ◆ IMD ..... 65dB
- ◆ Blocking ..... 84dB

## 2-6 Serial inputs/outputs

- ◆ SENS1/2/3/4 ..... IEC61162-1/2 (input only)
- ◆ LONG/AUX/PILOT/RTCM ..... IEC61162-1/2 (input & output)
- ◆ Display ..... RS422 non-isolated

## 2-7 GPS Antenna and Receiver

- ◆ Antenna..... PATCH ANTENNA / TNC (RG-58U)
- ◆ Receiver Type ..... 16channel, L1 frequency, C/A code
- ◆ Accuracy ..... Position 2.5 m CEP / DGPS ,SBAS 2.0 m CEP
- ◆ Start-up Times ..... Hot start <3.5sec / Warm start 33sec / Cold start 34sec / Aided start 5 sec / Reacquisition < 1 s
- ◆ Sensitivity ..... Acquisition -140 dBm / Tracking -150 dBm

## 2-8 Environment

- ◆ Operation temperature ..... -15°C to +55°C
- ◆ Storage temperature..... -25°C to +75°C
- ◆ Relative humidity..... 95% at 40°C (without dew condensation)
- ◆ Vibration..... IEC 60945

## 2-9 Composition

### 2-9-1 SI-30A Basic Specification

| No. | Item               | Standard             | Quantity | Remark      |
|-----|--------------------|----------------------|----------|-------------|
| 1-1 | Transponder        | SI-30A               | 1EA      | E02-3000-00 |
| 1-2 | Equip. for install | SI-30A-A-K           | 1SET     |             |
| 2-1 | MKD                | SI-30AM              | 1EA      | E02-4000-01 |
| 3-1 | VHF Antenna        | SAN-150              | 1EA      | 542-1400-0D |
| 3-2 | Bracket            | Bracket 35 Ass'y     | 1SET     | 575-0006-01 |
| 3-3 | Cable Ass'y        | PL259-30M(RG8)-PL259 | 1SET     | 574-0155-24 |
| 4-1 | GPS Antenna        | SAN60-30M(RG58)-TNC  | 1SET     | 574-9999-02 |
| 5-1 | Power              | SP-700               | 1EA      | V01-0000-00 |
| 5-2 | Equip. for install | SP-700-A             | 1SET     |             |
| 6-1 | Instruction        | SI-30A-ME            | 1EA      | M03-0101-00 |

### 2-9-2 SI-30A Optional Specification

| No. | Description    | Standard | Quantity | Remark |
|-----|----------------|----------|----------|--------|
| 1   | GYRO CONVERTER | SAD-30DC | 1EA      |        |

### 3. How to use SI-30AM(MKD)

- DC 12V











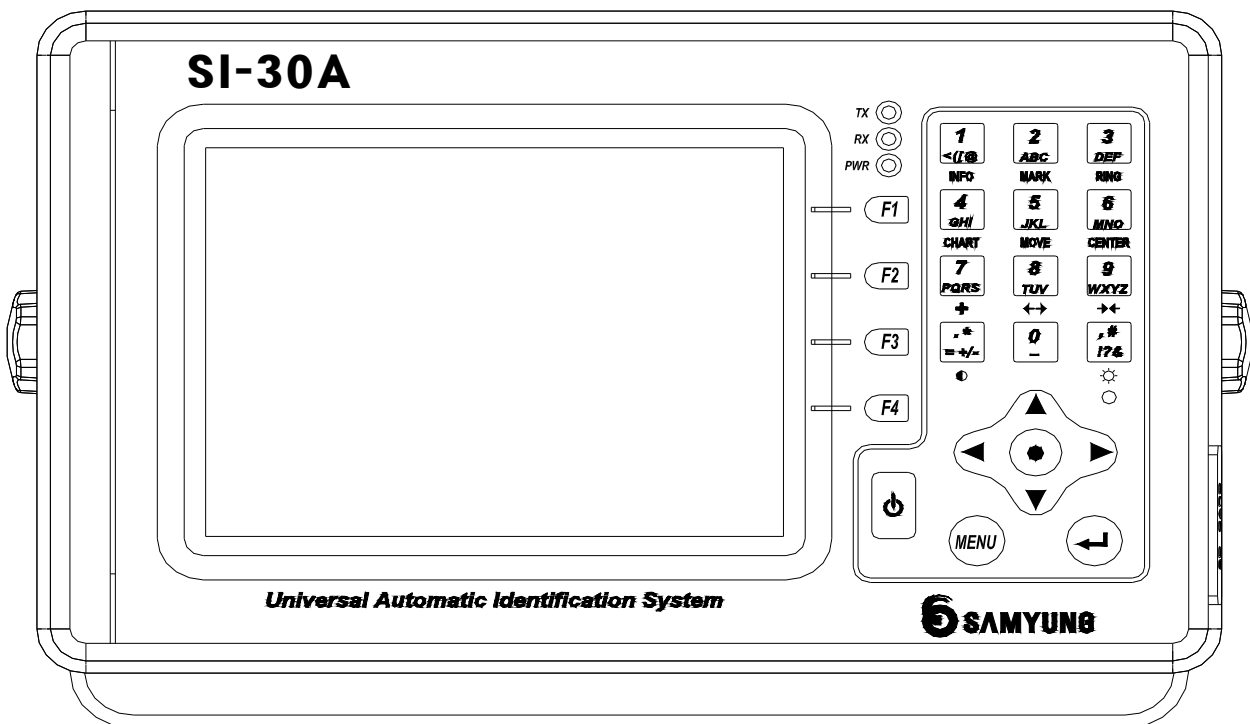











(Warning) A version of programme could be adjusted without notice.

#### 3-1 Operation

##### 3-1-1 Button description

It shows alphanumeric and symbol input buttons. To input alphabet and various buttons, press the assigned button until the wanted button is displayed.



- |    |  |   |
|----|--|---|
| 1  |   | To display information of the vessel what you choose.   |
| 2  |   | To display of geographical name & Depth.  |
| 3  |   | To display range of ring.   |
| 4  |   | To display map.   |
| 5  |   | To move map moving or to choose another vessel.   |
| 6  |   | To check vessel's position or to make cursor in the centre of display.  |
| 7  |   | To move cursor.   |
| 8  |   | To enlarge map.   |
| 9  |    | To reduce map.  |
| 10 |   | To be dark.(10level)  |
| 11 |   | To be bright.(10level)  |
| 12 |   | To change letter style and colour of display on the list menu.  |
| 13 |   | <b>Arrow key:</b> Buttons for moving to up/down/right/left side and for movement of cursor and for deletion of previously input data. |
| 14 |   | <b>Power key:</b> To use for power off and on. If press a short time, power is on and if press a longer time, power is off.           |
| 15 |   | <b>Menu key:</b> It is displayed related to Menu, goes back to menu mode if press it in any mode.                                     |
| 16 |   | <b>Enter Key:</b> It makes it possible to store the information after alteration or correction of them.                               |
| 17 | <br><br><br> | They are 4 function keys indicating LCD of MKD, which makes it possible to implement the function of the pressed button.              |

### 3-1-2 LED

There are 3 different LEDs depends on each function. TX LED in upper, RX LED in middle and POWER LED at bottom.

Each function is as follows.

| LED | Function  | Remark     |
|-----|---|------------|
| TX  | This function is to indicate when MKD display transmits data to transponder.  | RED LED    |
| RX  | This function is to indicate when MKD display receives data from transponder. | ORANGE LED |
| PWR | This function is to indicate when MKD display is being powered on.            | YELLOW LED |

### 3-1-3 Buzzer

Buzzer function in MKD display gives "BEEP" signal from buzzer whenever each button in MKD display is pressed, which enables user to operate the unit efficiently. It is also designed to detect the alarm when it is activated as it gives alarm function to buzzer.

## 3-2 Basic Operation

### 3-2-1 Power ON/OFF

The unit will be operational within 2 minutes of switching on and transmit own ship's static data. These data are retransmitted every 6 minutes or when data has been changed and on request. The static data provided by AIS includes IMO number, MMSI number, Call sign, Length and width, Type of ship and Position of GPS antenna. Safety related information should be reported on request.

SI-30A should be power on while navigation or at anchor. However, ship's master may decide power off when he judged that ship's safety and security might be threatened due to constant operation of AIS. SI-30A should be restarted when the cause of danger will be safely eliminated.

After transponder and MKD powered on, SI-30A starts receiving data from other ships and displays object data on LCD of MKD.

### 3-3 List Display

#### 3-3-1 List Display description

Home screen is displayed as below and each section means as following.

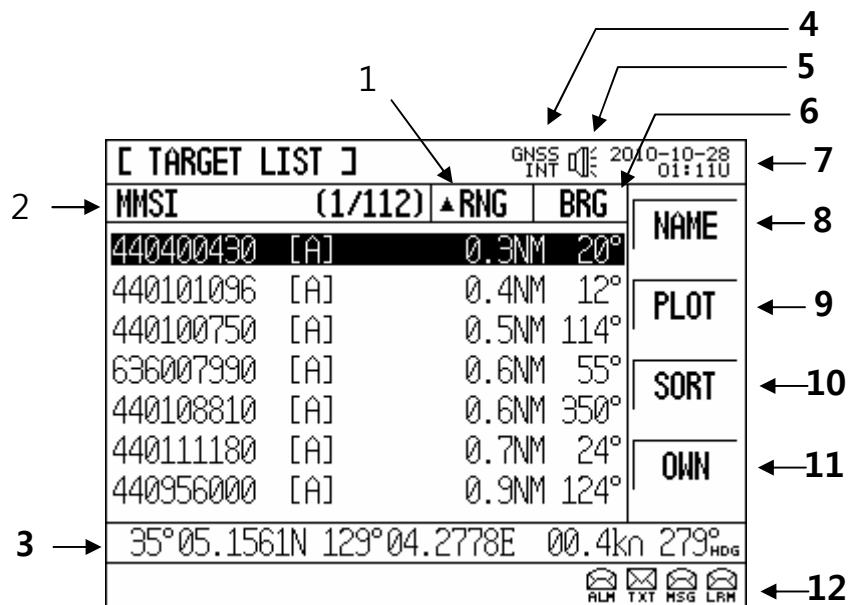

< Target data display >

1. Distance from vessel to target
2. MMSI (Maritime Mobile Service Identity)
3. Vessel's position, speed and information of azimuth
4. GNSS condition of receiving
5. ALARM sound
6. Azimuth angle (from current position to destination)
7. UTC (Universal Time Co-ordinate)
8. MMSI, select name of vessel
9. Plotter (graphic) function
10. Array in distance or azimuth angle
11. See information of own ship
12. Sent message, received message

### 3-3-2 How to set ship's name and MMSI

You can see all list of vessels which shares information with AIS and see the detailed information additionally.

When you press MMSI(F1), it displays MMSI number or ship's name. After choosing a vessel with arrow keys and Enter key, you can see the information what you selected.

| [ TARGET LIST ]                                     |         |       |      | GNSS INT 2010-10-28 01:11U |  |
|---|---------|-------|------|----------------------------|--|
| MMSI  | (1/112) | ▲RNG  | BRG  | NAME                       |  |
| 440400430   | [A]     | 0.3NM | 20°  |                            |  |
| 440101096   | [A]     | 0.4NM | 12°  |                            |  |
| 440100750   | [A]     | 0.5NM | 114° |                            |  |
| 636007990   | [A]     | 0.6NM | 55°  |                            |  |
| 440108810   | [A]     | 0.6NM | 350° |                            |  |
| 440111180   | [A]     | 0.7NM | 24°  |                            |  |
| 440956000   | [A]     | 0.9NM | 124° |                            |  |
| 35°05.1561N 129°04.2778E 00.4kn 279° <sub>Hdg</sub> |         |       |      |                            |  |
|   |         |       |      | ALH TXT MSG LRM            |  |

| [ TARGET LIST ]                                     |        |       |      | GNSS INT 2010-09-16 10:00L |  |
|---|--------|-------|------|----------------------------|--|
| NAME  | (4/91) | RNG   | ▲BRG | MMSI                       |  |
| KOREA NO.6  |        | 1.1nm | 2°   |                            |  |
| SITC QINGDAO  |        | 1.1nm | 3°   |                            |  |
| 440559000   |        | 0.8nm | 3°   |                            |  |
| SKY EVOLUTION                                       |        | 1.1nm | 7°   |                            |  |
| KANGNAM STAR  |        | 0.4nm | 9°   |                            |  |
| DONGJIN   |        | 0.6nm | 13°  |                            |  |
| NO1, HANLA  |        | 0.4nm | 15°  |                            |  |
| 35°05.1512N 129°04.2874E 00.5kt 012° <sub>Hdg</sub> |        |       |      |                            |  |
|   |        |       |      | ALH TXT MSG LRM            |  |

MMSI NUMBER

SHIP NAME

\* The Meaning of signs next to MMSI number show as below

- [ A ] : A class
- [ B ] : B class
- [ BS ] : Base Station
- [ N ] : A to N
- [ T ] : AIS SART

### 3-3-3 Array Objects

You can array objects in azimuth angle with SORT(F3) key.

| [ TARGET LIST ]                                     |         |       |      | GNSS INT 2010-10-28 01:11U |  |
|---|---------|-------|------|----------------------------|--|
| MMSI  | (1/112) | ▲RNG  | BRG  | NAME                       |  |
| 440400430   | [A]     | 0.3NM | 20°  |                            |  |
| 440101096   | [A]     | 0.4NM | 12°  |                            |  |
| 440100750   | [A]     | 0.5NM | 114° |                            |  |
| 636007990   | [A]     | 0.6NM | 55°  |                            |  |
| 440108810   | [A]     | 0.6NM | 350° |                            |  |
| 440111180   | [A]     | 0.7NM | 24°  |                            |  |
| 440956000   | [A]     | 0.9NM | 124° |                            |  |
| 35°05.1561N 129°04.2778E 00.4kn 279° <sub>Hdg</sub> |         |       |      |                            |  |
|   |         |       |      | ALH TXT MSG LRM            |  |

| [ TARGET LIST ]                                     |         |       |      | GNSS INT 2010-10-28 01:11U |  |
|---|---------|-------|------|----------------------------|--|
| MMSI  | (1/114) | RNG   | ▲BRG | NAME                       |  |
| 440547000   | [A]     | 1.9NM | 0°   |                            |  |
| 477415200   | [A]     | 1.1NM | 2°   |                            |  |
| 440132470   | [A]     | 1.1NM | 6°   |                            |  |
| 440101096   | [A]     | 0.4NM | 12°  |                            |  |
| 636013205   | [A]     | 1.1NM | 14°  |                            |  |
| 440400430   | [A]     | 0.3NM | 20°  |                            |  |
| 440111180   | [A]     | 0.7NM | 22°  |                            |  |
| 35°05.1555N 129°04.2780E 00.5kn 303° <sub>Hdg</sub> |         |       |      |                            |  |
|   |         |       |      | ALH TXT MSG LRM            |  |







Array in Distance

Array in azimuth angle

There's a triangle in the left of letter.

### 3-3-4 Message icon

There are 4 icons in the right and below corner which is for message sending and receiving.

| Icon  | Description   | Remark |
|---|---|--------|
|          | There is a message received.                                  |        |
|          | There is no message received or means it's been read already. |        |
| <br>ALM  | Alarm from transponder  |        |
| <br>TXT  | Each status from transponder                                  |        |
| <br>MSG  | Displays safety or other message received                     |        |
| <br>LRM | Displays message concerned with long range                    |        |

### 3-4 Plotter (Graphic) screen

#### 3-4-1 Explanation of plotter screen

If PLOT(F2) key is pressed, the unit displays plotter screen.

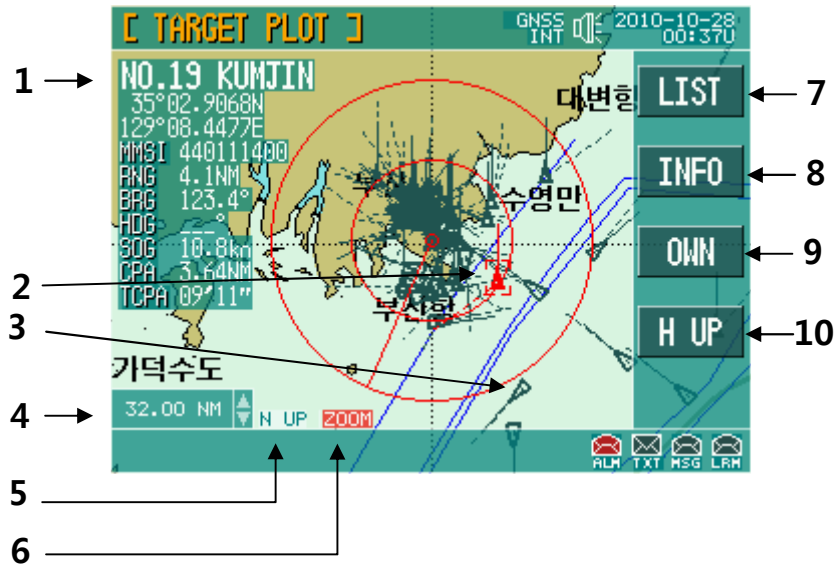

**< Plotter screen configuration >**

1. The information of selected vessel
2. The selected vessel
3. The other vessels received information
4. Distance of outer circle
5. Indication of Head-up /North-up
6. Direction key mode (ZOOM/MOVE/CURS)
7. View of data screen
8. View of other vessels
9. View of own vessel
10. Selection of Head-up/North-up

### 3-4-2 Chat direction / Distance settings

Available for displaying North-up and Heading-up using N-UP/H-UP(F4)key.



North-Up

Heading-Up

No. 8 key, No. 9 key and up/down key on keyboard accept to adjust nautical mile.

The unit can display from 0.25nm to 64nm. The distance information is on the bottom of left side of the screen

And the unit accepts to search the information of other vessels using direction key (right/left) After 10 minutes from plotter screen mode, the part of subject (The indication of [TARGET PLOT]) and function part (The indication of LIST, INFO, OWN, N-UP) is disappeared. If any key of F1, F2, F3 and F4 is pressed, the disappeared parts are displayed. And they will be disappeared again after 10 minutes.

### 3-4-3 Display of vessel information

Every time No.1 key is pressed, users can display or deleted the selected vessel's information.



Display of vessel information

No information

### 3-4-4 Indication of letter's information

If No.2 key is pressed, user can display or delete information of letter's information (name of place, depth & etc).



Display of information

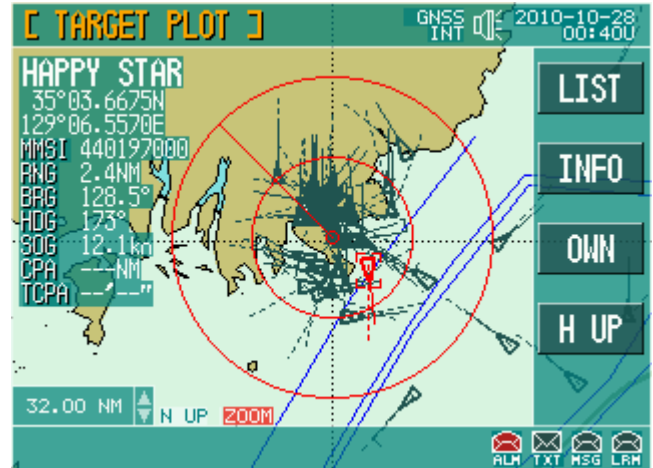

No information

### 3-4-5 Display of Range Ring

If No.3 key is pressed, user can display or delete Range Ring.



Display of information



No information

### 3-4-6 Display of chart

If No. 4 key is pressed, user can display or delete the chart on the screen.



Display of chart

No chart on the screen

### 3-4-7 Transfer of cart

If No.5 key is pressed, the "ZOOM" on the bottom is changed to "MOVE" in red. User can move the chart using direction keys.



The chart is on the center of screen

The moved chart

To display own vessel to the center of screen in condition of moved chart, it is required to press No.6 key. Next picture is showing the screen of chart moved to center of screen. If transfer mode is cancelled, the chart is drawn again with own vessel as the center.

### 3-4-8 Use of cursor

If No.7 key is pressed, cursor will appear. Users can move chart and select other vessels using cursor.



Chart is on the center of screen

Chart is moved

User can move cursor using direction key. If the cursor is get out of screen, the place cursor was located is moved to the center of screen. If cursor is moved to other vessel, information of the selected is shown on the top of the screen.

If cursor is appeared on the screen, information of longitude, latitude, range and bearing is shown on the bottom of the screen.

If No.7 key is pressed again, cursor function is cancelled. And chart is displayed with own vessel as the center

### 3-4-9 Changing screen / Data view

Press LIST(F1) key for changing to the screen of objects list mode of initial screen.

Information on the plotter screen is the standard information for the objects. For more detailed information, press INFO(F2) to display information as below pictures.

Using direction key, user can 3 separated pictures.

| [ TARGET SHIP DATA ] |              |             | GNSS INT 2010-10-28 00:46U |  |
|----------------------|--------------|-------------|----------------------------|--|
| NAME                 | NO.5 HAEDONG | [CA]        | EXIT                       |  |
| MMSI                 | 440228000    | Has DTE YES | LIST                       |  |
| IMO                  | 8410770      | EPFS GPS    | PLOT                       |  |
| C.SIGN               | DSE08        |             | MSG                        |  |
| ETA                  | 28 Oct 14:00 | S/C TYPE    | ▲ 1/3                      |  |
| DRAUGHT              | 5.4m         |             | ALM TXT MSG LRM            |  |
| DESTINATION          | MASAN        |             |                            |  |

PAGE 1

| [ TARGET SHIP DATA ] |              |  | GNSS INT 2010-09-16 09:39L |  |
|----------------------|--------------|--|----------------------------|--|
| Lat                  | 35°07.3503N  |  | EXIT                       |  |
| Lon                  | 129°04.3038E |  | LIST                       |  |
| COG                  | 166.9°       |  | PLOT                       |  |
| SOG                  | 00.0kt       |  | MSG                        |  |
| HDG                  | 110°         |  | ▲ 2/3                      |  |
| ROT                  | 0.0°/min     |  | ALM TXT MSG LRM            |  |
| NAU STATUS           | Moored       |  |                            |  |

PAGE 2

| [ TARGET SHIP DATA ]  |      |  | GNSS INT 2010-09-16 09:39L |  |
|-----------------------|------|--|----------------------------|--|
| GNSS Antenna Position |      |  | EXIT                       |  |
| A                     | 88 m |  | LIST                       |  |
| B                     | 11 m |  | PLOT                       |  |
| C                     | 8 m  |  | MSG                        |  |
| D                     | 9 m  |  | ▲ 3/3                      |  |
|                       |      |  | ALM TXT MSG LRM            |  |

PAGE 3

### 3-5 OWN SHIP DATA DISPLAY

Press OWN(F4) to see information related own ship and navigation.

| [ OWN SHIP DATA ] |              | GNSS INT 2010-09-16 09:46L |      |
|-------------------|--------------|----------------------------|------|
| NAME              | SAMYUNG-HO   | [A]                        | EXIT |
| MMSI              | 441123456    | Has DTE NO                 | LIST |
| IMO               | 123456789    | EPFS GPS                   | PLOT |
| C.SIGN            | STS          |                            |      |
| ETA               | 12 Nov 11:45 | S/C TYPE 71                |      |
| DRAUGHT           | 10.0m        | Cargo ships                |      |
| DESTINATION       | YOUNG-00     | IMO hazard cat.A           |      |
| ▲ 1/3 ▼           |              |                            |      |
| ALM TXT MSG LRM   |              |                            |      |

PAGE 1

| [ OWN SHIP DATA ] |              | GNSS INT 2010-09-16 09:46L |      |
|-------------------|--------------|----------------------------|------|
| Lat               | 35°05.1557N  |                            | EXIT |
| Lon               | 129°04.2737E |                            | LIST |
| COG               | 103.2°       |                            | PLOT |
| SOG               | 00.2kt       |                            |      |
| HDG               | 093°         |                            |      |
| ROT               | +720.0°/min  |                            |      |
| NAU STATUS        | not defined  |                            |      |
| ▲ 2/3 ▼           |              |                            |      |
| ALM TXT MSG LRM   |              |                            |      |

PAGE 2

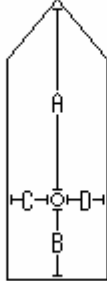
| [ OWN SHIP DATA ]     |   | GNSS INT 2010-09-16 09:46L |      |
|-----------------------|---|----------------------------|------|
| GNSS Antenna Position |   |                            | EXIT |
| Internal              |  | External                   | LIST |
| A 155 m               |   | A 75 m                     | PLOT |
| B 35 m                |   | B 115 m                    |      |
| C 63 m                |   | C 23 m                     |      |
| D 15 m                |   | D 55 m                     |      |
| ▲ 3/3 ▼               |   |                            |      |
| ALM TXT MSG LRM       |   |                            |      |

PAGE 3

Ship name, MMSI number, IMO number, call sign, ship type, ETA, destination & etc are shown on page 1.

Longitude, latitude, CDG(Course Over Ground), SOG(Speed Over Ground), heading information, ROT(Rate of Turn), Navigation status & ETC are shown on page 2.

Information for internal & external GNSS position are shown on page .

## 3-6 COMPOSITION & USAGE OF MENU

### 3-6-1 Composition of menu

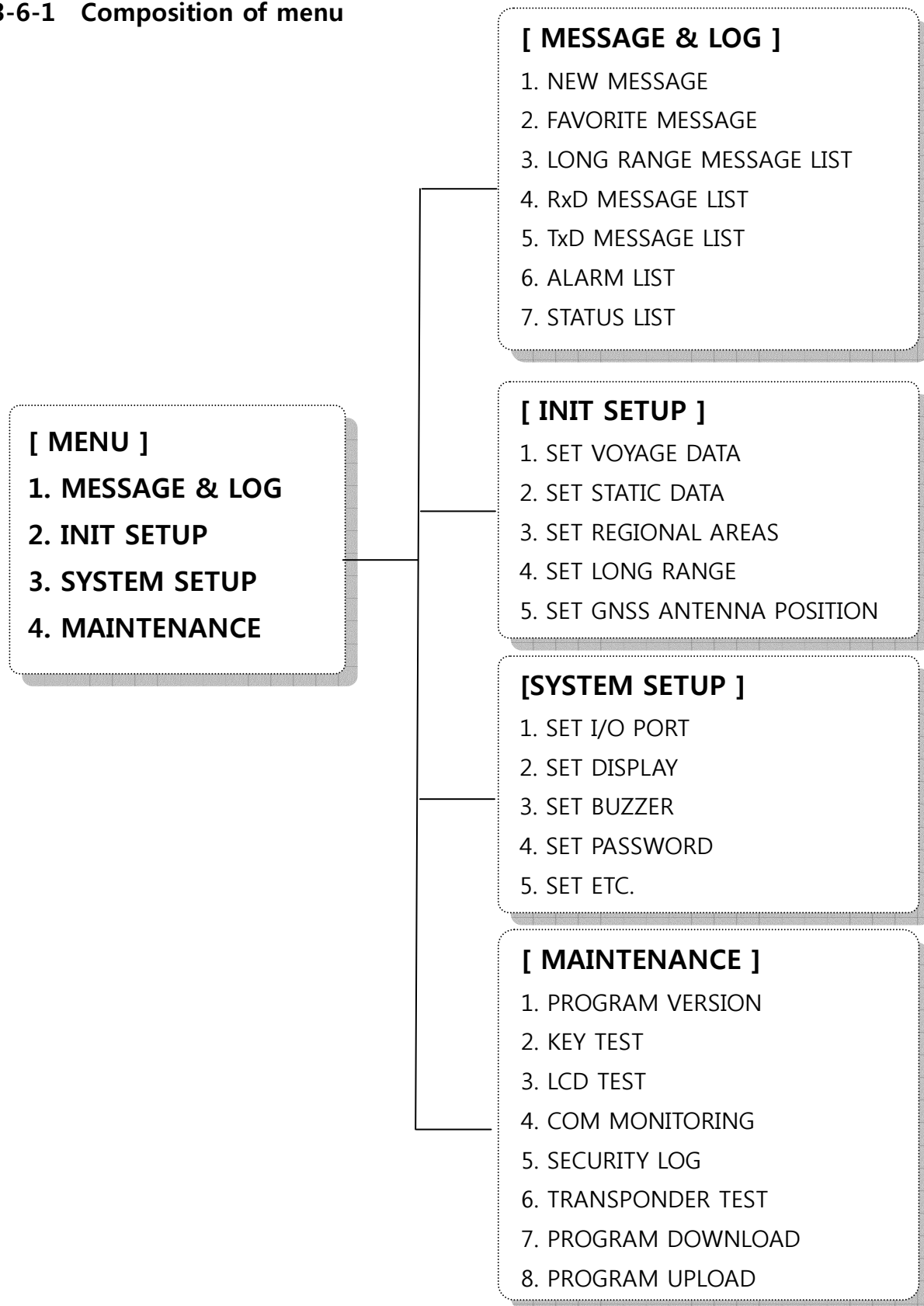

### 3-7 MESSAGE SETUP

Message TX, message RX, alarm & alarm status from system are displayed.

#### 3-7-1 NEW MESSAGE

Press "MENU" → "1.MESSAGE & LOG" → "1. NEW MESSAGE" to display the below picture. Send the written message to other party.

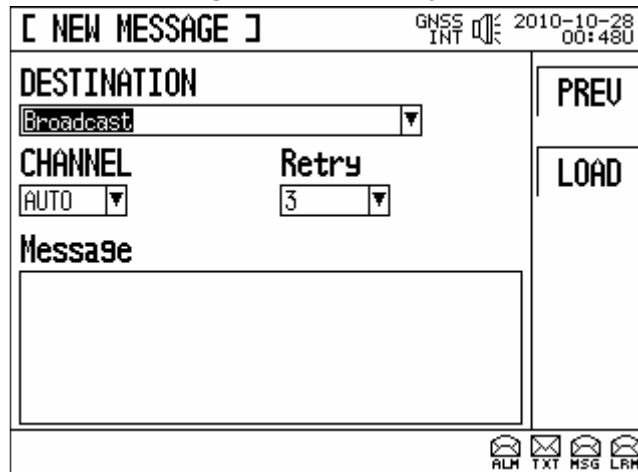

NEW MESSAGE screen

- ◆ DESTINATION : Select broadcast, MMSI number & ship name.
- ◆ CHANNEL : Select type of channels.
- ◆ Retry : Select the number of retransmissions.
- ◆ Message : Write a message.
- ◆ "LOAD(F2)" button : It allows to select favorite messages and used messages on [FAVORIT MESSAGE] SCREEN.
- ◆ "SAVE(F3)" button : It allows to save the written message in [FAVORITE MESSAGES].
- ◆ "SEND(F4)" button : It allows to send the message.

### 3-7-2 FAVORITE MESSAGES

Press "MENU" → "1.MESSAGE & LOG" → "2. FAVORITE MESSAGE" to display the below screen. This function is used to make new message and send the selected data using saved messages.

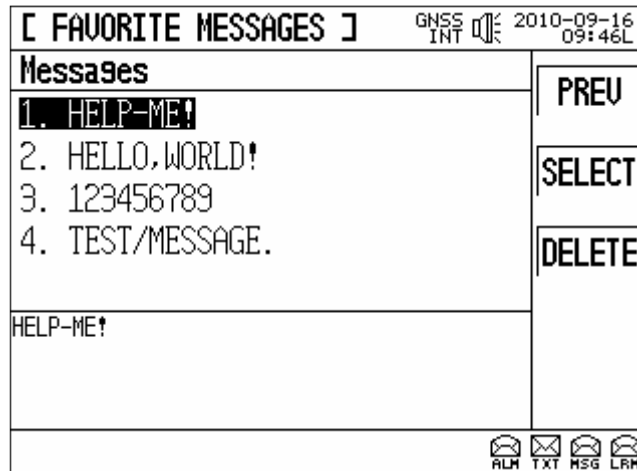

FAVORITE MESSAGES screen

Press SELECT(F2) to change to [New Message] screen. Press DELETE(F3) to display the screen for selecting to delete message or not. If YES(F1) is pressed, the message is deleted. If NO(F2) is pressed, the screen is changed to [FAVORITE MESSAGES] mode.

### 3-7-3 LONG RANGE MESSAGE

Press "MENU" → "1.MESSAGE & LOG" → "3.LONG RANGE MESSAGE LIST" to display below screen. This function allows to see information for the reception date/time & requester regarding the received long range message.

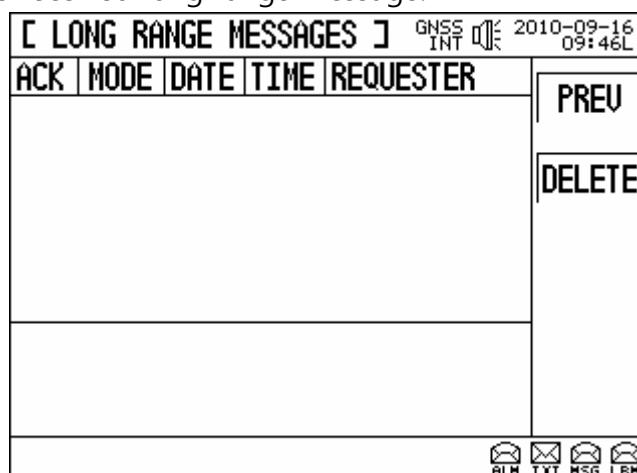

LONG RANGE MESSAGE screen

If DELETE(F2) button is pressed, the received data is deleted. ACK(F3) is a function to reply for inquiries of other parties.

### 3-7-4 RxD MESSAGE

Press "MENU" → "1.MESSAGE & LOG" → "4.RxD MESSAGE LIST" to display the below screen. RxD Message show reception date, type (broadcast, individual cases), time, sender and received message.

| [ RxD MESSAGES LIST ] |           |           | GNSS INT 2010-10-28 04:06U |
|-----------------------|-----------|-----------|----------------------------|
| R                     | MSG TYPE  | SENDER    | ARRIVED                    |
| ✓                     | AD SAFETY | 123456789 | 09-15 09:00                |
| ✓                     | AD SAFETY | 123456789 | 09-15 08:59                |
| @@TEST                |           |           |                            |
|                       |           |           | PREU                       |
|                       |           |           | FRWD                       |
|                       |           |           | REPLY                      |
|                       |           |           | DELETE                     |

RxD MESSAGE LIST screen

EX) In the above pictures, Message type is broadcast, MMSI no. of sender is 123456789, time is September 15, 09:00, message contents is "@@TEST".

"FRWD(F2)" : To send messages to other parties.

"REPLY(F3)" : To reply messages to the senders.

"DELETE(F4)" : To delete the contents of messages.

### 3-7-5 TxD MESSAGE

Press "MENU" → "1.MESSAGE & LOG" → "5. TxD MESSAGE LIST" to display the below screen. User can check the transmitted date and time & etc.

| [ TxD MESSAGES LIST ] |           |           | GNSS INT 2010-09-16 09:48L |
|-----------------------|-----------|-----------|----------------------------|
| S                     | MSG TYPE  | RECEIVER  | SENT                       |
| ✓                     | AD SAFETY | 107374182 | 09-16 00:48                |
| ✓                     | AD SAFETY | 107374182 | 09-16 00:47                |
| ✓                     | AD SAFETY | 123456789 | 09-16 00:47                |
| HELP-ME?              |           |           |                            |
|                       |           |           | PREU                       |
|                       |           |           | FRWD                       |
|                       |           |           | DELETE                     |

TxD MESSAGE LIST screen

EX) In the above picture, transmitted message type is individual case, 123456789 is MMSI

number of the ship received message.

“PREV(F1)” : To return to initial screen.

“FRWD(F2)” : To send messages to other parties.

“DELETE(F4)” : To delete data.

### 3-7-6 ALARM MESSAGE

Press “MENU” → “1.MESSAGE & LOG” → “6. ALARM LIST” to display the below screen.

User can check the time happened alarm, the status of acknowledge of alarm happened and description of alarm.

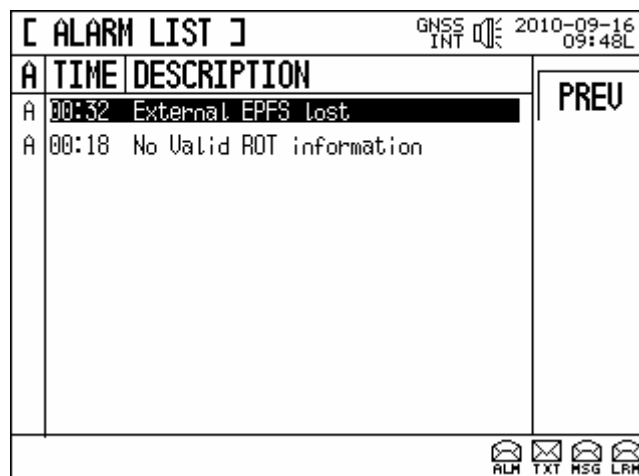

ALARM LIST screen

- ◆ A : Acknowledge
- ◆ TIME : The time alarm rang
- ◆ DESCRIPTION : The description of alarm

The below is the explanation about above alarm list screen.

Information for External position & related data is lost at 00:32.

### 3-7-7 STATUS MESSAGE

Press "MENU" → "1.MESSAGE & LOG" → "7. STATUS LIST" to display the below screen.

User can see the information regarding the status of the unit in real time.

| [ STATUS LIST ] |                               | GNSS 2010-09-16<br>INT 09:48 |
|-----------------|-------------------------------|------------------------------|
| TIME            | DESCRIPTION                   | PREV                         |
| 09-16 00:48     | UTC clock ok                  |                              |
| 09-16 00:48     | No Valid ROT information      |                              |
| 09-16 00:47     | Channel management parameters |                              |
| 09-16 00:44     | internal GNSS in use          |                              |
| 09-16 00:44     | internal SOG/COG in use       |                              |
| 09-16 00:19     | Heading valid                 |                              |

ALM TXT MSG LRM

STATUS LIST screen

The below is the explanation about above status message screen

- ◆ 09-16 00:19 : AIS: Heading valid : Information for heading is correct.
- ◆ 09-16 00:44 : AIS: Internal SOG/COG in use : Internal SOG/COG is used.
- ◆ 09-16 00:44 : AIS: Internal GNSS in use : Internal GNSS is used.
- ◆ 09-16 00:48 : no valid ROT information : There is no ROT(Rate Of Turn) information.
- ◆ 09-16 00:48 : AIS: UTC clock ok : UTC clock is valid.

### 3-8 INITIAL SETUP

The initial setup display is divided into 5 (five) sub-items as follows;

It includes SET VOYAGE DATA, SET STATIC DATA, SET REGIONAL AREAS, SET LONG RANGE, SET GNSS ANTENNA POSITION etc.

Order to do the initial setup, must input password.



#### 3-8-1 VOYAGE DATA

From “MENU” button, go to “2. INIT SETUP” and go to “1. SET VOYAGE DATA”, then a following screen will appear.

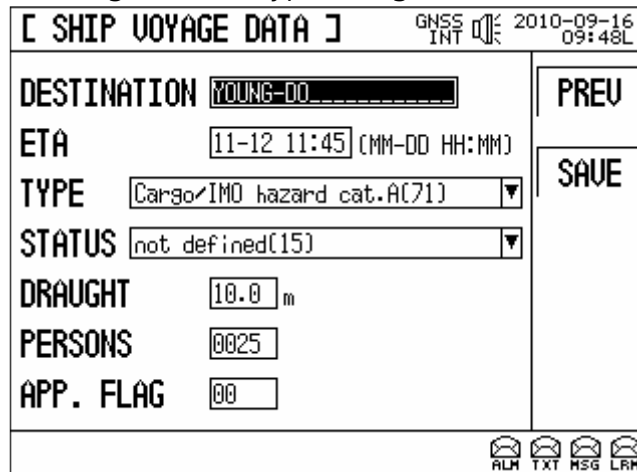
Navigation related data, that is to say, destination (Max. 20 characters’ input available), ETD, ETA, number of crewmen, draught, vessel type, navigation status etc. can be input.



VOYAGE DATA SCREEN

For any changes or corrections, use  or  button (up and down arrow) or # key button to move the wanted item.



### 3-8-2 STATIC DATA

From "MENU" button, go to "2. INIT SETUP" and go to "2. SET STATIC DATA", then a following screen will appear.

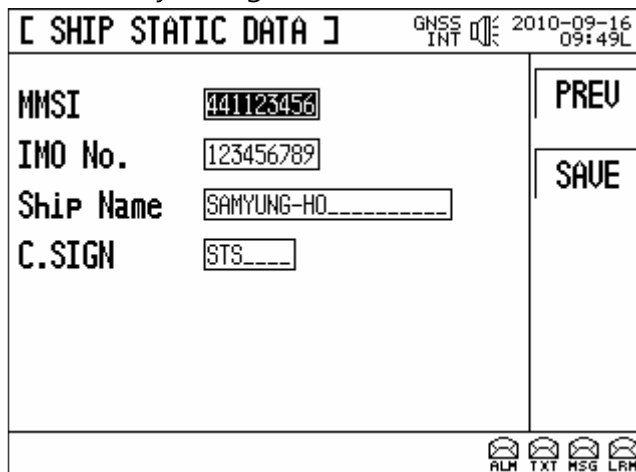
This screen is for inputting the static data on vessels that are in use. Ship name means the name of the ship (Max. 20 characters' input available) and Call Sign means the call number (Max. 7 characters' input available) respectively. The password should not be released because no one is allowed to freely change the data.



STATIC DATA SCREEN

For any changes or corrections, use  or  button (up and down arrow) or # key button to move the wanted item.

### 3-8-3 REGIONAL AREAS

From "MENU" button, go to "2. INIT SETUP" and go to "2. SET STATIC DATA", then a following screen will appear.

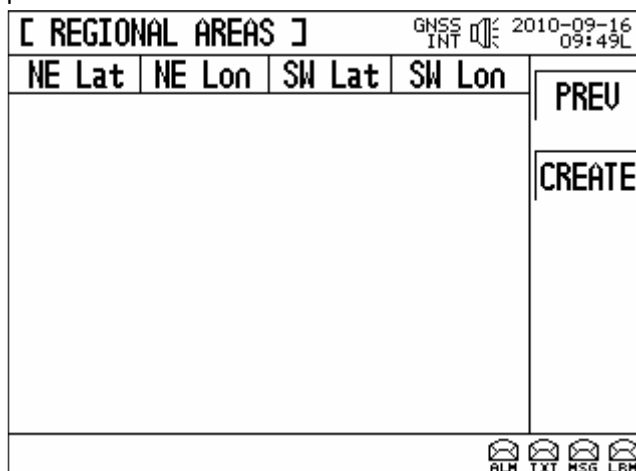



REGIONAL AREAS SCREEN

In the display, when press  "CREATE" button, it is ready to input the details of new

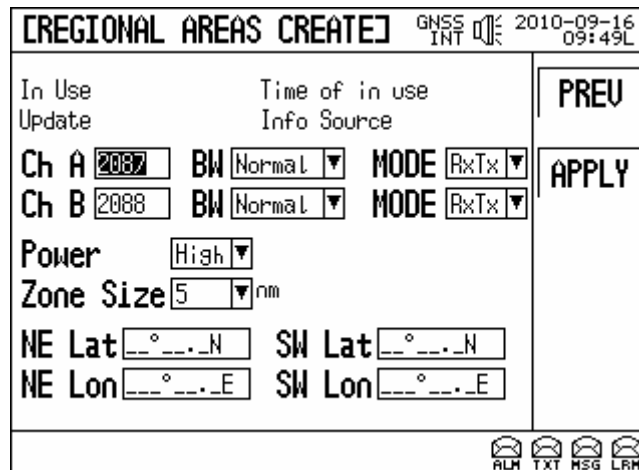
regional operation.



REGIONAL AREAS CREATE SCREEN

For any changes or corrections, use  or  button (up and down arrow) or # key button to move the wanted item.



### 3-8-4 LONG RANGE MODE

From "MENU" button, go to "2. INIT SETUP" and go to "4. SET LONG RANGE", then a following screen will appear.

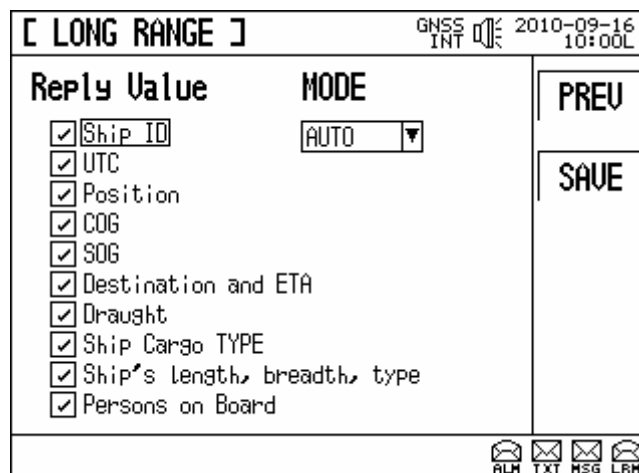
This is designed to set up whether an automatic response or a passive response should be made from long-range communication terminal such as INMARSAT-C vessel station regarding the request for data on own vessel.



LONG RANGE SCREEN

For any changes or corrections, use  or  button (up and down arrow) or # key button to move the wanted item.

### 3-8-5 GNSS ANTENNA POSITION

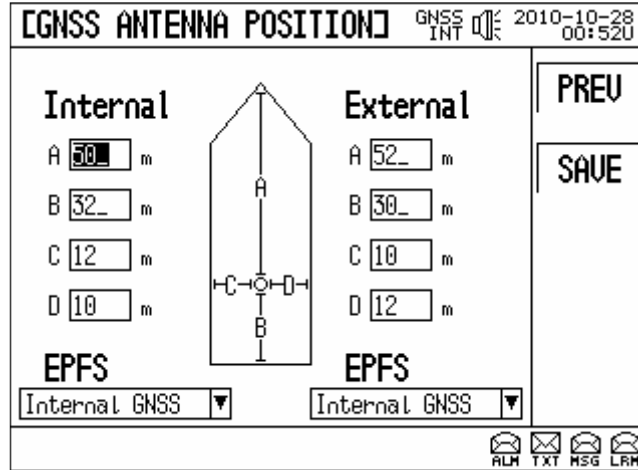

From "MENU" button, go to "2. INIT SETUP" and go to "4. SET GNSS ANTENNA POSITION", then a following screen will appear.

The function is to set a position of internal GPS antenna and external GPS antenna.



GNSS ANTENNA POSITION SCREEN

The internal means a position of internal GNSS antenna and the external on right side means a position of external GNSS antenna.

For any changes or corrections, use  or  button (up and down arrow) or # key button to move the wanted item.

### 3-9 SYSTEM SETUP

As of SI-30A's a function to set a definition of baud rate (SET I/O PORT) with MKD, transponder or external equipment, and a definition of luminosity and brightness adjustment (SET DISPLAY) alarm of MKD display, and a noise out of keypad (SET BUZZER) and to set alteration of password (SET PASSWORD), and to set initialization of system (INITIALIZE SYSTEM).

#### 3-9-1 SET I/O PORT TRANSMIT RATE

From "MENU" button, go to "3. SYSTEM SETUP" and go to "1. SET I/O PORT", then a following screen will appear.

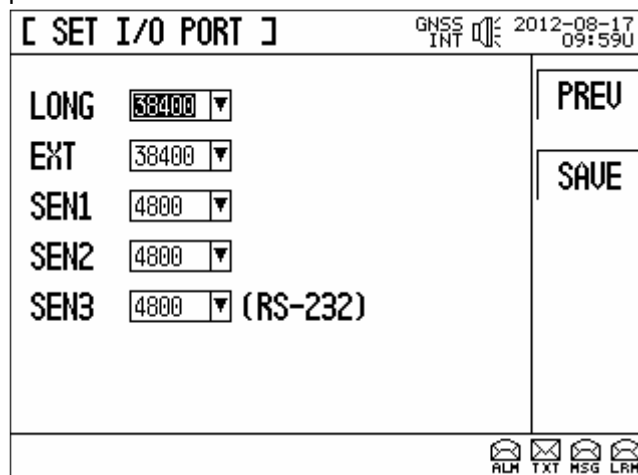

SET I/O PORT SCREEN

It displays following screen that enables to change the port relative items and port baud rate Port definition by item is as follows.

- ◆ LONG : Long Range Port(**38400**/4800)
- ◆ EXT : External Display(**38400**/4800)
- ◆ SEN1 : Sensor Port1(**4800**/34800)
- ◆ SEN2 : Sensor Port2(**4800**/34800)
- ◆ SEN3 : Sensor Port3(**4800**/34800) = RS232 IN / OUT
- ◆ 그림 참고

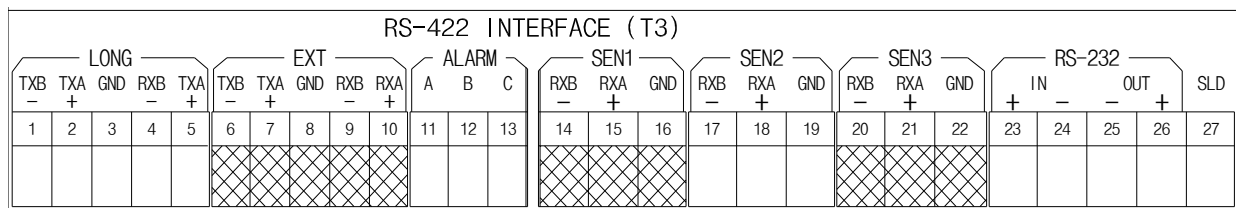



### 3-9-2 BRIGHTNESS ADJUSTMENT

From "MENU" button, go to "3. SYSTEM SETUP" and go to "2. SET DISPLAY", then a following screen will appear.

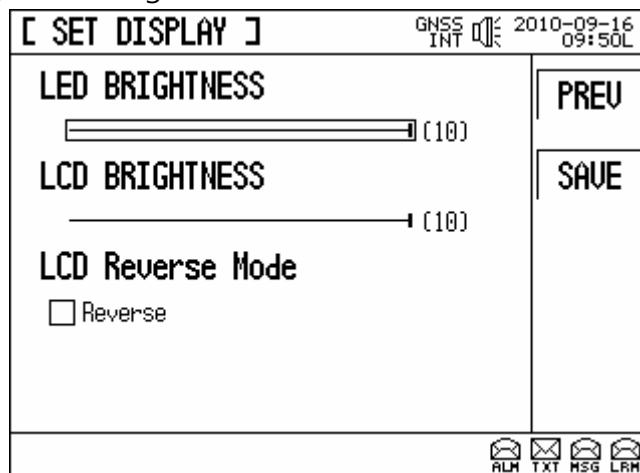
It is available to adjust and modify LCD brightness, LED brightness of Keypad as a composition of moving to left / light on a screen.



SET DISPLAY SCREEN

Adjust for LED of Keypad is available by using  or  button on LD BRIGHTNESS, and it will adjust up to 10 (ten) levels of brightness of LED.

This is a function of DAY/NIGHT Reverse on the LCD screen and this is necessary mostly in night navigation as function that allows users to reserve the display.

### 3-9-3 SET BUZZER

From "MENU" button, go to "3. SYSTEM SETUP" and go to "2. SET BUZZER", then a following screen will appear.

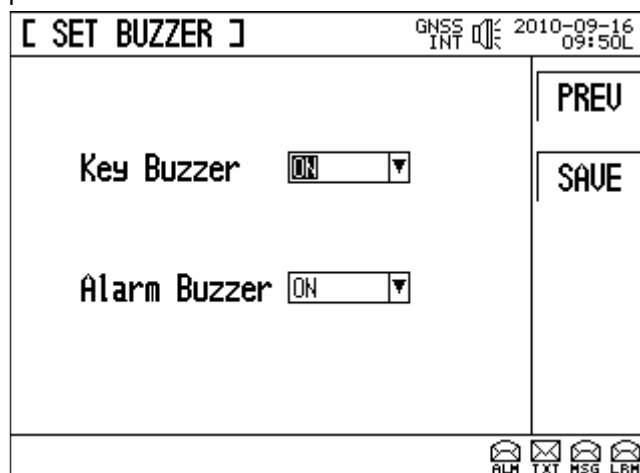

SET BUZZER SCREEN

- ◆ Key Buzzer: a function that allows users to turn on/off the beeping sound, which

occurs when various buttons of MKD pad are pushed.

- ◆ Alarm Buzzer: a function enabling users to set up the occurrence of various alarm signals delivered from transponder under systems operation. The buzzer/on creates sound while the buzzer/off eliminates sound.

### 3-9-4 SET PASSWORD

From “MENU” button, go to “3. SYSTEM SETUP” and go to “4. SET PASSWORD”, then a following screen will appear.

For password change, maximum of 6 characters or digits can be input.

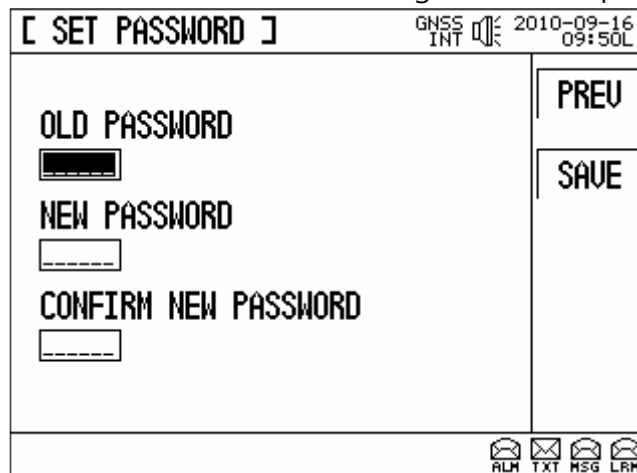

SET PASSWORD SCREEN

\* The password should not be released because no one is allowed to freely change the data.

### 3-9-5 SET ETC.

From “MENU” button, go to “3. SYSTEM SETUP” and go to “5. SET ECT”, then a following screen will appear.

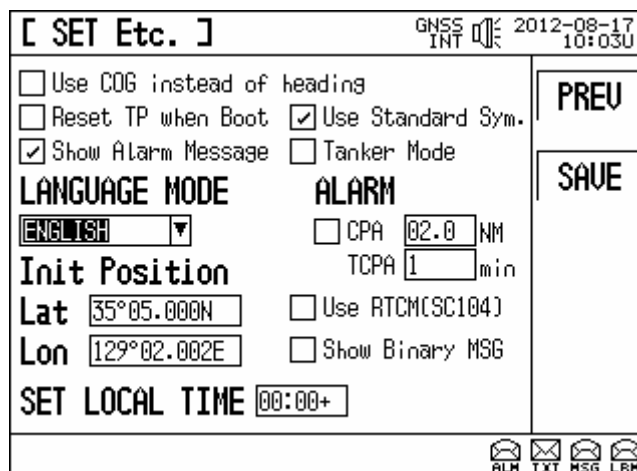

SET ETC SCREEN

- ◆ **Use of COG instead of heading:** to display COG value instead of HDG value indicated on a TARGET LIST or set a position of map's initial value to be indicated

before receiving a position of a ship's value on a plotter screen.

- ◆ **Reset TP when Boot:** When MKD starts, transponder will be restart.
- ◆ **Use Standard Sym.:** use of standard shape of symbol for the target.
- ◆ **Show Alarm Message:** it can be setup as warning with alarm message.
- ◆ **LANGUAGE MODE:** Choose one of following language (in ENGLISH, KOREAN, and/or CHINESE)
- ◆ **CPA/TCPA ALARM:** it can be select as warning with alarm between current distance of the ship position (CPA) or Time to Closest Point of Approach (TCPA).
- ◆ **Init Position:** input ship's own current initial position.
- ◆ **SET LOCAL TIME:** can input any time difference based on Universal Time Coordinated (UTC).
- ◆ **Use RTCM(SC104) :**DGNSS
- ◆ **Show Binary MSG**

### 3-10 MAINTENANCE

System maintenance is a function to test and keep main functions of system and the users can test the functions by using the function of maintenance anytime. Main function is PROGRAM VERSION, KEY TEST, LCD TEST, COM MONITORING between transponder and MKD, SECURITY LOG and so on.

#### 3-10-1 PROGRAM VERSION

From "MENU" button, go to "4. MAINTENANCE" and go to "1. PROGRAM VERSION", then a following screen will appear.

Screen will displayed with each transponder and MKD S/W version.

#### 3-10-2 KEY TEST

From "MENU" button, go to "4. MAINTENANCE" and go to "2. KEY TEST", then a following screen will appear.

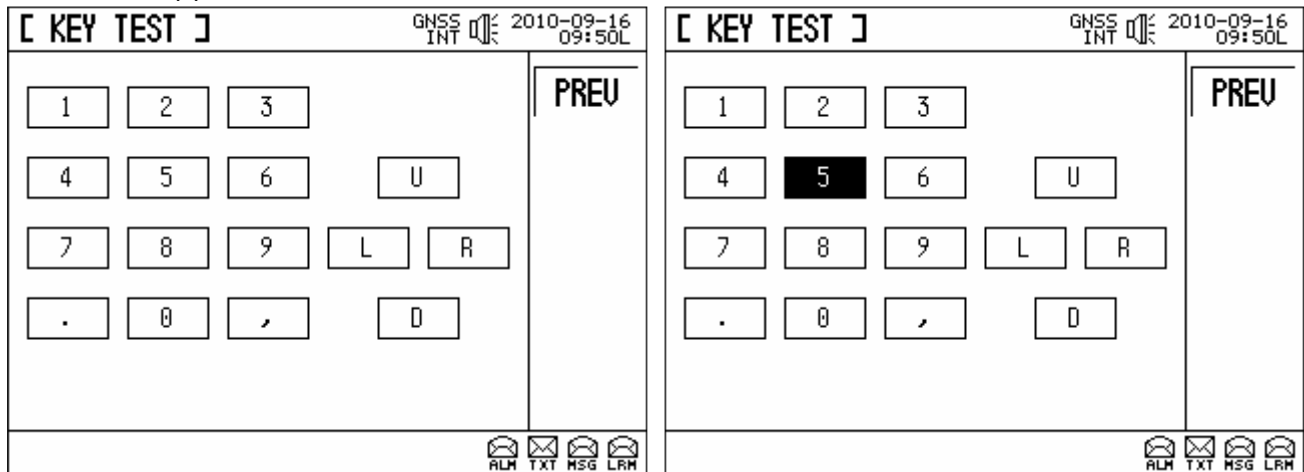

KEY TEST SCREEN

ACTUAL KEY TESTING SCREEN

For test method, when press a key on the Keypad, the appropriate item will turns to black. In example, when press No. 5 pad on the Keypad, a following screen appears.

### 3-10-3 LCD TEST

From "MENU" button, go to "4. MAINTENANCE" and go to "3. LCD TEST", then a following screen will appear.

For test method, when press "ENT" button, it turns to five different type of colors.

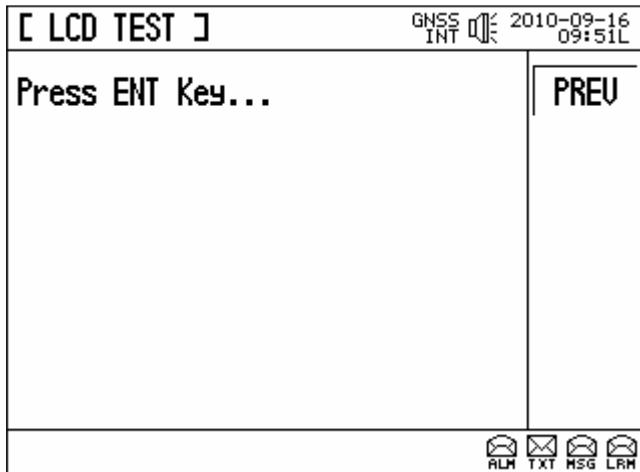

BEFORE LCD TEST SCREEN



AFTER TEST SCREEN CHANGES COLOR

### 3-10-4 COM MONITORING

From "MENU" button, go to "4. MAINTENANCE" and go to "4. COM MONITORING", then a following screen will appear.

COM MONITORING test is to check the exchange of information between Transponder and MKD.

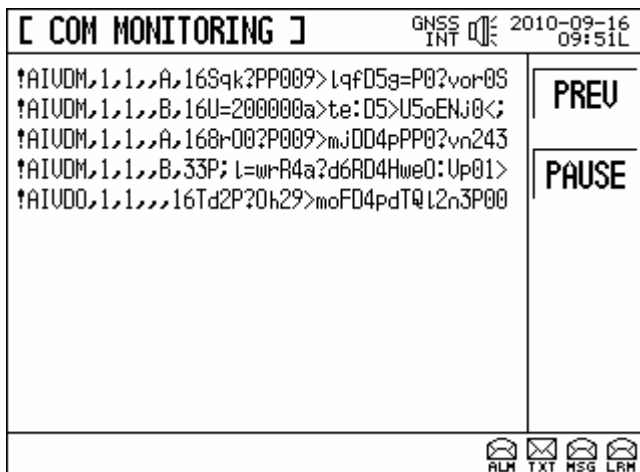

MONITORING SCREEN

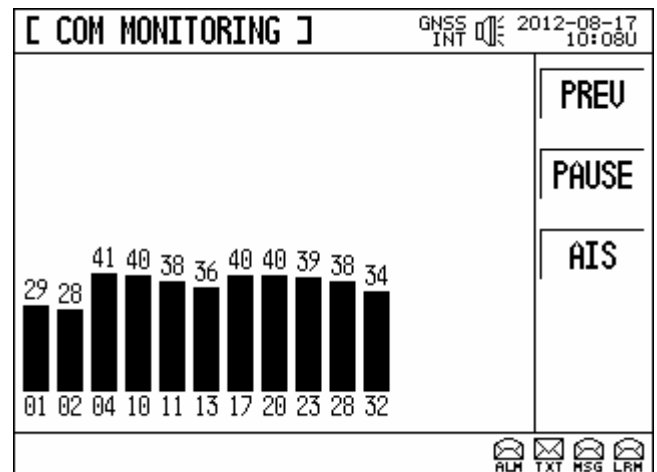

GPS SCREEN

### 3-10-5 SECURITY LOG

From "MENU" button, go to "4. MAINTENANCE" and go to "4. SECURITY LOG", then a following screen will appear.

It is a function to record the occurrence took place like System ON/OFF record, VSWR error and System Alarm.

| [ SECURITY LOG ] |         |              |       | GNSS INT 2010-09-16 09:51L |
|------------------|---------|--------------|-------|----------------------------|
| ALARM            | DUR.    | DATE         | TIME  | PREV                       |
| Power off        | 0000:21 | on 10 Jun 05 | 01:30 |                            |
| Power off        | 0000:20 | on 10 Jun 05 | 01:02 |                            |
| Power off        | 0000:27 | on 10 Jun 05 | 00:28 |                            |
| Power off        | 0744:11 | on 10 Jun 05 | 00:00 |                            |
| Power off        | 0000:21 | on 10 Jun 05 | 23:35 |                            |

SECURITY SCREEN

### 3-10-6 TRANSPONDER TEST

From "MENU" button, go to "4. MAINTENANCE" and go to "6. TRANSPONDER TEST", then a following screen will appear.

TRANSPONDER TEST executes TRANSCIEVER TEST of transponder, RECEIVER TEST, SET PARAMETER and IITIALIZE SYSTEM; however, it has to be conducted by technician or the expert.

| [ TRANSPONDER TEST ]       |  | GNSS INT 2010-09-16 09:51L |
|----------------------------|--|----------------------------|
| <b>1. TRANSCIEVER TEST</b> |  | PREV                       |
| 2. RECEIVER TEST           |  |                            |
| 3. SET PARAMETER           |  |                            |
| 4. INITIALIZE SYSTEM       |  |                            |

TRANSPONDER TEST SCREEN

### 3-10-7 PROGRAM DOWNLOAD

From "MENU" button, go to "4. MAINTENANCE" and go to "7. PROGRAM DOWNLOAD", then a following screen will appear.

PROGRAM DOWNLOAD is for executing upgrade for software. This function is to delete a previous program as a downloading into MKD connecting to external PC and reinstall a new program.

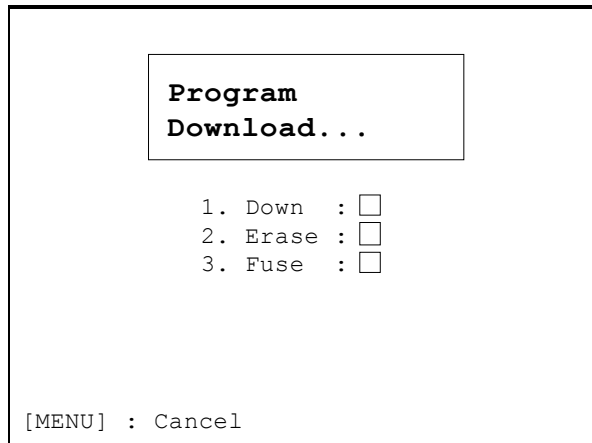

PROGRAM DOWLOAD, ERASE, OR FUSE SCREEN

**Down:** Downloading a new program into MKD

**Erase :** Deleting a previous program

**Fuse :** Indicating a downloaded program to MKD

### 3-10-8 PROGRAM UPLOAD



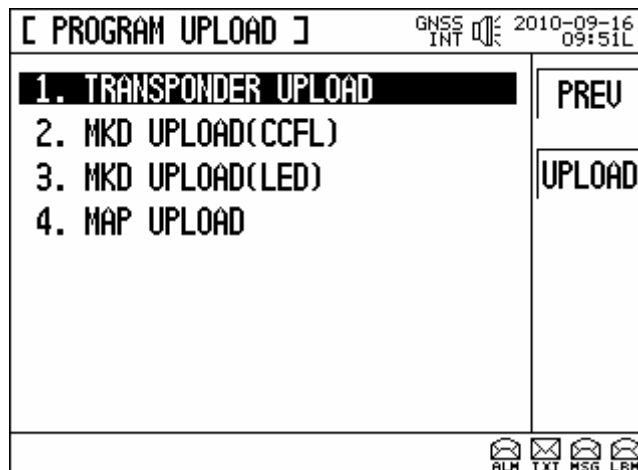

From "MENU" button, go to "4. MAINTENANCE" and go to "8. PROGRAM UPLOAD", then a following screen will appear.

PROGRAM UPLOAD is for executing upgrade of other MKD software or of transponder software. This function is for system maintenance only so that it doesn't be included into a service manual.



### 3-11 The explanation signs of AIS

This equipment of AIS shows 4 different signs and each sign has functions as below.

- ◆  : The sign for the pausing ship
- ◆  : The sign for the moving ship
- ◆  : The sign when you choose a ship.
- ◆  : The sign for the ship which is in danger

The meaning of signs show as below

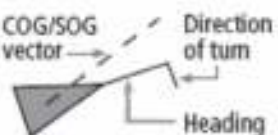

- ◆ COG/SOG : It means Course of ground, Speed of Ground.
- ◆ Heading : It means the azimuth of vessel's head.
- ◆ Direction of turn : It means that the ship's direction.

In the event of signing (4) case, it distinguishes dangerous ship after considering CPA/TCPA. CPA/TCPA means as follow

- ◆ CPA(Closest Point to Approach)
- ◆ TCPA(Time for Closest Point Approach)

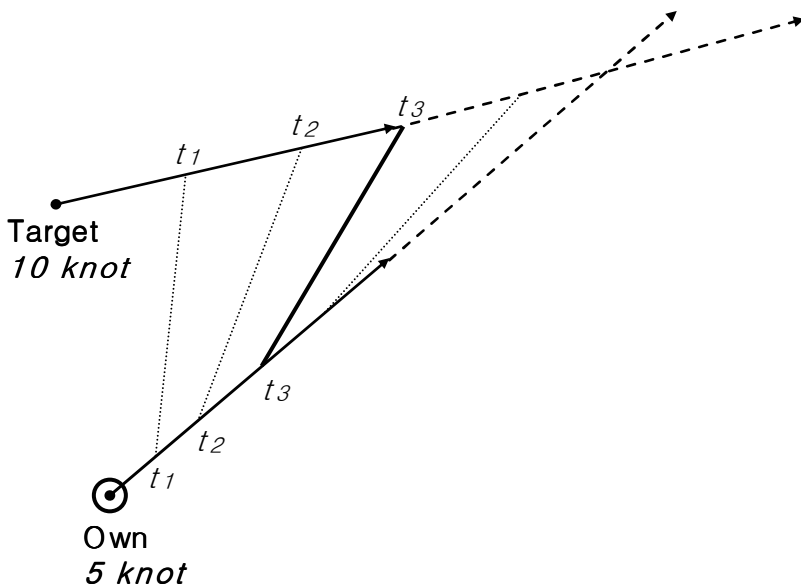

You get the distance each time between 2 points while the ship(Own) and the other ship(Target) cruise with 5Knot, 10 Knot as the picture above. When the time should be  $t_1$ ,  $t_2$ ,  $t_3$ , ...,  $t_n$ , if you get the distance, you can learn that  $t_3$  is the closest point. At that moment, the point should be CPA and the time when it arrives at  $T_3$ , should be TCPA.

## 4. The Installation method and explanation equipment

### 4-1 The explanation method

#### 4-1-1 Front side

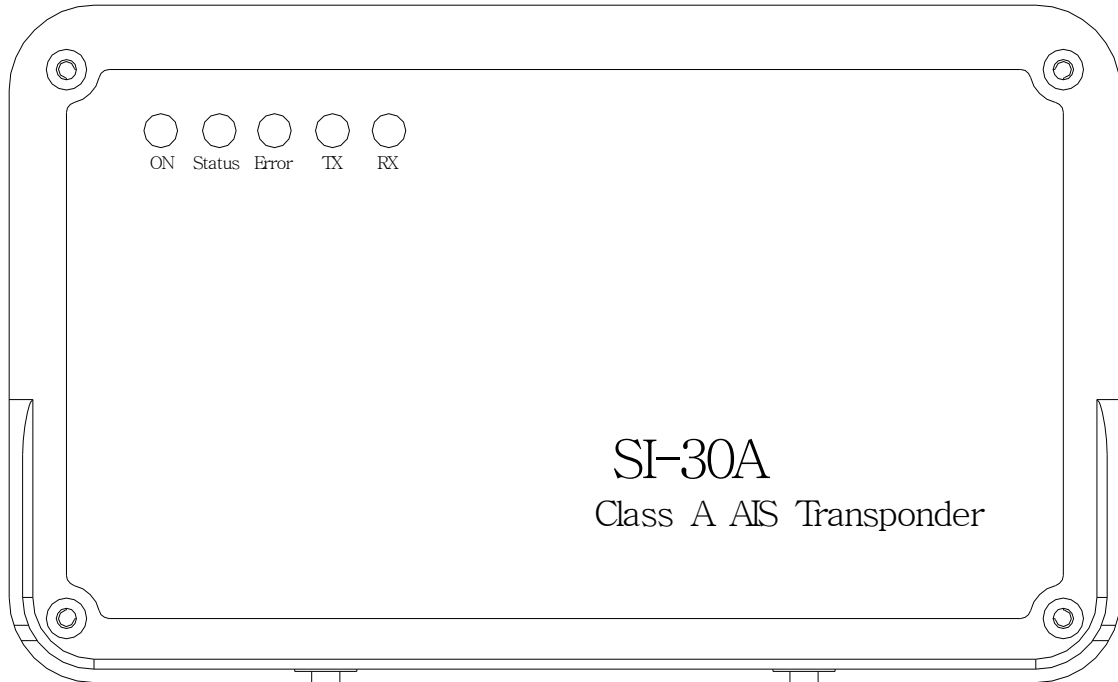

| LED    | Function   | Remark    |
|--------|--|-----------|
| ON     | The LED light is on when the power is connected.   | Red LED   |
| STATUS | Status LED light is on when the Transponder receives UTC Sync information via Internal GPS receiver, UTC Sync information is complied. | Green LED |
| ERROR  | The error message is on when Transponder has defects or faults in products, when it is on the equipment's problem and inside errors.   | Red LED   |
| TX     | When you send AIS data if you receive normally.  | Red LED   |
| RX     | When you send AIS data if you transfer normally.   | Green LED |

## 4-1-2 Back Side

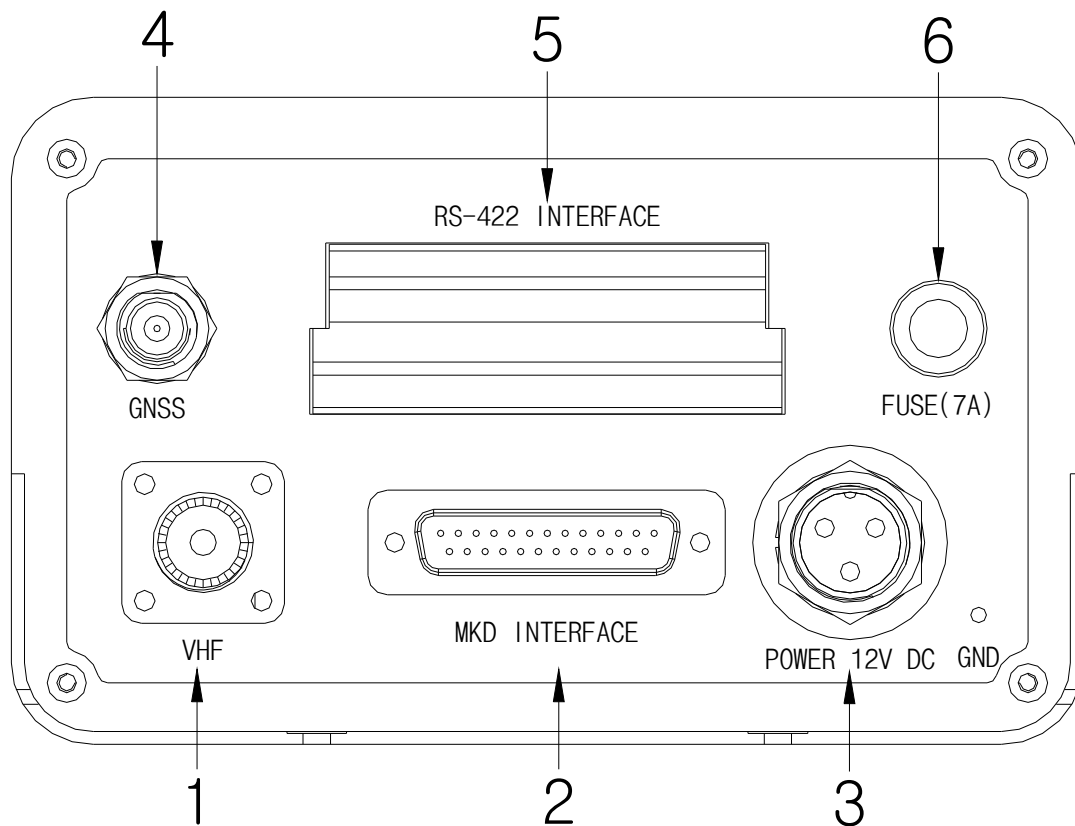

### 1. VHF – ANT

Receiving the signal of VHF .

### 2. MKD INTERFACE And Power (RS-422)

The port for the communication with MKD, it communicates with the form of NMEA0183 DATA.

### 3. POWER

Input from the power supply, or Battery. (Main unit: DC +12V. / SP-700 : DC13.8V)

### 4. GPS – ANT

Receiving the GPS signal.

### 5. RS-422 INTERFACE

The port for outer signal and the communication with other equipments, it is used as NMEA0183 DATA.

### 6. FUSE(7A)

It is used 7A fuse of power.

## 4-2 The method of installation

SI-30A is designed for installing to the existing bridge easily, it shows the occupation of general system on outer wiring diagram in Annex.

We suggest that all components such as VHF antenna, Plotter, MKD should be installed According to the instruction as manufacturer provides.

## 4-3 Main Unit installation

The method of installation SI-30A is as below.

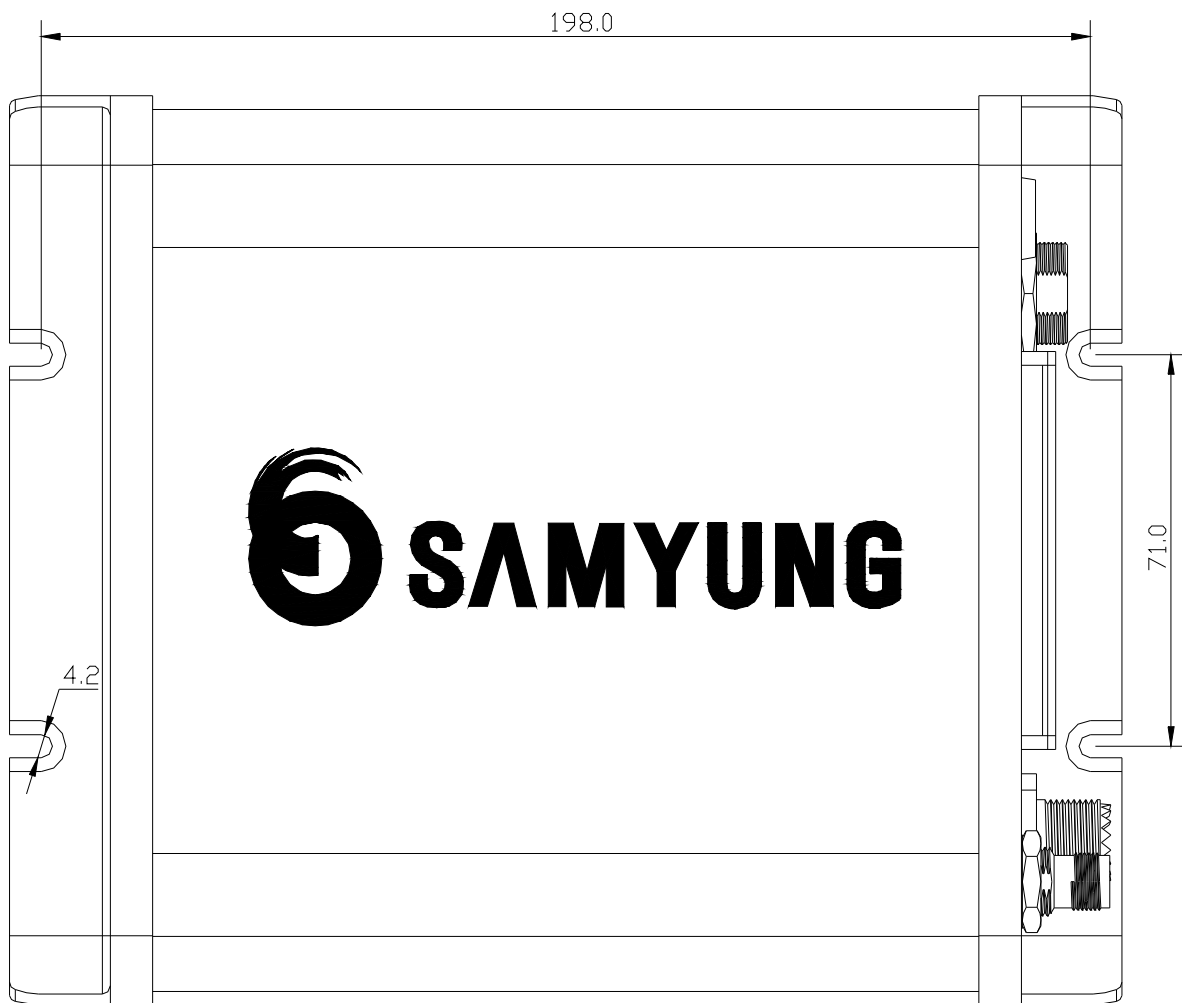

The installation of SI-30A should be considered to approach other outer equipments easily. 3P connector which is placed on back of main unit, is for power supply. It can be connected, if No.1 is (+), No3. is(-).

The cable of IEC/NMEA DATA should be connected to data port on back of main unit(refer to outer wiring diagram of SI-30A in Annex).

### 4-3-1 How to setup Antenna

VHF Antenna is for keeping TX/RX in good performance, please kindly refer below instructions when you install VHF Antenna.

Generally, VHF Antenna should be installed in high position as far away from other equipment. And it should be away at least 2M from the conductivity materials. Further, it should not be installed in near by vertical material and secured a 360 view.

It also need to be installed 2M away form high-voltage material and beam of their TX signal such as TX Radar, Radio and so on. Do not install 2 antennas on the same height. If you need to install 2 antennas on the same height, it should be at least 2M away from each other.

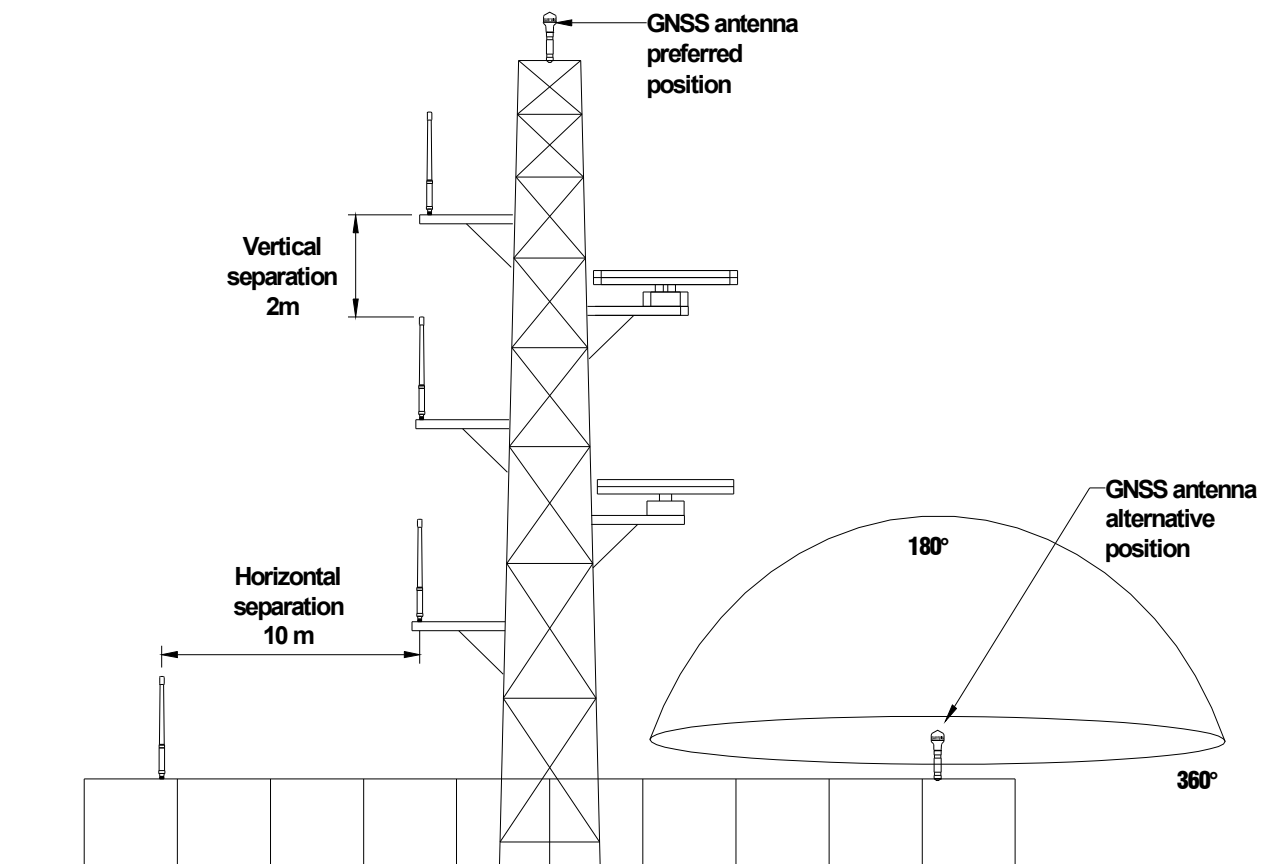

#### **4-3-2 When you install VHF Antenna, please check bellows.**

- ◆ The position of bracket.
- ◆ The bracket should be substantial spot.
- ◆ Put the antenna on Antenna's mount.
- ◆ Use RG-8U (coaxial cables) cables and keep shortened cables if possible.
- ◆ Leave some length of cables to the terminal.
- ◆ Put the connector at either ends of coaxial cables.

## 5. Maintenance and Troubleshooting

### 5-1 Maintenance and Troubleshooting of System

It is quite necessary to do periodical maintenance and troubleshooting for keeping performance of unit in good order. It means periodical unit test, and software upgraded if necessary but which following items should be included.

| ITEM                         | CONTENT  |
|------------------------------|--|
| Connector/Terminal           | Check if the connection of connector and terminal is properly connected from rear part of transponder unit and MKD unit.   |
| Cable                        | Check conditions of all cables. Replace it immediately with new one if something wrong has been founded.   |
| Ground port and Ground cable | Check condition of ground terminal. Replace it or clean cables if it is decayed or rusted. Check the connection of ground cable.   |
| Keep it clean                | The dust on unit should be cleaned by using a clear for prevent LCD from damage.<br>In case of having dot of salt or dust on the unit, it must be cleaned by cleaning tissues or cotton, but not by any chemical acid that may spoil the paint on surface of unit. |

### 5-2 Troubleshooting

The following table shows general defective symptom and solution for the defects.

Even though users cannot restore the equipment with general methods, don't even try to look into the inside of the equipment. Whatever the issue is, the equipments must be checked by technical specialists.

A/S PIC ☎ : 051-601-5570~5574

| SYMPTOMS                           | ACTIONS TO BE TAKEN   |
|------------------------------------|---|
| NO TURN ON                         | Check if power connector is fixed well.<br>Check power supply / fuse. |
| No receiving Satellite information | Check if GPS antenna, cables, connectors have defects on connection.  |

## 6. Appendix

### 6-1 NMEA sentences used

The ports on the SI-30A transponder accept and output different combinations of NMEA sentences as follows:

| Port  | Input sentences  | Output sentences   |
|---|--|--|
| Main, Display and Aux<br>("Presentation ports") | ACA, ABM, BBM, ACK, AIR,<br>AIQ, LRI, LRF, VSD, SSD              | ABK, ACA, ACS, ALR, LRI, LRF, LR1,<br>LR2, LR3, SSD, TXT, VDO,VDM, VSD |
| Long Range                                      | LRI, LRF   | LRI, LRF, LR1, LR2, LR3  |
| S1, S2, S3<br>("Sensor ports")                  | DTM, GBS, GGA, GLL, GNS,<br>HDT, RMC, ROT, VBW, VTG,<br>THS, OSD | None   |

### 6-2 Alarm Messages

The transponder may generate various alarm and information messages that appear as pop-ups on the display. Messages categorised as "alarms" also cause the transponder to generate an audible or visual alarm (depending on the installation) and must be acknowledged on the display unit in order to clear the alarm.

#### ■ Tx malfunction

This indicates that there is a problem with the transponder. The occasional occurrence of this alarm may be caused by transient conditions and does not necessarily indicate a permanent problem. However, if this alarm occurs on a regular basis you should take action to have your installation checked by an authorised service agent.

#### ■ Antenna VSWR exceeds limits

This indicates that there is a problem with the antenna. The transponder is likely to be still operational, although its performance may be impaired. The occasional occurrence of this alarm may be caused by transient conditions and does not necessarily indicate a permanent problem. However, if this alarm continues to occur you should take action to have your installation checked by an authorised service agent.

- **Rx Channel 1 malfunction**
- **Rx Channel 2 malfunction**
- **Rx Channel 70 malfunction**

These messages indicate that there is a possible problem with the receiver for AIS channel A, AIS channel B or the DSC channel 70 respectively. Again, the occasional occurrence of this message should not be cause for alarm, but the regular occurrence of these messages is likely to indicate a permanent problem which should be investigated by an authorised service agent.

#### ■ **Transceiver connection lost**

This message indicates that the SI-30A display unit can no longer communicate with the SI-30A transponder. This may indicate a problem with the connections, or may indicate that the transponder is no longer operating correctly. This fault should be investigated immediately. It is important to note that there is a safety timer in the transponder which causes it to shut down automatically if the transmitter should remain on for too long. In this event, the transponder will shut down and this alarm will be raised by the display unit. The situation can be resolved by disconnecting the power from the transponder for a short time and then re-connecting it again.

#### ■ **External EPFS lost**

This message indicates that the transponder is no longer receiving data from the vessel's on-board GPS system. This message should be investigated immediately.

#### ■ **No position sensor in use**

This message indicates that the SI-30A transponder is unable to obtain a location fix from either the internal GPS module or from the ship's own GNSS system. This message may occur during the first few minutes of operation while the transponder waits to obtain its location, and may safely be ignored during this time. If the message occurs at any other time, it indicates a possible problem with the GNSS antennae or wiring and should be investigated immediately

- **No valid SOG information**
- **No valid COG information**
- **Heading lost/invalid**
- **No valid ROT information**

These messages indicate that information from various sensors are not available. In a full installation it is expected that all this information will be available permanently and the display of one or more of these messages is an indication that there may be problems either with the other sensors or with the connections between the sensors and the SI-30A transponder unit. Such messages should be investigated immediately.

- **UTC clock lost**

This message indicates that internal GPS module within the SI-30A transponder is unable to obtain a valid time signal. If this message appears on a regular basis it may indicate a problem with the GNSS antenna connection, but it is possible for this message to occur temporarily in certain locations or in extreme weather conditions where the GNSS module is unable to receive transmissions from a sufficient number of satellites.

- **External DGNSS in use**
- **External GNSS in use**
- **Internal DGNSS in use (beacon)**
- **Internal DGNSS in use (msg 17)**
- **Internal GNSS in use**

These messages indicate which source of GNSS information is currently in use by the transponder. The external GNSS information from the ship's main onboard systems may or may not be augmented by differential correction information - in which case the messages show "DGNSS" rather than "GNSS". When the external GNSS signals are not available, the SI-30A transponder uses GNSS information from its own internal GNSS module and the message changes to "Internal GNSS". This information may be augmented by the receipt of differential correction data from a beacon receiver or by VHF transmissions from a base station - in which case the status message shows "DGNSS" and "beacon" or "msg 17" respectively to indicate the source of the differential data being used.

- **External SOG/COG in use**
- **Internal SOG/COG in use**

These messages indicate whether Speed over Ground and Course over Ground are being supplied by the external sensors or are being calculated from the internal GNSS module.

- **Heading valid**

This message is received when a valid heading is first received from the ship's sensors.

- **Rate of Turn indicator in use**
- **Other ROT source in use**

The first of these messages indicates that the SI-30A transponder is using Rate of Turn information from an on-board device which directly calculates the rate of turn - such as a gyro compass. The second message indicates that the rate of turn is being calculated from changes in the ship's heading.

- **Chan management params changed**

This message is issued each time that any of the channel management parameters are altered. These may be altered by the receipt of specific VHF or DSC messages from base stations and can also be modified directly by using the "Channel Regions" page on the SI-30A's display unit.

### 6-2-1 Decoded Sentences

The sentence types listed in the table below are decoded by the Transponder.

| Formatter | Source  | Primary function | Optional function      | Comment                  |
|-----------|---------|------------------|------------------------|--------------------------|
| ABK       | AIS     |                  |                        | VDL Ack                  |
| ABM       | AIS     |                  |                        | Addressed binary message |
| BBM       |         |                  |                        | Broadcast binary message |
| AIR       | AIS     |                  |                        | Interrogation            |
| ACA       | AIS     |                  |                        | Channel assignment       |
| ROT       | Sensor  | Rate of turn     |                        |                          |
| HDT       | Sensor  | Heading          |                        | Heading                  |
| VBW       | Sensor  | SOG              |                        |                          |
| GNS       | GNSS    | Pos+time of pos  |                        |                          |
| GLL       | GNSS    | Pos+time of pos  |                        |                          |
| RMC       | GNSS    | COG              | Pos + time of pos, SOG |                          |
| GBS       | GNSS    | RAIM indication  |                        | RAIM                     |
| VTG       | GNSS    |                  | COG, SOG               |                          |
| GGA       | GPS     |                  | Pos + time of pos      |                          |
| VSD       | Display |                  |                        | Voyage data              |
| SSD       | Display |                  |                        | Static data              |
| LRF       | LR      |                  |                        | Long range interrogation |
| LRI       | LR      |                  |                        | Long range interrogation |
| TXT       |         |                  |                        |                          |
| ALR       |         |                  |                        |                          |
| ACK       | Display |                  |                        | Alarm ack                |

### 6-2-2 Position Sensor Priority List

|                                    |                    |
|------------------------------------|--------------------|
| Priority (Highest first)           | Sources            |
| External Differential GNSS         | GNS, GLL, RMC, GGA |
| Internal Differential GNSS (msg17) | GNS, GLL, RMC, GGA |
| Internal Differential GNSS (RTCM ) | GNS, GLL, RMC, GGA |
| External GNSS                      | GNS, GLL, RMC, GGA |
| Internal GNSS                      | GNS, GLL, RMC, GGA |
| Manual input                       |                    |
| None available                     |                    |

Notes : RAIM indication requires a valid GBS message from the sensor currently in use.

## 6-3 Message structures

Message structures are shown in the format used in IEC 61162-1

### 6-3-1 ABK - AIS addressed and binary broadcast acknowledgement

The ABK sentence is output by the transponder on the presentation ports in response to the receipt of an ABM, AIR or BBM sentence. Its purpose is to inform the requesting device about the success or failure of its request.

```
$--ABK ,xxxxxxxx ,x ,x.x ,x ,x *hh<CR><LF>
```

① ② ③ ④ ⑤

- |                                   |                            |
|-----------------------------------|----------------------------|
| ①. MMSI of the addressed AIS unit | ② AIS channel of reception |
| ③ M.1371 Message ID               | ④ Message sequence number  |
| ⑤ Type of acknowledgement         |                            |

### 6-3-2 ABM – AIS addressed binary and safety related message

This sentence is used to transmit M.1371 messages 6 (binary addressed) or 12 (addressed safety related) via the AIS system by encapsulating the M.1371 message within one or more AIS sentences.

```
$--ABM ,x ,x ,x ,xxxxxxxx ,x ,xx ,s—s ,x *hh<CR><LF>
```

① ② ③ ④ ⑤ ⑥ ⑦ ⑧

- |                                 |                                    |
|---------------------------------|------------------------------------|
| ① total number of sentences     | ② sentence number                  |
| ③ sequential message identifier | ④ MMSI of the destination AIS unit |
| ⑤ AIS channel                   | ⑥ M.1371 Message ID (6 or 12)      |
| ⑦ encapsulated data             | ⑧ number of fill-bits              |

When the transponder receives an ABM sentence from an external device, it will return an ABK sentence to indicate the success or failure of the transmission attempt.

### 6-3-3 ACA – AIS channel assignment message

```
$--ACA ,x ,llll.ll,a ,yyyyy.yy,a ,llll.ll,a ,yyyyy.yy,a ,x ,xxxx ,x ,xxxx ,x ,x ,x ,a ,x ,hhmmss.ss *hh<CR><LF>
```

① ② ③ ④ ⑤ ⑥ ⑦ ⑧ ⑨ ⑩ ⑪ ⑫ ⑬ ⑭ ⑮

- |  |   |
|--|---|
| ① sequence number                        | ② region northeast corner latitude, N/S |
| ③ region northeast corner longitude, E/W | ④ region southwest corner latitude, N/S |
| ⑤ region southwest corner longitude, E/W | ⑥ transition zone size                  |
| ⑦ channel A                              | ⑧ channel A bandwidth                   |
| ⑨ channel B                              | ⑩ channel B bandwidth                   |
| ⑪ Tx/Rx mode control                     | ⑫ power level control                   |
| ⑬ information source                     | ⑭ in-use Flag                           |



### 6-3-7 ALR – Alarm condition and status

This sentence is sent by the transponder to all presentation ports order to report an alarm condition on a device. It identifies the source of the alarm, whether it has been acknowledged or not and the time at which the condition changed.

```
$--ALR ,hhmmss.ss ,xxx,A,A ,c--c *hh<CR> <LF>
```

①            ② ③④ ⑤

- ① time of condition change                      ② alarm source
- ③ alarm condition                                      ④ acknowledge state
- ⑤ descriptive text

This sentence is sent by the transponder whenever a new alarm is raised or its condition changes state. It is also sent periodically even when there are no active alarms In order to provide a positive indication of the current status of each alarm.

### 6-3-8 BBM - AIS broadcast binary message

The BBM sentence allows an external device to instruct the transponder to broadcast a block of binary data in an M.1371 binary broadcast message (type 8) or a safety related broadcast message (type 14).

```
!--BBM ,x ,x ,x ,x ,x.x,s—s ,x *hh<CR> <LF>
```

①②③④ ⑤    ⑥ ⑦

- ① total number of sentences needed to transfer message
- ② sentence number                                      ③ sequential message identifier
- ④ AIS channel for broadcast of the radio message
- ⑤ M.1371 message ID                                      ⑥ encapsulated data
- ⑦ number of fill-bits

When the transponder receives one or more BBM sentences from an external device, is deencapsulates the encoded data and re-assembles an M.1371 message of type 8 or 14 and then 34 Issue 1 AIS Installation Manual transmits it over the VDL (if possible). It then sends an ABK sentence back to the requesting device to indicate whether the transmission of the message s ucceded or failed.

### 6-3-9 DTM – Datum reference

Local geodetic datum and datum offsets from a reference datum.

```
$--DTM,ccc,a ,x.x,a,x.x,a ,x.x,ccc *hh<CR> <LF>
```

① ② ③    ④ ⑤ ⑥

- ① Local datum    ② Local datum subdivision code
- ③ Lat offset, min, N/S                                      ④ Lon offset, min, E/W

- ⑤ Altitude offset, m
- ⑥ Reference datum

Note that the only datum supported by AIS is WGS84. The DTM sentence must be sent to the transponder at a frequency of more than once every 30 seconds otherwise any positional information sentences (eg GLL, GNS, RMC and GGA) will be ignored.

### 6-3-10 GBS – GNS satellite fault detection

This message is used to support receiver autonomous integrity monitoring (RAIM).

\$--GBS ,hhmmss.ss ,x.x,x.x,x.x ,xx ,x.x ,x.x ,x.x ,\*hh<CR><LF>

- ①
- ②
- ③
- ④
- ⑤
- ⑥
- ⑦
- ⑧

- ① UTC time of GGA or GNS fix associated with this sentence
- ② Expected error in attitude
- ③ Expected error in longitude
- ④ Expected error in altitude
- ⑤ ID number of most likely failed satellite
- ⑥ Probability of missed detection for most likely failed satellite
- ⑦ Estimate of bias on most likely failed satellite
- ⑧ Standard deviation of bias estimate

### 6-3-11 GGA – Global positioning system (GPS) fix data

Time, position and fix-related data for a GPS receiver.

\$--GGA ,hhmmss.ss ,lll.l,a ,yyyy.yy,a ,x ,xx ,x.x ,x.x ,M ,x.x ,M ,x.x,xxxx \*hh<CR><LF>

- ①
- ②
- ③
- ④
- ⑤
- ⑥
- ⑦
- ⑧
- ⑨
- ⑩
- ⑪
- ⑫

- ① UTC of position
- ② Latitude N/S
- ③ Longitude E/W
- ④ GPS quality indicator
- ⑤ Number of satellites in use
- ⑥ Horizontal dilution of precision
- ⑦ Antenna altitude above/below mean sea level (geoid)
- ⑧ Units of antenna altitude, m
- ⑨ Geoidal separation
- ⑩ Units of geoidal separation, m
- ⑪ Age of differential GPS data
- ⑫ Differential reference station ID

### 6-3-12 GLL – geographic position

This sentence is a primary source of position information for the transponder when connected to a functional GNSS system. In the absence of GNS sentences, longitude and latitude information may also be obtained from GNS, GGA or RMC sentences.

\$--GLL ,lll.l,a ,yyyy.yy,a ,hhmmss.ss ,A ,a \*hh<CR><LF>

- ①
- ②
- ③
- ④
- ⑤

- ① latitude, N/S
- ② longitude, E/W
- ③ UTC of position
- ④ status ('A' -> use mode flag; 'V' -> use position as default)
- ⑤ mode indicator ('A', 'D', 'E', 'M' -> used; 'N' -> invalid)

Note that DTM sentences must be received by the transponder at least once every 30 seconds in order for the GLL sentence to be accepted.

### 6-3-13 GNS – GNSS fix data

The transponder may receive this sentence from other sensors and uses the information in its own calculations of the ship's current position.

```
$--GNS ,hhmmss.ss ,llll.ll,a ,yyyy.yy,a ,c—c ,xx ,x.x ,x.x ,x.x ,x.x ,x.x *hh<CR><LF>
```

- |   |                                       |
|---|---------------------------------------|
| ① UTC of position   | ② latitude, N/S                       |
| ③ longitude, E/W  |                                       |
| ④ mode indicator ('A', 'D', 'E', 'M' - used; 'N' - default value) |                                       |
| ⑤ number of satellites in use (ignored)                           | ⑥ HDOP (ignored)                      |
| ⑦ antenna altitude (ignored)                                      | ⑧ geoidal separation (ignored)        |
| ⑨ age of diff data (ignored)                                      | ⑩ Diff reference station ID (ignored) |

### 6-3-14 HDT – heading true

This sentence provides the actual vessel heading and may be sent by any system or device that calculates true headings.

```
$--HDT ,x.x,T *hh<CR><LF>
```

- ① heading, degrees true

### 6-3-15 LR1 - AIS long-range reply 1

The LR1 sentence identifies the destination for the reply and contains the information items requested by the function identification character in the LRF sentence that requested the information.

```
$--LR1 ,x ,xxxxxxxx ,xxxxxxxx ,c—c ,c—c ,xxxxxxxx *hh<CR><LF>
```

- |   |                     |
|---|---------------------|
| ① sequence number                       | ② MMSI of responder |
| ③ MMSI of requestor (reply destination) | ④ ship's name       |
| ⑤ call sign                             | ⑥ IMO number        |

### 6-3-16 LR2 - AIS long-range reply 2

The LR2 sentence contains further information items that can be requested in an LRF sentence.

```
$--LR2 ,x ,xxxxxxxx ,xxxxxxxx ,hhmmss.ss ,llll.ll,a ,yyyy.yy,a ,x.x,T ,x.x,N *hh<CR><LF>
```

- |   |   |   |   |   |   |   |   |
|---|---|---|---|---|---|---|---|
| ① | ② | ③ | ④ | ⑤ | ⑥ | ⑦ | ⑧ |
|---|---|---|---|---|---|---|---|

- |                   |  |
|-------------------|--|
| ① sequence number | ② MMSI of responder                                |
| ③ date            | ④ UTC time of position                             |
| ⑤ latitude, N/S   | ⑥ longitude, E/W                                   |
| ⑦ True            | ⑧ speed over ground, Knots course over ground, deg |

### 6-3-17 LR3 - AIS long-range reply 3

The LR3 sentence contains further information items that can be requested in an LRF sentence.

\$--LR3 ,x,xxxxxxxx,c—c,xxxxxx ,hhmmss.ss ,x.x ,x.x ,x.x ,x.x ,x.x \*hh<CR><LF>

① ② ③ ④ ⑤ ⑥ ⑦ ⑧ ⑨ ⑩ ⑪

- |                   |                     |                      |
|-------------------|---------------------|----------------------|
| ① sequence number | ② MMSI of responder | ③ voyage destination |
| ④ ETA date        | ⑤ ETA time          | ⑥ draught            |
| ⑦ ship/cargo      | ⑧ ship length       | ⑨ ship breadth       |
| ⑩ ship type       | ⑪ persons           |                      |

### 6-3-18 LRF - AIS long-range function

This sentence is used in both long-range interrogation requests and long-range interrogation replies. The LRF-sentence is the second sentence of the long-range interrogation request pair LRI and LRF. The LRF sentence is also the first sentence of the long-range interrogation reply. The minimum reply consists of an LRF sentence followed by a LR1 sentence. The LR2 sentence and/or the LR3 sentences follow the LR1 sentence if information provided in these sentences was requested by the interrogation.

\$--LRF ,x,xxxxxxxx,c—c,c—c,c—c \*hh<CR><LF>

① ② ③ ④ ⑤

- |                    |                         |                     |
|--------------------|-------------------------|---------------------|
| ① sequence number  | ② MMSI of requestor     | ③ name of requestor |
| ④ function request | ⑤ function reply status |                     |

### 6-3-19 LRI - AIS long-range interrogation

Long-range interrogation is a mechanism that allows one AIS unit to request certain data from another AIS unit through the use of a number of interrogation and reply sentences. When the transponder receives an LRI and LRF sentence pair on its Long Range port, it forwards them on to all the presentation ports. If the transponder has been configured to provide an automatic response to the interrogation then it does so; otherwise it waits for the sentences to be returned to it (on any presentation port) before responding.

\$--LRI ,x ,a ,xxxxxxxx,xxxxxxxx ,llll.ll ,a ,yyyyy.yy ,a ,llll.ll ,a ,yyyyy.yy ,a \*hh<CR><LF>

①② ③ ④ ⑤ ⑥ ⑦ ⑧

- |                                  |                                   |
|----------------------------------|-----------------------------------|
| ① sequence number                | ② control flag                    |
| ③ MMSI of requestor              | ④ MMSI of destination             |
| ⑤ latitude, N/S (NE co-ordinate) | ⑥ longitude, E/W (NE co-ordinate) |
| ⑦ latitude, N/S (SW coordinate)  | ⑧ longitude, E/W (SW coordinate)  |

### 6-3-20 OSD – Own ship data

Heading, course, speed, set and drift summary. Useful for, but not limited to radar/ARPA applications. OSD gives the movement vector of the ship based on the sensors and parameters in use.

\$--OSD, x.x,A,x.x,a,x.x,a,x.x,x.x,a\*hh<CR><LF>

① ② ③ ④ ⑤ ⑥ ⑦ ⑧ ⑨

- |   |  |
|---|--|
| ① Heading, degrees true                                 | ② Heading status: A = data valid, V = data invalid |
| ③ Vessel course, degrees true                           | ④ Course reference, B/M/W/R/P (see Note)           |
| ⑤ Vessel speed  | ⑥ Speed reference, B/M/W/R/P (see Note)            |
| ⑦ Vessel set, degrees true                              | ⑧ Vessel drift (speed)                             |
| ⑨ Speed units, K = km/h; N = knots; S = statute miles/h |  |

NOTE Reference systems on which the calculation of vessel course and speed is based. The values of course and speed are derived directly from the referenced system and do not additionally include the effects of data in the set and drift fields.

B = bottom tracking log

M = manually entered

W = water referenced

R = radar tracking (of fixed target)

P = positioning system ground reference.

### 6-3-21 RMC – recommended minimum specific GNSS data

This sentence is used to transmit the time, data, position, course and speed data from a GNSS navigation receiver. The sentence is transmitted at least once every two seconds from GNSS device(s) and is always accompanied by an RMB sentence when a destination waypoint is active.

\$--RMC, hhmmss.ss ,A, llll.ll, a, yyyyyy.yy, a ,x.x ,x.x ,xxxxxx,x.x,a ,a \*hh<CR><LF>

① ② ③ ④ ⑤ ⑥ ⑦ ⑧ ⑨

- |   |                      |
|---|----------------------|
| ① UTC of position fix   |                      |
| ② status ('A' -> use mode field; 'V' -> use fields as default values) |                      |
| ③ latitude, N/S   | ④ longitude, E/W     |
| ⑤ speed over ground   | ⑥ course over ground |

- ⑦ date
- ⑧ magnetic variation
- ⑨ mode indicator ('A', 'D', 'E', 'M' -> used; 'N' -> invalid)

Note that RMC has priority over VTG.

### 6-3-22 ROT – rate of turn

This sentence provides the rate and direction of turn.

```
$--ROT ,x.x,A*hh<CR><LF>
```

- ① ②

- ① rate of turn
- ② status ('A' -> rate of turn is valid)

### 6-3-23 SSD – Ship Static Data

This sentence is used to enter static parameters into a shipboard AIS. The parameters in this sentence support a number of the ITU-R M.1371 messages.

```
$--SSD,c--c,c--c,xxx,xxx,xx,xx,c,aa*hh<CR><LF>
```

- ① ② ③ ④ ⑤ ⑥ ⑦ ⑧

- ① Ship's Call Sign, 1 to 7 characters
- ② Ship's Name, 1 to 20 characters
- ③ Pos. ref., "A," distance from bow, 0 to 511 metres
- ④ Pos. ref., "B," distance from stern, 0 to 511 metres
- ⑤ Pos. ref., "C," distance from port beam, 0 to 63 metres
- ⑥ Pos. ref., "D," distance from starboard beam, 0 to 63 metres
- ⑦ DTE indicator flag
- ⑧ Source identifier

### 6-3-24 THS – True heading and status

Actual vessel heading in degrees true produced by any device or system producing true heading. This sentence includes a "mode indicator" field providing critical safety related information about the heading data, and replaces the deprecated HDT sentence.

```
$--THS,x.x,a*hh<CR><LF>
```

- ① ②

- ① Heading, degrees true
- ② Mode indicator (see Note)

NOTE Mode indicator. This field should not be null.

A = Autonomous

E = Estimated (dead reckoning)

M = Manual input

S = Simulator mode

V = Data not valid (including standby)

### 6-3-25 TXT – text transmission

This sentence is used for transmitting text messages such as alarm messages from a sensor or the transponder to any presentation display device such as the SI-30A Display unit.

\$--TXT ,xx ,xx ,xx ,c--c \*hh<CR><LF>

① ② ③ ④

- ① total number of messages                      ② message number
- ③ text identifier                                      ④ text message

### 6-3-26 VBW – Dual ground/water speed

S—VBW,x.x,x.x,A,x.x,x.x,A,x.x,A,x.x,A \*hh<CR><LF>

① ② ③ ④ ⑤ ⑥ ⑦ ⑧ ⑨ ⑩

- ① Longitudinal water speed                      ② Traverse water speed
  - ③ Status: water speed                              ④ Longitudinal ground speed
  - ⑤ Traverse ground speed                          ⑥ Status: ground speed
  - ⑦ Stern traverse water speed                      ⑧ Status: stern water speed
  - ⑨ Stern traverse ground speed                      ⑩ Status: stern ground speed
- Longitudinal ground speed – used              Transverse ground speed – used  
 Status of ground speed – used                  Other fields ignored

### 6-3-27 VDM – VHF data link message

This sentence is output by the transponder each time it receives an incoming message over the VHF data link. The VDM sentence encapsulates a part of an M.1371 message, and several VDM sentences may need to be decoded and re-assembled in order to re-construct the original M.1371 message.

!--VDM ,x ,x ,x ,a ,s—s ,x \*hh<CR><LF>

① ② ③ ④ ⑤ ⑥

- ① total number of sentences needed to transfer message
- ② sentence number                                      ③ sequential message identifier
- ④ AIS Channel    ⑤ encapsulated ITU-R M.1371 radio message
- ⑥ number of fill-bits

### 6-3-28 VDO - AIS VHF Data-link own-vessel report

This sentence is output to all the presentation ports at regular intervals and contains the contents of the transponders own-vessel report. Each time the transponder transmits an own-vessel report, it encapsulates the M.1371 message in one or more VDO sentences and outputs them on its presentation ports.

!-VDO ,x ,x ,x ,a ,s—s ,x \*hh<CR><LF>

① ② ③ ④ ⑤ ⑥

- ① total number of sentences needed to transfer message
- ② sentence number
- ③ sequential message identifier
- ④ AIS Channel ('A' or 'B')
- ⑤ encapsulated ITU-R M.1371 radio message
- ⑥ number of fill-bits

The transponder outputs one VDO sentence every second in addition to echoing all transmitted VDO sentences as they are transmitted in order to provide frequent updates to all connected presentation devices. VDO sentences which have also been transmitted contain the appropriate AIS channel indicator whereas VDO sentences that have not been transmitted contain a NULL field for the channel indicator.

### 6-3-29 VSD – AIS voyage static data

This sentence may be output by the transponder in response to a query.

\$--VSD ,x.x ,x.x ,x.x ,c—c ,hhmmss.ss ,xx ,xx ,x.x ,x.x \*hh<CR><LF>

① ② ③ ④ ⑤ ⑥ ⑦ ⑧ ⑨

- ① type of ship and cargo category
- ② maximum present static draught
- ③ persons on-board
- ④ destination
- ⑤ estimated UTC of arrival at destination
- ⑥ estimated day of arrival at destination
- ⑦ estimated month of arrival at destination
- ⑧ navigational status
- ⑨ regional application flags

### 6-3-30 VTG – course over ground and ground speed

This sentence contains the actual course and speed relative to the ground.

\$--VTG ,x.x,T ,x.x,M ,x.x,N ,x.x,K,a \*hh<CR><LF>

① ② ③ ④ ⑤

- ① course over ground, degrees true
- ② course over ground, degrees magnetic (ignored)
- ③ speed over ground, knots
- ④ speed over ground, km/h (ignored)
- ⑤ mode indicator





Note that RMC has priority over VTG.

## 6-4 Abbreviations

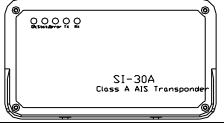
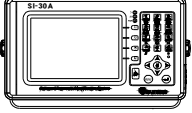
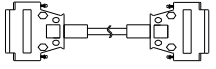

|       |  |          |   |
|-------|--|----------|---|
| 4S    | : Ship-to-Ship & Ship-to-Shore   | AIS      | : Automatic Identification System             |
| ALM   | : Alarm  | ANT      | : Antenna                                     |
| ARPA  | : Automatic Radar Plotting Aid   | ATA      | : Automatic Tracking Aid                      |
| AtoN  | : Aid to Navigation  | AUX      | : Auxiliary                                   |
| AUTO  | : Automatic  | BI IT    | : Built-In Integrity Test                     |
| BAT   | : Battery  | BRILL    | : Display Brilliance                          |
| BRG   | : Bearing  | CG       | : Coast Guard                                 |
| CH    | : Channel  | CHG      | : Change                                      |
| CLR   | : Clear  | CNCL     | : Cancel                                      |
| CNS   | : Communication, Navigation & Surveillance                             | COG      | : Course Over Ground                          |
| CONTR | : Contrast   | CPA      | : Closest Point of Approach                   |
| CPU   | : Central Processing Unit  | CSE      | : Course                                      |
| DEL   | : Delete   | DEST     | : Destination                                 |
| DG    | : Dangerous Goods  | DGLONASS | : Differential GLONASS                        |
| DGNSS | : Differential GNSS  | DGPS     | : Differential GPS                            |
| DISP  | : Display  | DIST     | : Distance                                    |
| DSC   | : Digital Selective Calling  | DTE      | : Data Terminal Equipment                     |
| ECDIS | : Electronic Chart Display and Information System                      | ECS      | : Electronic Chart System                     |
| EGNOS | : European Geo-stationary Navigational Overlay System                  | ENC      | : Electronic Navigation Chart                 |
| ENT   | : Enter  | EPA      | : Electronic Plotting Aid                     |
| EPFS  | : Electronic Position Fixing System                                    | EPIRB    | : Electronic Position Indicating Radio Beacon |
| ERR   | : Error  | ETA      | : Estimated Time of Arrival                   |
| EXT   | : External   | FCC      | : Federal Communications Commission           |
| FREQ  | : Frequency  | GLO or   | : Global Orbiting Navigation Satellite System |
| GMDSS | : Global Maritime Distress and Safety System                           | GLONASS  |   |
| GNSS  | : Global Navigation Satellite System                                   | GND      | : Ground                                      |
| GYRO  | : Gyro Compass   | GPS      | : Global Positioning System                   |
| HS    | : Hazardous Substances   | HDG      | : Heading                                     |
| I/O   | : Input / Output   | HSC      | : High Speed Craft                            |
| ID    | : Identification   | IBS      | : Integrated Bridge System                    |
| IMO   | : International Maritime Organisation                                  | IEC      | : International Electrotechnical Commission   |
| INFO  | : Information  | IN       | : Input                                       |
| ITU-R | : International Telecommunications Union – Radiocommunications Bureaux | INS      | : Integrated Navigation System                |
| L/L   | : Latitude / Longitude   | KN       | : Knots                                       |
| LOST  | : TGT Lost Target  | LAT      | : Latitude                                    |
| MAG   | : Magnetic   | LON      | : Longitude                                   |
| MED   | : Marine Equipment Directive   | M        | : Metres                                      |
| MID   | : Maritime Identification Digit  | MAN      | : Manual                                      |
| MKD   | : Minimum Keyboard and Display   | MF/HF    | : Medium Frequency/High Frequency             |
| MOB   | : Man Overboard  | MIN      | : Minimum                                     |
|       |  | MMSI     | : Maritime Mobile Service Identity            |
|       |  | MP       | : Marine Pollutant                            |



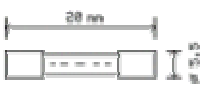

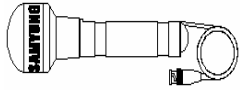

|       |  |      |  |
|-------|--|------|--|
| NAV   | : Navigation                               | NM   | : Nautical Mile                                    |
| NUC   | : Not Under Command                        | OOW  | : Officer Of the Watch                             |
| OS    | : Own Ship                                 | OUT  | : Output   |
| PI    | : Presentation Interface                   | POSN | : Position   |
| PPU   | : Portable Pilot Unit                      | PWR  | : Power  |
| RAIM  | : Receiver Autonomous Integrity Monitoring | RNG  | : Range  |
| RORO  | : Roll On, Roll Off                        | ROT  | : Rate Of Turn                                     |
| RR    | : Range Rings                              | RTCM | : Radio Technical Commission for Maritime services |
| RTE   | : Route                                    | Rx   | : Receive / Receiver                               |
| SAR   | : Search And Rescue                        | SEL  | : Select   |
| SOG   | : Speed Over Ground                        | SPD  | : Speed  |
| SPEC  | : Specification                            | STBD | : Starboard  |
| STBY  | : Standby                                  | STW  | : Speed Through Water                              |
| TCPA  | : Time to Closest Point of Approach        | TDMA | : Time Division Multiple Access                    |
| TGT   | : Target                                   | TPR  | : Transponder                                      |
| TRK   | : Track                                    | TSS  | : Traffic Separation Scheme                        |
| TTG   | : Time To Go                               | Tx   | : Transmit / Transmitter                           |
| Tx/Rx | : Transceiver                              | UAIS | : Universal Automatic Identification System        |
| UHF   | : Ultra High Frequency                     | UTC  | : Universal Time Co-ordinate                       |
| MKD   | : Visual Display Unit                      | VHF  | : Very High Frequency                              |
| VOY   | : Voyage                                   | VSWR | : Virtual Standing Wave Ratio                      |
| VTS   | : Vessel Traffic Systems                   | WAAS | : Wide Area Augmentation System                    |
| WCV   | : Waypoint Closure Velocity                | WGS  | : World Geodetic System                            |
| WIG   | : Wing In Ground                           | WPT  | : Waypoint   |

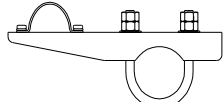
## 6-5 PACKING LIST

| SI-30A |             |   |                        |             |      |      |                |
|--------|-------------|---|------------------------|-------------|------|------|----------------|
| NO.    | Item        | External Feature  | Standard               |             | Q'ty | CHK  | Remark         |
| 1      | Transponder |    | SI-30A                 |             | 1    |      |                |
|        |             |   | CODE NO.               | E02-3000-00 |      |      |                |
| 2      | MKD         |    | SI-30AM                |             | 1    |      |                |
|        |             |   | CODE NO.               | E02-4000-01 |      |      |                |
| 3      | Cable Ass'y |    | DSUB25-7M-DSUB25       |             | 1    | A-03 | OPT. 10M       |
|        |             |   | CODE NO.               | 574-0166-01 |      |      |                |
| 4      | Cable Ass'y |    | SCN3-3M-02 Cable Ass'y |             | 1    | A-05 | DC             |
|        |             |   | CODE NO.               | 574-0390-01 |      |      |                |
| 5      | Screw       |    | Stain Truss Piece 4X16 |             | 10   |      | Packing        |
|        |             |   | CODE NO.               | 904-0446-01 |      |      |                |
| 6      | Cable Ass'y |  | 01-3M-D01 Cable Ass'y  |             | 2    | A-04 | 5.5SQ<br>OTYPE |
|        |             |   | CODE NO.               | 574-0102-01 |      |      |                |
| 7      | Cable Tie   |  | DACT300-2.5            |             | 10   |      |                |
|        |             |   | CODE NO.               | 597-0050-1D |      |      |                |
| 8      | FUSE        |  | 7A/250V[20mmX5mm]      |             | 2    |      |                |
|        |             |   | CODE NO.               | 527-2007-1Q |      |      |                |
| 9      | Manual      |   | SI-30A-ME              |             | 1    |      |                |
|        |             |   | CODE NO.               | M03-0101-00 |      |      |                |

| SAN-60 GPS Antenna |               |   |                     |             |      |      |                     |
|--------------------|---------------|---|---------------------|-------------|------|------|---------------------|
| NO.                | Item          | External Feature  | Standard            |             | Q'ty | CHK  | Remark              |
| 1                  | Antenna Ass'y |  | SAN60-30M(RG58)-TNC |             | 1    | A-02 | STAIN<br>BAND<br>X2 |
|                    |               |   | CODE NO             | 574-9999-02 |      |      |                     |

| SAN-150 VHF Antenna |               |   |                      |             |      |      |        |
|---------------------|---------------|---|----------------------|-------------|------|------|--------|
| NO.                 | Item          | External Feature  | Standard             |             | Q'ty | CHK  | Remark |
| 1                   | VHF Antenna   |  | SAN-150              |             | 1    |      |        |
|                     |               |   | CODE NO.             | 542-1400-0D |      |      |        |
| 2                   | Cable Ass'y   |  | PL259-30M(RG8)-PL259 |             | 1    | A-01 |        |
|                     |               |   | CODE NO.             | 574-0155-24 |      |      |        |
| 3                   | Bracket Ass'y |  | Bracket 35 Ass'y     |             | 1    |      |        |
|                     |               |   | CODE NO.             | 575-0006-01 |      |      |        |

| SP-700 POWER SUPPLY UNIT |                   |   |                        |             |      |      |                |
|--------------------------|-------------------|---|------------------------|-------------|------|------|----------------|
| NO.                      | Item              | External Feature  | Standard               |             | Q'ty | CHK  | Remark         |
| 1                        | Power supply unit |    | SP-700                 |             | 1    |      |                |
|                          |                   |   | CODE NO.               | V01-0000-00 |      |      |                |
| 2                        | Cable Ass'y       |  | SCN2-3M-02 Cable Ass'y |             | 1    | B-01 | AC             |
|                          |                   |   | CODE NO.               | 574-0107-01 |      |      |                |
| 3                        | Cable Ass'y       |  | 03-3M-C3 Cable Ass'y   |             | 1    | B-02 | DC             |
|                          |                   |   | CODE NO.               | 574-0307-01 |      |      |                |
| 4                        | Fuse              |  | 5A/250V[20mmX5mm]      |             | 2    |      | AC             |
|                          |                   |   | CODE NO.               | 527-2005-1Q |      |      |                |
| 5                        | Fuse              |  | 10A/250V[20mmX5mm]     |             | 2    |      | DC             |
|                          |                   |   | CODE NO.               | 527-2010-1Q |      |      |                |
| 6                        | Cable Ass'y       |  | 01-3M-D01 Cable Ass'y  |             | 1    | B-03 | 5.5SQ<br>OTYPE |
|                          |                   |   | CODE NO.               | 574-0102-01 |      |      |                |
| 7                        | Screw             |  | Stain Truss Piece 4X16 |             | 4    |      |                |
|                          |                   |   | CODE NO.               | 904-0446-01 |      |      |                |

| SI-30A OPTION GYRO CONVERTER |                |   |          |          |      |     |        |
|------------------------------|----------------|---|----------|----------|------|-----|--------|
| NO.                          | Item           | External Feature  | Standard |          | Q'ty | CHK | Remark |
| 1                            | GYRO CONVERTER |  | SAD-30DC |          | 1    |     | Option |
|                              |                |   | CODE NO. | SIS-5-26 |      |     |        |







**6-6-4 SI-30AM OUTLINE DRAWING**

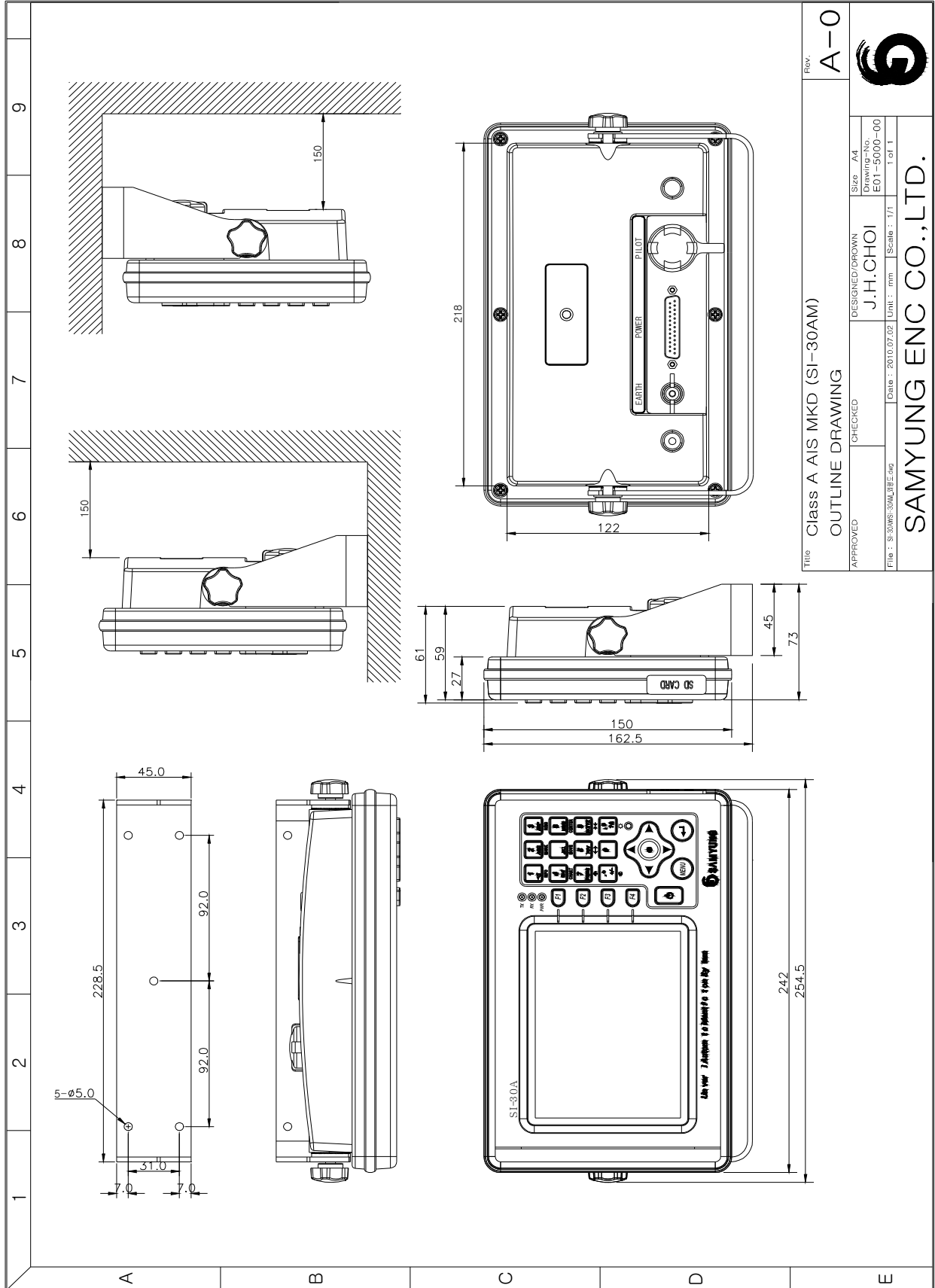

**6-6-5 SAN-150 ANTENNA OUTLINE DRAWING**

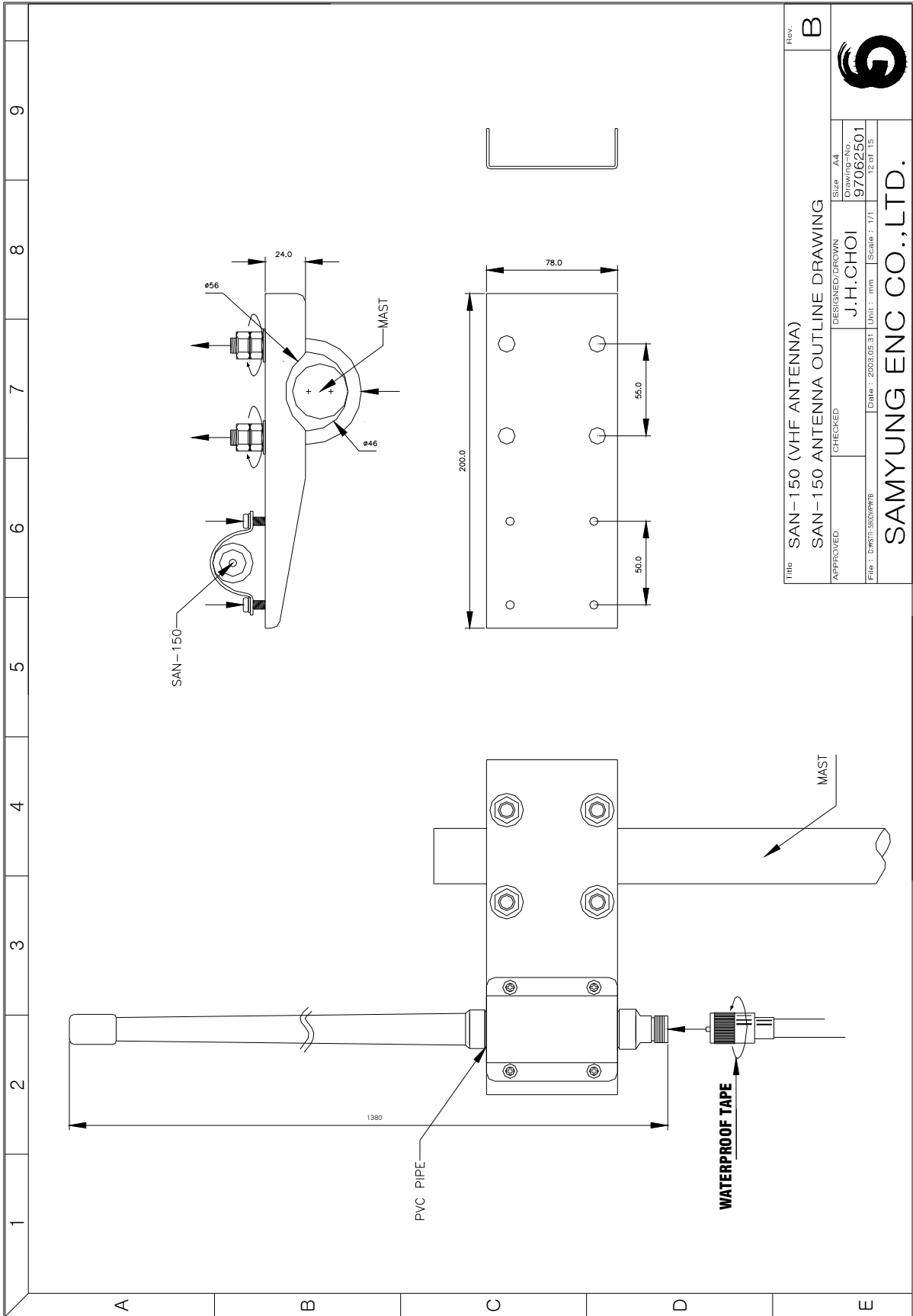

|                                 |  |                       |                |                       |          |
|---------------------------------|--|-----------------------|----------------|-----------------------|----------|
| Title                           |  | SAN-150 (VHF ANTENNA) |                | Rev.                  | B        |
| APPROVED                        |  | CHECKED               | DESIGNED/DRAWN | Size                  | A4       |
| File : 6-wk1-2003PWB            |  | Date : 2003.05.31     | Unit : mm      | Scale : 1/1           | 12 of 15 |
| DRAWN BY                        |  | J.H. CHOI             |                | DRAWING NO.           |          |
| SAN-150 ANTENNA OUTLINE DRAWING |  | 97062501              |                | SAMYUNG ENC CO., LTD. |          |



6-6-6 SAN-60 ANTENNA OUTLINE DRAWING

